

A background image of a microchip die, showing a grid of circuitry in shades of blue and green.

# Marvell<sup>®</sup> Alaska<sup>®</sup> 88E2010/88E2040L

Single and Quad 10/100/1000/2.5G/5GBASE-T Ethernet Transceiver  
**Datasheet - Public**

THIS DOCUMENT AND THE INFORMATION FURNISHED IN THIS DOCUMENT ARE PROVIDED "AS IS" WITHOUT ANY WARRANTY. MARVELL AND ITS AFFILIATES EXPRESSLY DISCLAIM AND MAKE NO WARRANTIES OR GUARANTEES, WHETHER EXPRESS, ORAL, IMPLIED, STATUTORY, ARISING BY OPERATION OF LAW, OR AS A RESULT OF USAGE OF TRADE, COURSE OF DEALING, OR COURSE OF PERFORMANCE, INCLUDING THE IMPLIED WARRANTIES OF MERCHANTABILITY, FITNESS FOR A PARTICULAR PURPOSE AND NON-INFRINGEMENT.

This document, including any software or firmware referenced in this document, is owned by Marvell or Marvell's licensors, and is protected by intellectual property laws. No license, express or implied, to any Marvell intellectual property rights is granted by this document. The information furnished in this document is provided for reference purposes only for use with Marvell products. It is the user's own responsibility to design or build products with this information. Marvell products are not authorized for use as critical components in medical devices, military systems, life or critical support devices, or related systems. Marvell is not liable, in whole or in part, and the user will indemnify and hold Marvell harmless for any claim, damage, or other liability related to any such use of Marvell products.

Marvell assumes no responsibility for the consequences of use of such information or for any infringement of patents or other rights of third parties that may result from its use. You may not use or facilitate the use of this document in connection with any infringement or other legal analysis concerning the Marvell products disclosed herein. Marvell and the Marvell logo are registered trademarks of Marvell or its affiliates. Please visit [www.marvell.com](http://www.marvell.com) for a complete list of Marvell trademarks and guidelines for use of such trademarks. Other names and brands may be claimed as the property of others.

**Copyright**

Copyright © 2020. Marvell and/or its affiliates. All rights reserved.

## PRODUCT OVERVIEW

---

The Marvell® Alaska® M 88E2010/88E2040L is a family of fully IEEE 802.3bz-compliant 1-port (88E2010) or 4-port (88E2040L) physical layer (PHY) devices. The devices support a wide variety of host-side interfaces including 5GBASE-R, 2500BASE-X, and SGMII to support full backward-compatibility with lower speed legacy Ethernet rates including: 1 Gbps, 100 Mbps, and 10 Mbps.

The flexibility of this device family enables extremely low power across all structured wiring cable lengths, enabling dense 5 Gbps applications. The device supports Category 6-type (screened or unshielded), Category 6A-type (Augmented), Category 7-type cables, and Category 5e-type cables for distances up to 100 meters.

## Features

- 1- or 4-port, five-speed PHY. Operates at 10M, 100M, 1G, 2.5G, or 5G data rates on UTP copper lines.
- Compliant with IEEE 802.3bz specifications for 2.5G and 5G modes
- 5GBASE-R, 2500BASE-X, and SGMII system-side interfaces on all devices
- Allows dense multi-port 2.5G/5G applications
- BER better than 1E-15
- 100m reach on CAT 5e for 2.5G and 5G modes
- Clause 45 MDC/MDIO management interface
- Small 10 mm × 12 mm HFCBGA package for 88E2010 single-port applications;  
23 mm × 23 mm HFCBGA package for 88E2040L quad-port applications
- Available in commercial and industrial grades



Figure 1: 88E2010 Top-level Block Diagram

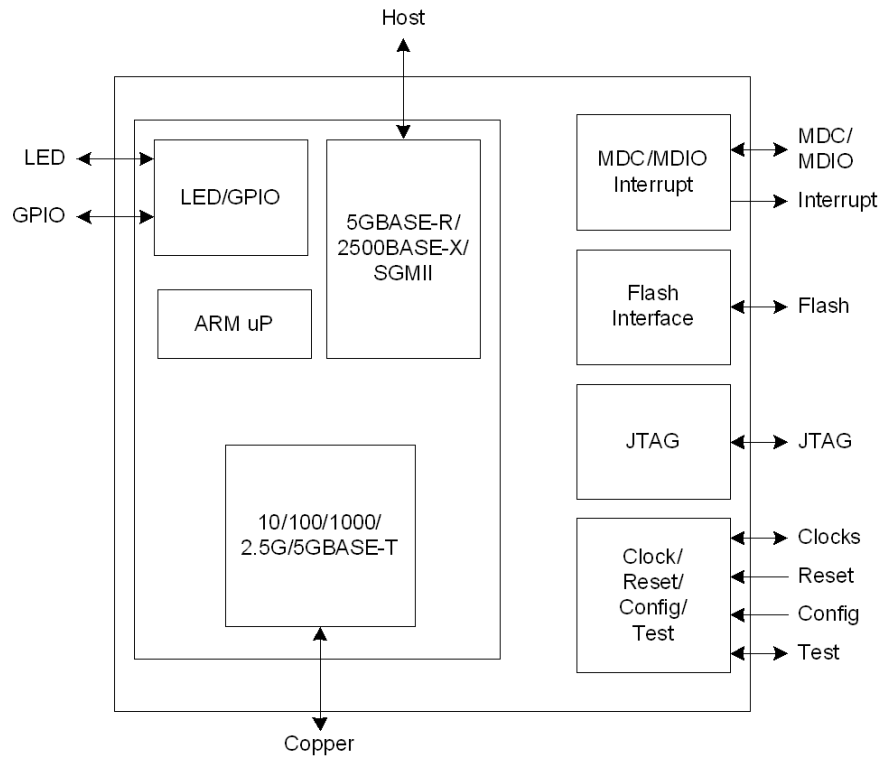
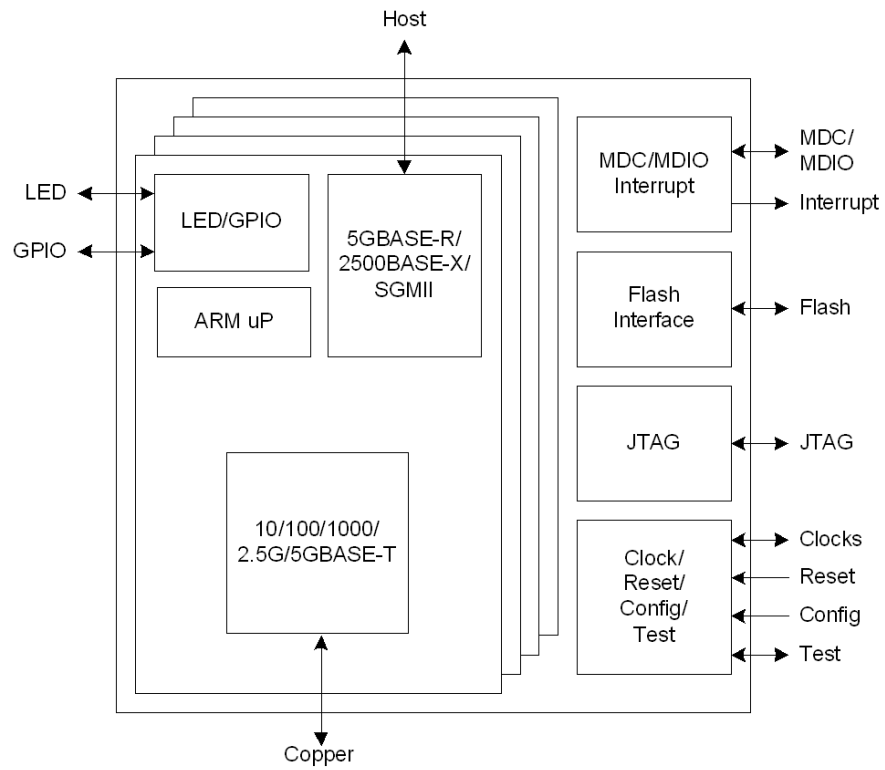

Figure 2: 88E2040L Top-level Block Diagram





# Table of Contents

- 1 General Chip Description..... 13**
- 2 Signal Description ..... 17**
  - 2.1 Pin Maps ..... 18
    - 2.1.1 88E2010 Device Pin Map ..... 18
    - 2.1.2 88E2040L Device Pin Map ..... 19
  - 2.2 Pin Description ..... 21
  - 2.3 Pin Assignment Lists..... 39
    - 2.3.1 88E2010 Device Pin Assignment List..... 39
    - 2.3.2 88E2040L Device Pin Assignment List..... 45
- 3 Functional Description ..... 62**
  - 3.1 Buffering..... 62
    - 3.1.1 EEE Buffering ..... 62
  - 3.2 Link Interrupt ..... 62
  - 3.3 Loopback ..... 63
    - 3.3.1 MAC Loopback ..... 64
    - 3.3.2 Line Loopback ..... 65
  - 3.4 Configuration and Resets..... 65
    - 3.4.1 Hardware and Software Resets..... 65
    - 3.4.2 Hardware Configuration..... 65
    - 3.4.3 Reference Clock Selection ..... 70
  - 3.5 MDC/MDIO Register Access..... 71
    - 3.5.1 Clause 45 MDIO Framing ..... 72
    - 3.5.2 30 MHz High-Speed MDC/MDIO Management Interface Protocol..... 72
    - 3.5.3 Independent MDC/MDIO Support..... 72
  - 3.6 Firmware Loading ..... 73
    - 3.6.1 Flash Memory Interface..... 73
    - 3.6.2 Firmware Download to RAM..... 73
  - 3.7 Power Management..... 73
    - 3.7.1 Manual Power Down..... 73
    - 3.7.2 MAC Interface Power Down ..... 74
    - 3.7.3 Controlling and Sensing..... 74
  - 3.8 LED ..... 74
    - 3.8.1 LED Polarity..... 74
    - 3.8.2 Pulse Stretching and Blinking ..... 75
    - 3.8.3 Bi-Color LED Mixing ..... 75
    - 3.8.4 Modes of Operation ..... 76
    - 3.8.5 Speed Blink..... 77
    - 3.8.6 Combo LED Modes ..... 78
  - 3.9 Interrupt..... 81
  - 3.10 IEEE 1149.1 and 1149.6 Controller ..... 82
    - 3.10.1 BYPASS Instruction..... 82
    - 3.10.2 SAMPLE/PRELOAD Instruction ..... 83
    - 3.10.3 EXTEST Instruction ..... 93
    - 3.10.4 CLAMP Instruction..... 93
    - 3.10.5 HIGH-Z Instruction..... 93

|          |   |            |
|----------|---|------------|
| 3.10.6   | ID CODE Instruction .....                         | 93         |
| 3.10.7   | EXTEST_PULSE Instruction .....                    | 93         |
| 3.10.8   | PROG_HYST Instruction .....                       | 94         |
| 3.10.9   | AC-JTAG Fault Detection .....                     | 94         |
| 3.11     | Reference Clock.....                              | 98         |
| 3.12     | Power Supplies .....                              | 99         |
| 3.12.1   | AVDDL.....  | 99         |
| 3.12.2   | AVDDH.....  | 99         |
| 3.12.3   | AVDDT.....  | 99         |
| 3.12.4   | AVDDC.....  | 99         |
| 3.12.5   | AVDDS.....  | 99         |
| 3.12.6   | AVDDR.....  | 99         |
| 3.12.7   | DVDD.....   | 99         |
| 3.12.8   | VDDO.....   | 99         |
| 3.12.9   | VHV.....  | 100        |
| 3.12.10  | VDD09.....  | 100        |
| <b>4</b> | <b>Copper Unit (T Unit).....</b>                  | <b>101</b> |
| 4.1      | Media Interface .....                             | 101        |
| 4.1.1    | 2.5GBASE-T and 5GBASE-T .....                     | 101        |
| 4.1.2    | 1000BASE-T.....                                   | 102        |
| 4.1.3    | 100BASE-TX .....                                  | 102        |
| 4.1.4    | 10BASE-T.....                                     | 103        |
| 4.1.5    | Taking Down the Link .....                        | 103        |
| 4.2      | Loopback .....                                    | 103        |
| 4.2.1    | MAC Loopback .....                                | 104        |
| 4.2.2    | Line Loopback .....                               | 104        |
| 4.3      | Power Management.....                             | 105        |
| 4.3.1    | Manual Power Down.....                            | 105        |
| 4.3.2    | Energy Detect.....                                | 105        |
| 4.4      | Auto-Negotiation .....                            | 107        |
| 4.4.1    | 802.3 Clause 28, 40, and 55 Auto-Negotiation..... | 107        |
| 4.4.2    | Exchange Complete — No Link Indicator.....        | 108        |
| 4.5      | Auto Downshift.....                               | 108        |
| 4.6      | Auto MDI/MDIX Crossover.....                      | 109        |
| 4.7      | Auto Polarity Correction .....                    | 110        |
| <b>5</b> | <b>Host Interface Unit (H Unit).....</b>          | <b>111</b> |
| 5.1      | Host Electrical Interface .....                   | 111        |
| 5.2      | PCS.....  | 112        |
| 5.2.1    | 5GBASE-R/2500BASE-X .....                         | 112        |
| 5.2.2    | 5GBASE-R.....                                     | 112        |
| 5.2.3    | 2500BASE-X.....                                   | 113        |
| 5.2.4    | SGMII (Media) .....                               | 113        |
| 5.3      | Loopback .....                                    | 115        |
| 5.4      | Power Management.....                             | 116        |
| <b>6</b> | <b>Electrical Specifications .....</b>            | <b>117</b> |
| 6.1      | Absolute Maximum Ratings .....                    | 117        |



---

|          |   |            |
|----------|---|------------|
| 6.2      | Recommended Operating Conditions .....                            | 118        |
| 6.3      | Package Thermal Information .....                                 | 119        |
| 6.3.1    | Thermal Conditions for 88E2010, 168-pin, HFCBGA Package .....     | 119        |
| 6.3.2    | Thermal Conditions for 88E2040L, 484-pin, HFCBGA Package .....    | 120        |
| 6.4      | Digital I/O Electrical Specifications .....                       | 121        |
| 6.4.1    | DC Operating Conditions .....                                     | 121        |
| 6.4.2    | Reset Timing .....  | 122        |
| 6.4.3    | LED to CONFIG Timing .....  | 122        |
| 6.4.4    | MDC/MDIO Management Interface Timing .....                        | 123        |
| 6.4.5    | JTAG Timing .....   | 125        |
| 6.4.6    | SPI Interface Timing .....  | 126        |
| 6.5      | Analog Electrical Specifications .....                            | 127        |
| 6.5.1    | SGMII Electrical Summary .....                                    | 127        |
| 6.5.2    | 2500BASE-X Electrical Summary .....                               | 128        |
| 6.5.3    | 5GBASE-R Electrical Summary .....                                 | 129        |
| 6.5.4    | 10BASE-Te, 100BASE-TX, and 1000BASE-T Electrical Parameters ..... | 130        |
| 6.5.5    | IEEE DC Transceiver Parameters .....                              | 131        |
| 6.6      | Reference Clock .....   | 132        |
| 6.6.1    | CLKP/N Timing — 156.25 MHz .....                                  | 132        |
| 6.6.2    | CLKP/N Timing — 50 MHz .....                                      | 133        |
| 6.6.3    | XTAL Timing Data .....  | 134        |
| 6.7      | Latency .....   | 135        |
| <b>7</b> | <b>Mechanical Drawing .....</b>                                   | <b>137</b> |
| 7.1      | 168-pin 10 mm x 12 mm HFCBGA Package Mechanical Drawings .....    | 137        |
| 7.2      | 484-pin 23 mm x 23 mm HFCBGA Package Mechanical Drawings .....    | 140        |
| <b>8</b> | <b>Part Order Numbering/Package Marking .....</b>                 | <b>143</b> |
| 8.1      | Part Order Numbering .....  | 143        |
| 8.2      | Package Marking .....   | 145        |
| 8.2.1    | Commercial Marking Examples .....                                 | 145        |
| 8.2.2    | Industrial Marking Examples .....                                 | 147        |



# List of Tables

|   |           |
|---|-----------|
| <b>Product Overview .....</b>   | <b>3</b>  |
| <b>1 General Chip Description.....</b>                                    | <b>13</b> |
| <b>2 Signal Description .....</b>   | <b>17</b> |
| Table 1: Pin Type Definitions .....                                       | 17        |
| Table 2: Media Dependent Interface.....                                   | 21        |
| Table 3: SERDES Interface .....   | 23        |
| Table 4: Clock/Reset/Reference .....                                      | 25        |
| Table 5: Management Interface .....                                       | 26        |
| Table 6: SPI Interface .....  | 27        |
| Table 7: LED .....  | 28        |
| Table 8: Configuration.....   | 29        |
| Table 9: JTAG Interface.....  | 29        |
| Table 10: Test Pins .....   | 30        |
| Table 11: Power and Ground.....   | 32        |
| Table 12: Power and Ground (Continued).....                               | 33        |
| Table 13: 88E2010 Pin List — Alphabetical by Signal Name .....            | 39        |
| Table 14: 88E2040L Pin List — Alphabetical by Signal Name .....           | 45        |
| <b>3 Functional Description .....</b>                                     | <b>62</b> |
| Table 15: Loopback Control.....   | 63        |
| Table 16: 88E2010 Device Configuration Mapping .....                      | 66        |
| Table 17: 88E2010 Three Bit Mapping .....                                 | 66        |
| Table 18: 88E2040L Device Configuration Mapping .....                     | 66        |
| Table 19: 88E2040L Device Three Bit Mapping .....                         | 67        |
| Table 20: Configuration Bit Definition .....                              | 67        |
| Table 21: CLK_SEL[1:0] Selection .....                                    | 70        |
| Table 22: Extensions for Management Frame Format for Indirect Access..... | 72        |
| Table 23: 88E2040L Device MDC/MDIO Interface Mapping .....                | 72        |
| Table 24: Dual LED Mode Behavior .....                                    | 76        |
| Table 25: Basic LED Status .....  | 76        |
| Table 26: Compound LED Status .....                                       | 76        |
| Table 27: Speed Blinking Sequence.....                                    | 77        |
| Table 28: Combo LED Modes.....  | 78        |
| Table 29: Combo Mode Timer Control.....                                   | 79        |
| Table 30: Combo LED Flash Mode.....                                       | 80        |
| Table 31: TAP Controller Opcodes .....                                    | 82        |
| Table 32: 88E2010 Boundary Scan Chain Order .....                         | 84        |
| Table 33: 88E2010 Boundary Scan Exclusion List .....                      | 86        |
| Table 34: 88E2040L Boundary Scan Chain Order .....                        | 87        |



|           |  |            |
|-----------|--|------------|
| Table 35: | 88E2040L Boundary Scan Exclusion List .....                    | 90         |
| Table 36: | ID CODE Instruction .....                                      | 93         |
| Table 37: | Test Receiver Hysteresis Setting .....                         | 94         |
| Table 38: | AC-Coupled Connection Fault Signature .....                    | 95         |
| Table 39: | DC-Coupled Connection Fault Signature.....                     | 96         |
| Table 40: | Reference Clock Options .....                                  | 98         |
| Table 41: | Signal Power Segment .....                                     | 100        |
| <b>4</b>  | <b>Copper Unit (T Unit).....</b>                               | <b>101</b> |
| Table 42: | Media Dependent Interface Pin Mapping.....                     | 109        |
| <b>5</b>  | <b>Host Interface Unit (H Unit).....</b>                       | <b>111</b> |
| Table 43: | 88E2010 Host Interface Configuration.....                      | 112        |
| Table 44: | 88E2040L Host Interface Configuration.....                     | 112        |
| <b>6</b>  | <b>Electrical Specifications .....</b>                         | <b>117</b> |
| Table 45: | Absolute Maximum Rating .....                                  | 117        |
| Table 46: | Recommended Operating Conditions.....                          | 118        |
| Table 47: | Thermal Conditions for 88E2010, 168-pin, HFCBGA Package .....  | 119        |
| Table 48: | Thermal Conditions for 88E2040L, 484-pin, HFCBGA Package ..... | 120        |
| Table 49: | DC Operating Conditions .....                                  | 121        |
| Table 50: | Reset Timing.....  | 122        |
| Table 51: | LED to CONFIG Timing .....                                     | 122        |
| Table 52: | MDC/MDIO Management Interface Timing.....                      | 123        |
| Table 53: | JTAG Timing .....  | 125        |
| Table 54: | SPI Interface Timing .....                                     | 126        |
| Table 55: | SGMII Electrical Summary.....                                  | 127        |
| Table 56: | 2500BASE-X Electrical Summary.....                             | 128        |
| Table 57: | 5GBASE-R Electrical Summary.....                               | 129        |
| Table 58: | IEEE DC Transceiver Parameters .....                           | 130        |
| Table 59: | IEEE DC Transceiver Parameters .....                           | 131        |
| Table 60: | CLKP/N Timing — 156.25 MHz .....                               | 132        |
| Table 61: | CLKP/N Timing — 50 MHz.....                                    | 133        |
| Table 62: | XTAL Timing .....  | 134        |
| Table 63: | Egress Path Latency Data .....                                 | 135        |
| Table 64: | Ingress Path Latency Data.....                                 | 136        |
| <b>7</b>  | <b>Mechanical Drawing .....</b>                                | <b>137</b> |
| Table 65: | 168-pin 10 mm x 12 mm HFCBGA Package Dimensions .....          | 139        |
| Table 66: | 484-pin 23 mm x 23 mm HFCBGA Package Dimensions .....          | 142        |
| <b>8</b>  | <b>Part Order Numbering/Package Marking.....</b>               | <b>143</b> |
| Table 67: | 88E2010/88E2040L Commercial Part Order Options .....           | 143        |
| Table 68: | 88E2010/88E2040L Industrial Part Order Options .....           | 144        |
| Table 69: | Document Change History.....                                   | 149        |

# List of Figures

|   |            |
|---|------------|
| <b>Product Overview .....</b>   | <b>3</b>   |
| Figure 1: 88E2010 Top-level Block Diagram .....                         | 4          |
| Figure 2: 88E2040L Top-level Block Diagram .....                        | 5          |
| <b>1 General Chip Description.....</b>                                  | <b>13</b>  |
| Figure 3: 88E2010 Device Functional Block Diagram.....                  | 14         |
| Figure 4: 88E2040L Device Functional Block Diagram.....                 | 15         |
| <b>2 Signal Description .....</b>                                       | <b>17</b>  |
| <b>3 Functional Description .....</b>                                   | <b>62</b>  |
| Figure 5: Loopback Paths .....  | 64         |
| Figure 6: Typical MDC/MDIO Read Operation.....                          | 71         |
| Figure 7: Typical MDC/MDIO Write Operation.....                         | 71         |
| Figure 8: 30 MHz MDC/MDIO Read Operation.....                           | 72         |
| Figure 9: SPI Read Array .....  | 73         |
| Figure 10: LED Chain.....   | 74         |
| Figure 11: Various LED Hookup Configurations .....                      | 75         |
| Figure 12: AC-Coupled Connection .....                                  | 95         |
| Figure 13: DC-Coupled Connection .....                                  | 96         |
| <b>4 Copper Unit (T Unit).....</b>                                      | <b>101</b> |
| Figure 14: 2.5GBASE-T and 5GBASE-T Data Path .....                      | 101        |
| Figure 15: 1000BASE-T Data Path.....                                    | 102        |
| Figure 16: 100BASE-TX Data Path.....                                    | 102        |
| Figure 17: 10BASE-T Data Path .....                                     | 103        |
| Figure 18: MAC Interface Loopback Diagram — Copper Media Interface..... | 104        |
| Figure 19: Line Loopback Diagram — Copper Media Interface.....          | 105        |
| <b>5 Host Interface Unit (H Unit).....</b>                              | <b>111</b> |
| Figure 20: Shallow Host Loopback .....                                  | 115        |
| Figure 21: Deep Line Loopback, No Ingress Blocking .....                | 115        |
| Figure 22: Deep Line Loopback, Ingress Blocking.....                    | 115        |
| <b>6 Electrical Specifications .....</b>                                | <b>117</b> |
| Figure 23: Reset Timing.....  | 122        |
| Figure 24: LED to CONFIG Timing .....                                   | 122        |
| Figure 25: MDC/MDIO Management Interface Timing.....                    | 123        |
| Figure 26: MDC/MDIO Input Hysteresis.....                               | 123        |
| Figure 27: MDC Read Turnaround Delay .....                              | 124        |
| Figure 28: JTAG Timing .....  | 125        |



---

|   |            |
|---|------------|
| Figure 29: SPI Interface Timing .....                                   | 126        |
| Figure 30: XTAL Timing .....  | 134        |
| <b>7 Mechanical Drawing .....</b>                                       | <b>137</b> |
| Figure 31: 168-pin 10 mm x 12 mm HFCBGA Top and Side View .....         | 137        |
| Figure 32: 168-pin 10 mm x 12 mm HFCBGA Bottom View .....               | 138        |
| Figure 33: 484-pin 23 mm x 23 mm HFCBGA Top and Side View .....         | 140        |
| Figure 34: 484-pin 23 mm x 23 mm HFCBGA Bottom View .....               | 141        |
| <b>8 Part Order Numbering/Package Marking.....</b>                      | <b>143</b> |
| Figure 35: Sample Part Number .....                                     | 143        |
| Figure 36: 88E2010 Commercial Package Marking and Pin 1 Location .....  | 145        |
| Figure 37: 88E2040L Commercial Package Marking and Pin 1 Location ..... | 146        |
| Figure 38: 88E2010 Industrial Package Marking and Pin 1 Location .....  | 147        |
| Figure 39: 88E2040L Industrial Package Marking and Pin 1 Location ..... | 148        |

# 1

## General Chip Description

The 88E2010 and 88E2040L devices are a family of one- and four-port integrated multi-speed copper Ethernet Transceivers.

The host interface to the MAC is via 5GBASE-R, 2500BASE-X, or SGMII interface.



Figure 3: 88E2010 Device Functional Block Diagram

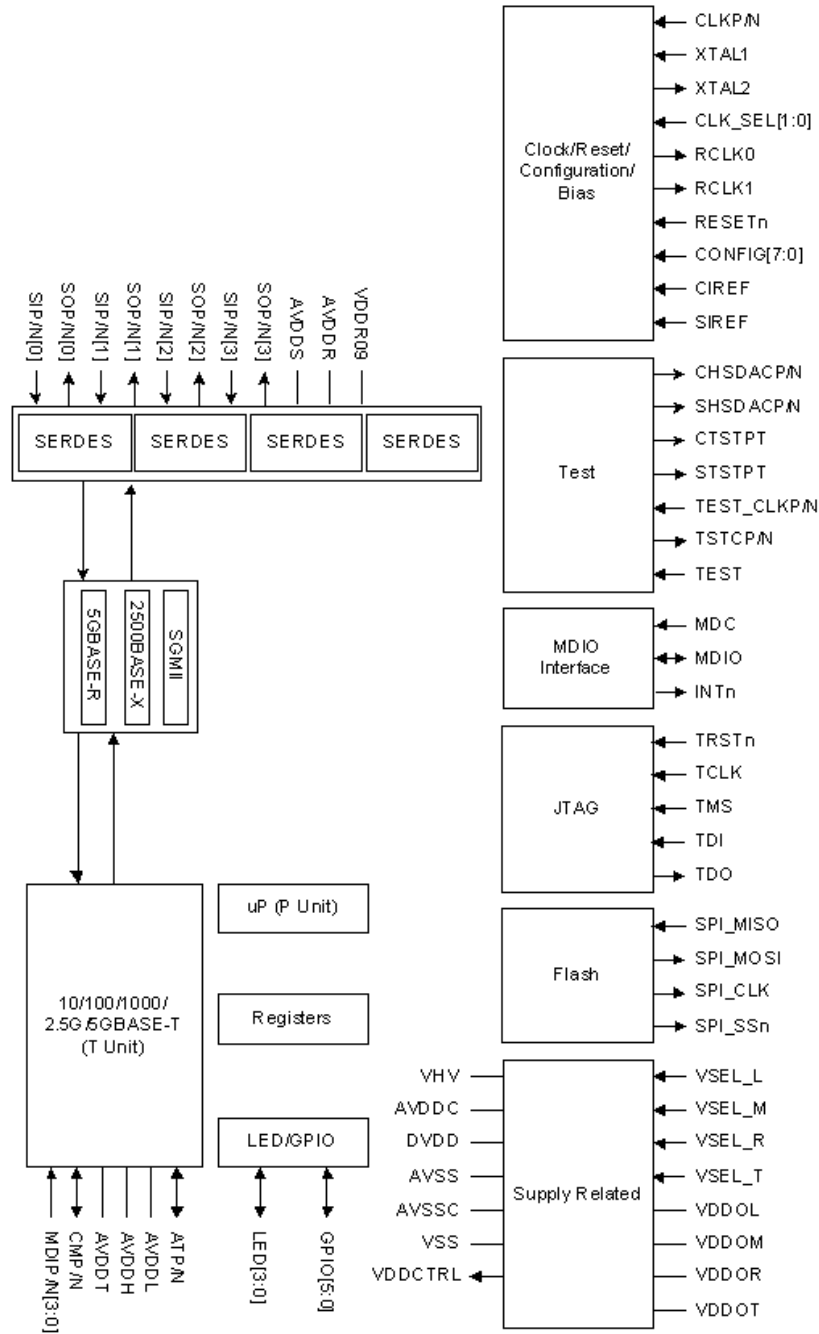
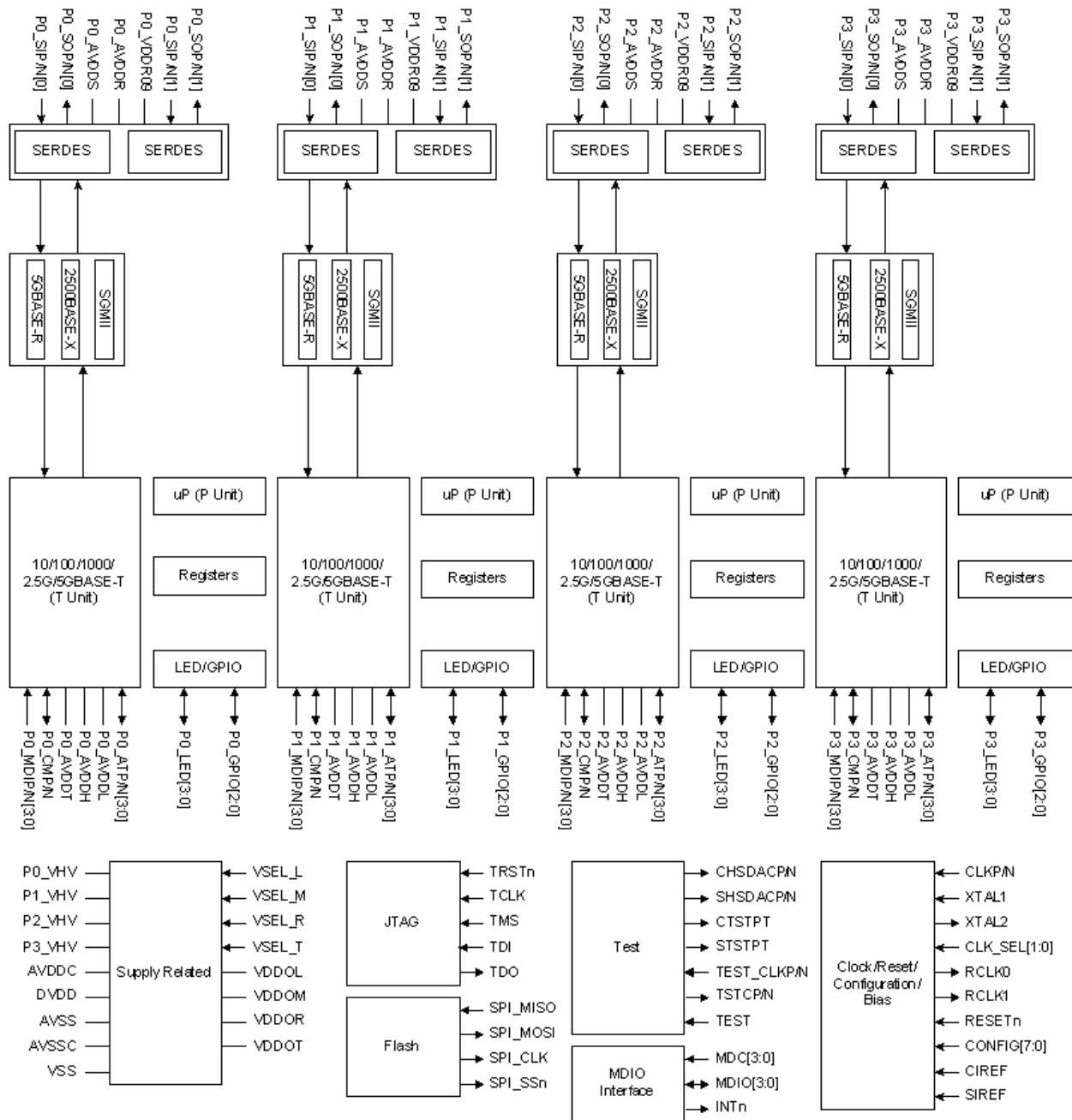

Figure 4: 88E2040L Device Functional Block Diagram





The datasheet is divided as follows:

Section 1 describes the general function of the device.

Section 2 describes the pinout and pin definitions.

Section 3 describes the detailed device functions.

Section 4 describes the copper interface functions (T Unit).

Section 5 describes the MAC interface functions (H Unit).

Section 6 describes the electrical specifications.

Section 7 describes the package mechanical dimensions.

Section 8 describes the order information.

The conventions used in the datasheet are as follows.

All registers are specified per IEEE 802.3 section 45. The format is X.Y, X.Y.Z, or X.Y.Z1:Z2, where X is the device address in decimal from 0 to 31, Y is the register address in hexadecimal from 0000 to FFFF, and Z is the bit in decimal from 0 to 15.

T Unit – 10/100/1000/2.5G/5GBASE-T interface.

H Unit – SGMII/2500BASE-X/5GBASE-R host interface.



**Note**

Unless otherwise noted, all descriptions apply to the one-, two-, and four-port devices.

---



# 2 Signal Description

**Table 1: Pin Type Definitions**

| Pin Type | Definition            |
|----------|-----------------------|
| H        | Input with hysteresis |
| I/O      | Input and output      |
| I        | Input only            |
| O        | Output only           |
| PU       | Internal pull-up      |
| PD       | Internal pull-down    |
| D        | Open drain output     |
| Z        | Tri-state output      |
| mA       | DC sink capability    |



## 2.1 Pin Maps

### 2.1.1 88E2010 Device Pin Map

|   | 1         | 2          | 3         | 4       | 5       | 6      | 7      | 8       | 9       | 10      | 11                  | 12                 |   |
|---|-----------|------------|-----------|---------|---------|--------|--------|---------|---------|---------|---------------------|--------------------|---|
| A | VSS       | AVSS       | SOP[3]    | AVSS    | SOP[2]  | AVSS   | SOP[1] | AVSS    | SOP[0]  | AVSS    | SHSDACP             | AVSS               | A |
| B | MDC       | TEST       | SON[3]    | AVSS    | SON[2]  | AVSS   | SON[1] | AVSS    | SON[0]  | AVSS    | SHSDACN             | SIREF              | B |
| C | MDIO      | INTn       | AVSS      | SIP[3]  | AVSS    | SIP[2] | AVSS   | SIP[1]  | AVSS    | SIP[0]  | AVSS                | STSTPT             | C |
| D | CONFIG[1] | CONFIG[2]  | CONFIG[6] | SIN[3]  | AVSS    | SIN[2] | AVSS   | SIN[1]  | AVDD5   | SIN[0]  | SPI_SS <sub>n</sub> | RESET <sub>n</sub> | D |
| E | LED[0]    | CONFIG[3]  | AVDD5     | AVDDR   | AVSS    | VDDR09 | AVSS   | AVDDR   | AVDDC   | VSEL_R  | SPI_MOSI            | SPI_MISO           | E |
| F | LED[1]    | LED[3]     | VSEL_M    | VSS     | DVDD    | VSS    | DVDD   | VSS     | VHV     | GPIO[0] | VSS                 | SPI_CLK            | F |
| G | LED[2]    | CONFIG[4]  | VDD0M     | VSS     | DVDD    | VSS    | DVDD   | VSS     | VDDOR   | GPIO[1] | RCLK1               | GPIO[5]            | G |
| H | CONFIG[0] | CONFIG[5]  | CONFIG[7] | VSS     | DVDD    | VSS    | DVDD   | VSS     | VSEL_T  | GPIO[2] | GPIO[4]             | RCLK0              | H |
| J | CLKN      | VDDCTRL    | VDD0L     | VSS     | DVDD    | VSS    | DVDD   | VSS     | VDD0T   | VSS     | TMS                 | TDO                | J |
| K | CLKP      | CLK_SEL[0] | VSEL_L    | AVDDL   | AVSS    | AVDDL  | AVSS   | AVDDL   | AVSS    | GPIO[3] | TDI                 | TCK                | K |
| L | XTAL2     | CLK_SEL[1] | ATN       | AVSS    | AVDDH   | AVSS   | AVDDH  | AVSS    | AVDDH   | AVSS    | TEST_CLKP           | TRST <sub>n</sub>  | L |
| M | XTAL1     | AVDDC      | ATP       | AVDDT   | AVSS    | AVDDT  | AVSS   | AVDDT   | AVSS    | AVDDC   | TEST_CLKN           | CTSTPT             | M |
| N | AVSSC     | TSTCN      | AVSS      | MDIP[3] | MDIN[2] | AVDDT  | CMN    | MDIP[1] | MDIN[0] | AVSS    | CHSDACN             | CIREF              | N |
| P | AVSS      | TSTCP      | AVSS      | MDIN[3] | MDIP[2] | AVSS   | CMP    | MDIN[1] | MDIP[0] | AVSS    | CHSDACP             | AVSS               | P |
|   | 1         | 2          | 3         | 4       | 5       | 6      | 7      | 8       | 9       | 10      | 11                  | 12                 |   |

(Top View)

## 2.1.2 88E2040L Device Pin Map

Due to the large number of pins, the package is depicted graphically over two pages.

|    | 1         | 2          | 3          | 4          | 5          | 6         | 7          | 8          | 9          | 10         | 11      |    |
|----|-----------|------------|------------|------------|------------|-----------|------------|------------|------------|------------|---------|----|
| A  | AVSS      | R0_SOR[0]  | AVSS       | R0_SOR[1]  | AVSS       | P1_SOR[1] | AVSS       | P1_SOR[0]  | AVSS       | MDIO[1]    | MDC[1]  | A  |
| B  | AVSS      | R0_SON[0]  | AVSS       | R0_SON[1]  | AVSS       | P1_SON[1] | AVSS       | P1_SON[0]  | AVSS       | VSS        | MDC[0]  | B  |
| C  | R0_SIF[0] | AVSS       | R0_SIF[1]  | AVSS       | AVSS       | AVSS      | P1_SIF[1]  | AVSS       | P1_SIF[0]  | AVSS       | MDIO[0] | C  |
| D  | R0_SIN[0] | R0_AVDDS   | R0_SIN[1]  | R0_AVDDS   | AVSS       | P1_AVDDS  | P1_SIN[1]  | P1_AVDDS   | P1_SIN[0]  | AVSS       | INTn    | D  |
| E  | AVSS      | R0_VDDR09  | AVSS       | R0_AVDDR   | AVSS       | P1_AVDDR  | AVSS       | P1_VDDR09  | AVSS       | AVSS       | VDDOM   | E  |
| F  | P3_LED[0] | P3_LED[1]  | P3_LED[2]  | P3_LED[3]  | R0_VHV     | VSS       | DVDD       | VSS        | DVDD       | VSS        | P1_VHV  | F  |
| G  | P2_LED[0] | P2_LED[1]  | VSS        | P2_LED[3]  | CONFIG[7]  | VSS       | DVDD       | VSS        | DVDD       | VSS        | DVDD    | G  |
| H  | CONFIG[4] | P2_LED[2]  | P1_LED[2]  | CONFIG[5]  | VDDOL      | VSS       | DVDD       | VSS        | DVDD       | VSS        | DVDD    | H  |
| J  | P1_LED[0] | VSS        | P1_LED[1]  | P1_LED[3]  | CONFIG[6]  | VSS       | DVDD       | VSS        | DVDD       | VSS        | DVDD    | J  |
| K  | R0_LED[0] | R0_LED[1]  | R0_LED[2]  | R0_LED[3]  | VDDOL      | VSS       | DVDD       | VSS        | DVDD       | VSS        | DVDD    | K  |
| L  | CONFIG[0] | CONFIG[1]  | VSS        | CONFIG[3]  | VSEL_L     | VSS       | DVDD       | VSS        | DVDD       | VSS        | DVDD    | L  |
| M  | AVSS      | CONFIG[2]  | CLK_SEL[0] | CLK_SEL[1] | AVSS       | AVSS      | AVSS       | AVSS       | AVSS       | AVSS       | AVSS    | M  |
| N  | CLKN      | R0_AVDDH   | R0_AVDDH   | R0_AVDDH   | R0_AVDDH   | AVSS      | P1_AVDDH   | P1_AVDDH   | P1_AVDDH   | P1_AVDDH   | AVSS    | N  |
| P  | CLKP      | AVSS       | AVSS       | AVSS       | AVSS       | AVSS      | AVSS       | AVSS       | AVSS       | AVSS       | AVSS    | P  |
| R  | XTAL2     | R0_AVDDL   | R0_AVDDL   | R0_AVDDL   | R0_AVDDL   | AVSS      | P1_AVDDL   | P1_AVDDL   | P1_AVDDL   | P1_AVDDL   | AVSS    | R  |
| T  | XTAL1     | R0_AVDDT   | R0_AVDDT   | R0_AVDDT   | R0_AVDDT   | AVSS      | P1_AVDDT   | P1_AVDDT   | P1_AVDDT   | P1_AVDDT   | AVSS    | T  |
| U  | AVSSC     | AVSS       | AVSS       | AVSS       | AVSS       | AVSS      | AVSS       | AVSS       | AVSS       | AVSS       | AVSS    | U  |
| V  | TSTCN     | R0_ATN[0]  | R0_ATN[1]  | R0_ATN[2]  | R0_ATN[3]  | AVSS      | P1_ATN[3]  | P1_ATN[2]  | P1_ATN[1]  | P1_ATN[0]  | AVSS    | V  |
| W  | TSTCP     | R0_ATR[0]  | R0_ATR[1]  | R0_ATR[2]  | R0_ATR[3]  | AVSS      | P1_ATR[3]  | P1_ATR[2]  | P1_ATR[1]  | P1_ATR[0]  | AVSS    | W  |
| Y  | AVDDC     | AVSS       | R0_CMP     | R0_CMP     | AVSS       | AVSS      | AVSS       | P1_CMP     | P1_CMP     | AVSS       | AVSS    | Y  |
| AA | AVSS      | R0_MDI[0]  | R0_MDI[1]  | R0_MDI[2]  | R0_MDI[3]  | AVSS      | P1_MDI[3]  | P1_MDI[2]  | P1_MDI[1]  | P1_MDI[0]  | AVSS    | AA |
| AB | AVSS      | R0_MDIR[0] | R0_MDIR[1] | R0_MDIR[2] | R0_MDIR[3] | AVSS      | P1_MDIR[3] | P1_MDIR[2] | P1_MDIR[1] | P1_MDIR[0] | AVSS    | AB |
|    | 1         | 2          | 3          | 4          | 5          | 6         | 7          | 8          | 9          | 10         | 11      |    |

(Top View)



|    | 12         | 13         | 14         | 15         | 16        | 17         | 18         | 19         | 20         | 21        | 22        |    |
|----|------------|------------|------------|------------|-----------|------------|------------|------------|------------|-----------|-----------|----|
| A  | MDC[2]     | MDIO[2]    | AVSS       | F2_SOR[0]  | AVSS      | F2_SOR[1]  | AVSS       | F3_SOR[1]  | AVSS       | F3_SOR[0] | AVSS      | A  |
| B  | MDC[3]     | VSS        | AVSS       | F2_SON[0]  | AVSS      | F2_SON[1]  | AVSS       | F3_SON[1]  | AVSS       | F3_SON[0] | AVSS      | B  |
| C  | MDIO[3]    | AVSS       | F2_SIR[0]  | AVSS       | F2_SIR[1] | AVSS       | AVSS       | AVSS       | F3_SIR[1]  | AVSS      | F3_SIR[0] | C  |
| D  | TEST       | AVSS       | F2_SIN[0]  | F2_AVDDS   | F2_SIN[1] | F2_AVDDS   | AVSS       | F3_AVDDS   | F3_SIN[1]  | F3_AVDDS  | F3_SIN[0] | D  |
| E  | VSEL_M     | F2_VDDR09  | AVSS       | F2_AVDDR   | AVSS      | F3_AVDDR   | AVSS       | F3_VDDR09  | AVSS       | SREF      | AVSS      | E  |
| F  | F2_VHV     | DVDD       | VSS        | DVDD       | VSS       | DVDD       | F3_VHV     | SHSDACP    | SHSDACN    | AVDDC     | STSTPT    | F  |
| G  | VSS        | DVDD       | VSS        | DVDD       | VSS       | DVDD       | VSS        | VDDOR      | SF_MDSI    | SF_SSh    | RESETh    | G  |
| H  | VSS        | DVDD       | VSS        | DVDD       | VSS       | DVDD       | VSS        | VSEL_R     | P1_GRO[2]  | VSS       | P0_GRO[2] | H  |
| J  | VSS        | DVDD       | VSS        | DVDD       | VSS       | DVDD       | VSS        | VDDOR      | SF_MSO     | F2_GRO[2] | RCLK1     | J  |
| K  | VSS        | DVDD       | VSS        | DVDD       | VSS       | DVDD       | VSS        | VDDOT      | SF_CLK     | F3_GRO[2] | RCLK0     | K  |
| L  | VSS        | DVDD       | VSS        | DVDD       | VSS       | DVDD       | VSS        | VSEL_T     | P0_GRO[1]  | VSS       | P0_GRO[0] | L  |
| M  | AVSS       | AVSS       | AVSS       | AVSS       | AVSS      | AVSS       | AVSS       | AVSS       | P1_GRO[1]  | F2_GRO[1] | P1_GRO[0] | M  |
| N  | F2_AVDDH   | F2_AVDDH   | F2_AVDDH   | F2_AVDDH   | AVSS      | F3_AVDDH   | F3_AVDDH   | F3_AVDDH   | F3_AVDDH   | F3_GRO[1] | F2_GRO[0] | N  |
| P  | AVSS       | AVSS       | AVSS       | AVSS       | AVSS      | AVSS       | AVSS       | AVSS       | AVSS       | VSS       | F3_GRO[0] | P  |
| R  | F2_AVDDL   | F2_AVDDL   | F2_AVDDL   | F2_AVDDL   | AVSS      | F3_AVDDL   | F3_AVDDL   | F3_AVDDL   | F3_AVDDL   | TCK       | TRSTh     | R  |
| T  | F2_AVDDT   | F2_AVDDT   | F2_AVDDT   | F2_AVDDT   | AVSS      | F3_AVDDT   | F3_AVDDT   | F3_AVDDT   | F3_AVDDT   | TDI       | TEST_CLKN | T  |
| U  | AVSS       | AVSS       | AVSS       | AVSS       | AVSS      | AVSS       | AVSS       | AVSS       | AVSS       | TDO       | TEST_CLKP | U  |
| V  | F2_ATN[0]  | F2_ATN[1]  | F2_ATN[2]  | F2_ATN[3]  | AVSS      | F3_ATN[3]  | F3_ATN[2]  | F3_ATN[1]  | F3_ATN[0]  | TMS       | AVSS      | V  |
| W  | F2_ATR[0]  | F2_ATR[1]  | F2_ATR[2]  | F2_ATR[3]  | AVSS      | F3_ATR[3]  | F3_ATR[2]  | F3_ATR[1]  | F3_ATR[0]  | AVDDC     | CTSTPT    | W  |
| Y  | AVSS       | F2_CMN     | F2_CMP     | AVSS       | AVSS      | AVSS       | F3_CMP     | F3_CMN     | AVSS       | AVDDC     | CREF      | Y  |
| AA | F2_MDN[0]  | F2_MDN[1]  | F2_MDN[2]  | F2_MDN[3]  | AVSS      | F3_MDN[3]  | F3_MDN[2]  | F3_MDN[1]  | F3_MDN[0]  | CHSDACN   | AVSS      | AA |
| AB | F2_MDIR[0] | F2_MDIR[1] | F2_MDIR[2] | F2_MDIR[3] | AVSS      | F3_MDIR[3] | F3_MDIR[2] | F3_MDIR[1] | F3_MDIR[0] | CHSDACP   | AVSS      | AB |
|    | 12         | 13         | 14         | 15         | 16        | 17         | 18         | 19         | 20         | 21        | 22        |    |

(Top View)



## 2.2 Pin Description



**Note**

88E2010 device pin names are not prefixed with P0\_.

**Table 2: Media Dependent Interface**

| 88E2010 Pin # | 88E2040L Pin # | Pin Name                 | Pin Type | Description   |
|---------------|----------------|--------------------------|----------|---|
| P9<br>N9      | AB2<br>AA2     | P0_MDIP[0]<br>P0_MDIN[0] | I/O      | Media Dependent Interface[0], Port 0.<br>In 2.5G/5GBASE-T and 1000BASE-T modes in MDI configuration, MDIP/N[0] correspond to BI_DA±.<br>In MDIX configuration, MDIP/N[0] correspond to BI_DB±.<br>In 100BASE-TX and 10BASE-T modes in MDI configuration, MDIP/N[0] are used for the transmit pair.<br>In MDIX configuration, MDIP/N[0] are used for the receive pair.<br>MDIP/N[0] should be tied to ground if not used.<br>The device contains an internal 100Ω resistor between the MDIP/N[0] pins. |
| N8<br>P8      | AB3<br>AA3     | P0_MDIP[1]<br>P0_MDIN[1] | I/O      | Media Dependent Interface[1], Port 0.<br>In 2.5G/5GBASE-T and 1000BASE-T modes in MDIX configuration, MDIP/N[1] correspond to BI_DA±.<br>In MDI configuration, MDIP/N[1] correspond to BI_DB±.<br>In 100BASE-TX and 10BASE-T modes in MDIX configuration, MDIP/N[1] are used for the transmit pair.<br>In MDI configuration, MDIP/N[1] are used for the receive pair.<br>MDIP/N[1] should be tied to ground if not used.<br>The device contains an internal 100Ω resistor between the MDIP/N[1] pins. |
| P5<br>N5      | AB4<br>AA4     | P0_MDIP[2]<br>P0_MDIN[2] | I/O      | Media Dependent Interface[2], Port 0.<br>In 2.5G/5GBASE-T and 1000BASE-T modes in MDI configuration, MDIP/N[2] correspond to BI_DC±.<br>In MDIX configuration, MDIP/N[2] correspond to BI_DD±.<br>In 100BASE-TX and 10BASE-T modes, these pins are floating.<br>MDIP/N[2] should be tied to ground if not used.<br>The device contains an internal 100Ω resistor between the MDIP/N[2] pins.  |



Table 2: Media Dependent Interface (Continued)

| 88E2010 Pin # | 88E2040L Pin # | Pin Name                 | Pin Type | Description   |
|---------------|----------------|--------------------------|----------|---|
| N4<br>P4      | AB5<br>AA5     | P0_MDIP[3]<br>P0_MDIN[3] | I/O      | Media Dependent Interface[3], Port 0.<br>In 2.5G/5GBASE-T and 1000BASE-T modes in MDIX configuration, MDIP/N[3] correspond to BI_DC±.<br>In MDI configuration, MDIP/N[3] correspond to BI_DD±.<br>In 100BASE-TX and 10BASE-T modes these pins are floating.<br>MDIP/N[3] should be tied to ground if not used.<br>The device contains an internal 100Ω resistor between the MDIP/N[3] pins. |
| --<br>--      | AB10<br>AA10   | P1_MDIP[0]<br>P1_MDIN[0] | I/O      | Media Dependent Interface[0], Port 1.   |
| --<br>--      | AB9<br>AA9     | P1_MDIP[1]<br>P1_MDIN[1] | I/O      | Media Dependent Interface[1], Port 1.   |
| --<br>--      | AB8<br>AA8     | P1_MDIP[2]<br>P1_MDIN[2] | I/O      | Media Dependent Interface[2], Port 1.   |
| --<br>--      | AB7<br>AA7     | P1_MDIP[3]<br>P1_MDIN[3] | I/O      | Media Dependent Interface[3], Port 1.   |
| --<br>--      | AB12<br>AA12   | P2_MDIP[0]<br>P2_MDIN[0] | I/O      | Media Dependent Interface[0], Port 2.   |
| --<br>--      | AB13<br>AA13   | P2_MDIP[1]<br>P2_MDIN[1] | I/O      | Media Dependent Interface[1], Port 2.   |
| --<br>--      | AB14<br>AA14   | P2_MDIP[2]<br>P2_MDIN[2] | I/O      | Media Dependent Interface[2], Port 2.   |
| --<br>--      | AB15<br>AA15   | P2_MDIP[3]<br>P2_MDIN[3] | I/O      | Media Dependent Interface[3], Port 2.   |
| --<br>--      | AB20<br>AA20   | P3_MDIP[0]<br>P3_MDIN[0] | I/O      | Media Dependent Interface[0], Port 3.   |
| --<br>--      | AB19<br>AA19   | P3_MDIP[1]<br>P3_MDIN[1] | I/O      | Media Dependent Interface[1], Port 3.   |
| --<br>--      | AB18<br>AA18   | P3_MDIP[2]<br>P3_MDIN[2] | I/O      | Media Dependent Interface[2], Port 3.   |
| --<br>--      | AB17<br>AA17   | P3_MDIP[3]<br>P3_MDIN[3] | I/O      | Media Dependent Interface[3], Port 3.   |
| P7<br>N7      | Y4<br>Y3       | P0_CMP<br>P0_CMN         | I        | Media Dependent Interface, optional common mode sense, Port 0   |
| --<br>--      | Y8<br>Y9       | P1_CMP<br>P1_CMN         | I        | Media Dependent Interface, optional common mode sense, Port 1   |
| --<br>--      | Y14<br>Y13     | P2_CMP<br>P2_CMN         | I        | Media Dependent Interface, optional common mode sense, Port 2   |
| --<br>--      | Y18<br>Y19     | P3_CMP<br>P3_CMN         | I        | Media Dependent Interface, optional common mode sense, Port 3   |

**Table 3: SERDES Interface**

| 88E2010<br>Pin #     | 88E2040L<br>Pin #    | Pin Name                             | Pin<br>Type | Description  |
|----------------------|----------------------|--------------------------------------|-------------|--|
| C10<br>D10           | C1<br>D1             | P0_SIP[0]<br>P0_SIN[0]               | I           | Host Interface Input Lane 0, Port 0<br>5GBASE-R, 2500BASE-X, SGMII                                   |
| C8<br>D8             | C3<br>D3             | P0_SIP[1]<br>P0_SIN[1]               | I           | Host Interface Input Lane 1 Port 0   |
| C6<br>D6<br>C4<br>D4 | --<br>--<br>--<br>-- | SIP[2]<br>SIN[2]<br>SIP[3]<br>SIN[3] | I           | Host Interface Input Lane 2 and 3.   |
| --<br>--             | C9<br>D9             | P1_SIP[0]<br>P1_SIN[0]               | I           | Host Interface Input Lane 0, Port 1<br>5GBASE-R, 2500BASE-X, SGMII                                   |
| --<br>--             | C7<br>D7             | P1_SIP[1]<br>P1_SIN[1]               | I           | Host Interface Input Lane 1, Port 1  |
| --<br>--             | C14<br>D14           | P2_SIP[0]<br>P2_SIN[0]               | I           | Host Interface Input Lane 0, Port 2<br>5GBASE-R, 2500BASE-X, SGMII,                                  |
| --<br>--             | C16<br>D16           | P2_SIP[1]<br>P2_SIN[1]               | I           | Host Interface Input Lane 1, Port 2  |
| --<br>--             | C22<br>D22           | P3_SIP[0]<br>P3_SIN[0]               | I           | Host Interface Input Lane 0, Port 3<br>5GBASE-R, 2500BASE-X, SGMII                                   |
| --<br>--             | C20<br>D20           | P3_SIP[1]<br>P3_SIN[1]               | I           | Host Interface Input Lane 1, Port 3  |
| A9<br>B9             | A2<br>B2             | P0_SOP[0]<br>P0_SON[0]               | O           | Host Interface Output Lane 0, Port 0<br>5GBASE-R, 2500BASE-X, SGMII                                  |
| A7<br>B7             | A4<br>B4             | P0_SOP[1]<br>P0_SON[1]               | O           | Host Interface Output Lane 1 Port 0  |
| A5<br>B5<br>A3<br>B3 | --<br>--<br>--<br>-- | SOP[2]<br>SON[2]<br>SOP[3]<br>SON[3] | O           | Host Interface Output Lane 2 and 3.  |
| --<br>--             | A8<br>B8             | P1_SOP[0]<br>P1_SON[0]               | O           | Host Interface Output Lane 0, Port 1<br>5GBASE-R, 2500BASE-X, SGMII                                  |
| --<br>--             | A6<br>B6             | P1_SOP[1]<br>P1_SON[1]               | O           | Host Interface Output Lane 1, Port 1   |
| --<br>--             | A15<br>B15           | P2_SOP[0]<br>P2_SON[0]               | O           | Host Interface Output Lane 0, Port 2<br>5GBASE-R, 2500BASE-X, SGMII, lane 0                          |
| --<br>--             | A17<br>B17           | P2_SOP[1]<br>P2_SON[1]               | O           | Host Interface Output Lane 1, Port 2<br>These signals can be configured as lane 1 host<br>interface. |
| --<br>--             | A21<br>B21           | P3_SOP[0]<br>P3_SON[0]               | O           | Host Interface Output Lane 0, Port 3<br>5GBASE-R, 2500BASE-X, SGMII, lane 0                          |



**Table 3: SERDES Interface (Continued)**

| 88E2010<br>Pin # | 88E2040L<br>Pin # | Pin Name               | Pin<br>Type | Description  |
|------------------|-------------------|------------------------|-------------|--|
| --<br>--         | A19<br>B19        | P3_SOP[1]<br>P3_SON[1] | O           | Host Interface Output Lane 1, Port 3<br>These signals can be configured as lane 1 host<br>interface. |



Table 4: Clock/Reset/Reference

| 88E2010 Pin # | 88E2040L Pin # | Pin Name     | Pin Type | Description  |
|---------------|----------------|--------------|----------|--|
| N12           | Y22            | CIREF        | I        | Analog Reference, Copper. This pin should be connected via a 4.99 kΩ 1% resistor to VSS.                       |
| B12           | E21            | SIREF        | I        | Analog Reference, SERDES. This pin should be connected via a 4.99 kΩ 1% resistor to VSS                        |
| K1<br>J1      | P1<br>N1       | CLKP<br>CLKN | I        | 156.25 MHz or 50 MHz Differential Reference Clock Input. ±50 ppm tolerance.                                    |
| M1            | T1             | XTAL1        | I        | 50 MHz crystal input<br><b>NOTE:</b> 50 MHz crystal operation is only supported for commercial-grade devices.  |
| L1            | R1             | XTAL2        | O        | 50 MHz crystal output<br><b>NOTE:</b> 50 MHz crystal operation is only supported for commercial-grade devices. |
| H12           | K22            | RCLK0        | O        | Recovered Clock Output 0 to 25 MHz   |
| G11           | J22            | RCLK1        | O        | Recovered Clock Output 1 to 25 MHz   |
| D12           | G22            | RESETn       | I        | Reset<br>0 = Reset<br>1 = Normal   |

**Table 5: Management Interface**

| 88E2010<br>Pin #     | 88E2040L<br>Pin #        | Pin Name                                 | Pin<br>Type | Description  |
|----------------------|--------------------------|--|-------------|--|
| B1<br>--<br>--<br>-- | B11<br>A11<br>A12<br>B12 | MDC[0]<br>MDC[1]<br>MDC[2]<br>MDC[3]     | I           | <p>Management Clock pin.</p> <p>MDC is the management data clock reference for the serial management interface. A continuous clock stream is not expected. The maximum continuous frequency supported is 12.5 MHz. A 30 MHz non-continuous mode is also supported.</p> <p>88E2040L:<br/>If the device is configured to shared MDC/MDIO mode, then MDC[2]/MDIO[2] is used to access all four ports.<br/>If the device is configured to dual MDC/MDIO mode, then MDC[1]/MDIO[1] is used to access Ports 0 and 1 while MDC[2]/MDIO[2] is used to access Ports 2 and 3.<br/>If MDC[x] is unused, then it should be tied low.</p> |
| C1<br>--<br>--<br>-- | C11<br>A10<br>A13<br>C12 | MDIO[0]<br>MDIO[1]<br>MDIO[2]<br>MDIO[3] | I/O         | <p>Management Data pin.</p> <p>MDIO is the management data. MDIO transfers management data in and out of the device synchronously to MDC.</p> <p>This pin requires a pull-up resistor in a range from 1.5 k<math>\Omega</math> to 10 k<math>\Omega</math>.</p> <p>If MDIO[x] is unused, then it should be left floating.</p>   |
| C2                   | D11                      | INTn                                     | OD          | Interrupt pin. (Polarity programmable)   |

**Table 6: SPI Interface**

| 88E2010<br>Pin # | 88E2040L<br>Pin # | Pin Name            | Pin<br>Type | Description       |
|------------------|-------------------|---------------------|-------------|-------------------|
| D11              | G21               | SPI_SS <sub>n</sub> | O           | SPI device enable |
| F12              | K20               | SPI_CLK             | O           | SPI clock         |
| E11              | G20               | SPI_MOSI            | O           | SPI serial out    |
| E12              | J20               | SPI_MISO            | I           | SPI serial in     |



Table 7: LED

| 88E2010<br>Pin #     | 88E2040L<br>Pin #    | Pin Name   | Pin<br>Type | Description         |
|----------------------|----------------------|--|-------------|---------------------|
| E1<br>F1<br>G1<br>F2 | K1<br>K2<br>K3<br>K4 | P0_LED[0]<br>P0_LED[1]<br>P0_LED[2]<br>P0_LED[3] | I/O         | LED Outputs, Port 0 |
| --<br>--<br>--<br>-- | J1<br>J3<br>H3<br>J4 | P1_LED[0]<br>P1_LED[1]<br>P1_LED[2]<br>P1_LED[3] | I/O         | LED Outputs, Port 1 |
| --<br>--<br>--<br>-- | G1<br>G2<br>H2<br>G4 | P2_LED[0]<br>P2_LED[1]<br>P2_LED[2]<br>P2_LED[3] | I/O         | LED Outputs, Port 2 |
| --<br>--<br>--<br>-- | F1<br>F2<br>F3<br>F4 | P3_LED[0]<br>P3_LED[1]<br>P3_LED[2]<br>P3_LED[3] | I/O         | LED Outputs, Port 3 |
| F10<br>G10<br>H10    | L22<br>L20<br>H22    | Reserved<br>Reserved<br>Reserved                 | –           | Reserved            |
| K10<br>H11<br>G12    | --<br>--<br>--       | Reserved<br>Reserved<br>Reserved                 | –           | Reserved            |
| --<br>--<br>--       | M22<br>M20<br>H20    | Reserved<br>Reserved<br>Reserved                 | –           | Reserved            |
| --<br>--<br>--       | N22<br>M21<br>J21    | Reserved<br>Reserved<br>Reserved                 | –           | Reserved            |
| --<br>--<br>--       | P22<br>N21<br>K21    | Reserved<br>Reserved<br>Reserved                 | –           | Reserved            |

**Table 8: Configuration**

| 88E2010<br>Pin #                             | 88E2040L<br>Pin #                            | Pin Name   | Pin Type | Description  |
|--|--|--|----------|--|
| K2<br>L2                                     | M3<br>M4                                     | CLK_SEL[0]<br>CLK_SEL[1]   | I, PD    | Reference clock selection<br>00 = 50 MHz XTAL1/2<br>01 = 50 MHz CLKP/N<br>10 = 156.25 MHz CLKP/N<br>11 = Reserved<br><b>NOTE:</b> 50 MHz crystal operation is only supported for commercial-grade devices. |
| H1<br>D1<br>D2<br>E2<br>G2<br>H2<br>D3<br>H3 | L1<br>L2<br>M2<br>L4<br>H1<br>H4<br>J5<br>G5 | CONFIG[0]<br>CONFIG[1]<br>CONFIG[2]<br>CONFIG[3]<br>CONFIG[4]<br>CONFIG[5]<br>CONFIG[6]<br>CONFIG[7] | I        | Hardware Configuration   |
| K3   | L5   | VSEL_L   | I        | VDDOL Voltage Level Select<br>VSS = 2.5V/3.3V, VDDOL = 1.5V/1.8V   |
| F3   | E12  | VSEL_M   | I        | VDDOM Voltage Level Select<br>VSS = 2.5V/3.3V, VDDOM = 1.2V/1.5V/1.8V  |
| E10  | H19  | VSEL_R   | I        | VDDOR Voltage Level Select<br>VSS = 2.5V/3.3V, VDDOR = 1.5V/1.8V   |
| H9   | L19  | VSEL_T   | I        | VDDOT Voltage Level Select<br>VSS = 2.5V/3.3V, VDDOT = 1.5V/1.8V   |

**Table 9: JTAG Interface**

| 88E2010<br>Pin # | 88E2040L<br>Pin # | Pin Name | Pin Type | Description  |
|------------------|-------------------|----------|----------|--|
| K11              | T21               | TDI      | I, PU    | JTAG Data Input  |
| J12              | U21               | TDO      | O        | JTAG Data Output   |
| J11              | V21               | TMS      | I, PU    | JTAG Mode Select   |
| K12              | R21               | TCK      | I, PU    | JTAG Clock   |
| L12              | R22               | TRSTn    | I, PU    | JTAG Reset. TRSTn pin requires a 4.7 kΩ pull-down externally for normal operation. |



Table 10: Test Pins

| 88E2010<br>Pin #                             | 88E2040L<br>Pin #                                    | Pin Name   | Pin<br>Type | Description        |
|--|--|--|-------------|--------------------|
| M3<br>L3<br>--<br>--<br>--<br>--<br>--<br>-- | W2<br>V2<br>W3<br>V3<br>W4<br>V4<br>W5<br>V5         | P0_ATP[0]<br>P0_ATN[0]<br>P0_ATP[1]<br>P0_ATN[1]<br>P0_ATP[2]<br>P0_ATN[2]<br>P0_ATP[3]<br>P0_ATN[3] | O           | Analog Test Port 0 |
| --<br>--<br>--<br>--<br>--<br>--<br>--<br>-- | W10<br>V10<br>W9<br>V9<br>W8<br>V8<br>W7<br>V7       | P1_ATP[0]<br>P1_ATN[0]<br>P1_ATP[1]<br>P1_ATN[1]<br>P1_ATP[2]<br>P1_ATN[2]<br>P1_ATP[3]<br>P1_ATN[3] | O           | Analog Test Port 1 |
| --<br>--<br>--<br>--<br>--<br>--<br>--<br>-- | W12<br>V12<br>W13<br>V13<br>W14<br>V14<br>W15<br>V15 | P2_ATP[0]<br>P2_ATN[0]<br>P2_ATP[1]<br>P2_ATN[1]<br>P2_ATP[2]<br>P2_ATN[2]<br>P2_ATP[3]<br>P2_ATN[3] | O           | Analog Test Port 2 |
| --<br>--<br>--<br>--<br>--<br>--<br>--<br>-- | W20<br>V20<br>W19<br>V19<br>W18<br>V18<br>W17<br>V17 | P3_ATP[0]<br>P3_ATN[0]<br>P3_ATP[1]<br>P3_ATN[1]<br>P3_ATP[2]<br>P3_ATN[2]<br>P3_ATP[3]<br>P3_ATN[3] | O           | Analog Test Port 3 |
| P11<br>N11                                   | AB21<br>AA21   | CHSDACP<br>CHSDACN   | O           | Copper AC Test     |
| A11<br>B11                                   | F19<br>F20   | SHSDACP<br>SHSDACN   | O           | SERDES AC Test     |
| M12  | W22  | CTSTPT   | O           | Copper DC Test     |
| C12  | F22  | STSTPT   | O           | SERDES DC Test     |
| L11<br>M11                                   | U22<br>T22   | TEST_CLKP<br>TEST_CLKN   | I           | Test clock input   |

**Table 10: Test Pins (Continued)**

| 88E2010<br>Pin # | 88E2040L<br>Pin # | Pin Name       | Pin<br>Type | Description  |
|------------------|-------------------|----------------|-------------|--|
| P2<br>N2         | W1<br>V1          | TSTCP<br>TSTCN | O           | Test clock output<br>When using the 50 MHz XTAL option, the (CLK_SEL[1:0] = 00), TSTCP/N output pins must be AC coupled with a 0.1 $\mu$ F capacitor and connected to CLK_P/N input pins on the board (88E2040L devices only). |
| B2               | D12               | TEST           | I, PD       | Test Enable. This pin should be left floating if not used.   |



Table 11: Power and Ground

| 88E2010<br>Pin #     | 88E2040L<br>Pin #        | Pin Name                             | Pin Type | Description  |
|----------------------|--------------------------|--------------------------------------|----------|--|
| F9<br>--<br>--<br>-- | F5<br>F11<br>F12<br>F18  | P0_VHV<br>P1_VHV<br>P2_VHV<br>P3_VHV | Power    | High Voltage Fuse Programming<br><br>These pins must be left floating. |
| L5<br>L7<br>L9<br>-- | N2<br>N3<br>N4<br>N5     | P0_AVDDH                             | Power    | 1.8V or 2.0V analog power  |
| --<br>--<br>--<br>-- | N7<br>N8<br>N9<br>N10    | P1_AVDDH                             | Power    |  |
| --<br>--<br>--<br>-- | N12<br>N13<br>N14<br>N15 | P2_AVDDH                             | Power    |  |
| --<br>--<br>--<br>-- | N17<br>N18<br>N19<br>N20 | P3_AVDDH                             | Power    |  |
| M4<br>M6<br>M8<br>N6 | T2<br>T3<br>T4<br>T5     | P0_AVDDT                             | Power    | 2.5V or 2.3V analog power and center-tap power.                        |
| --<br>--<br>--<br>-- | T7<br>T8<br>T9<br>T10    | P1_AVDDT                             | Power    |  |
| --<br>--<br>--<br>-- | T12<br>T13<br>T14<br>T15 | P2_AVDDT                             | Power    |  |
| --<br>--<br>--<br>-- | T17<br>T18<br>T19<br>T20 | P3_AVDDT                             | Power    |  |



Table 12: Power and Ground (Continued)

| 88E2010<br>Pin #           | 88E2040L<br>Pin #        | Pin Name   | Pin Type | Description   |
|----------------------------|--------------------------|--|----------|---|
| E9<br>M2<br>M10<br>--      | F21<br>W21<br>Y1<br>Y21  | AVDDC  | Power    | 1.5V analog power   |
| K4<br>K6<br>K8<br>--<br>-- | R2<br>R3<br>R4<br>R5     | P0_AVDDL   | Power    | 1.5V analog power   |
| --<br>--<br>--<br>--<br>-- | R7<br>R8<br>R9<br>R10    | P1_AVDDL   | Power    |   |
| --<br>--<br>--<br>--       | R12<br>R13<br>R14<br>R15 | P2_AVDDL   | Power    |   |
| --<br>--<br>--<br>--       | R17<br>R18<br>R19<br>R20 | P3_AVDDL   | Power    |   |
| D9<br>E3                   | D2<br>D4                 | P0_AVDDS   | Power    |   |
| --<br>--                   | D6<br>D8                 | P1_AVDDS   | Power    |   |
| --<br>--                   | D15<br>D17               | P2_AVDDS   | Power    |   |
| --<br>--                   | D19<br>D21               | P3_AVDDS   | Power    |   |
| E4<br>E8<br>--<br>--       | E4<br>E6<br>E15<br>E17   | P0_AVDDR<br>P1_AVDDR<br>P2_AVDDR<br>P3_AVDDR     | Power    | 1.5V analog power   |
| E6<br>--<br>--<br>--       | E2<br>E8<br>E13<br>E19   | P0_VDDR09<br>P1_VDDR09<br>P2_VDDR09<br>P3_VDDR09 | Power    | 0.9V internally regulated power. This pin must be tied to a capacitor. Do not connect this pin to external power. |



Table 12: Power and Ground (Continued)

| 88E2010<br>Pin #                             | 88E2040L<br>Pin #   | Pin Name | Pin Type | Description  |
|--|---|----------|----------|--|
| F5<br>F7<br>G5<br>G7<br>H5<br>H7<br>J5<br>J7 | F7<br>F9<br>F13<br>F15<br>F17<br>G7<br>G9<br>G11<br>G13<br>G15<br>G17<br>H7<br>H9<br>H11<br>H13<br>H15<br>H17<br>J7<br>J9<br>J11<br>J13<br>J15<br>J17<br>K7<br>K9<br>K11<br>K13<br>K15<br>K17<br>L7<br>L9<br>L11<br>L13<br>L15<br>L17 | DVDD     | Power    | Digital power<br>0.8V for C-grade<br>0.88V for I-grade |
| J3   | H5<br>K5  | VDDOL    | Power    | I/O power - LED, CONFIG, CLK_SEL                       |
| G3   | E11   | VDDOM    | Power    | I/O power - MDC, MDIO, INTn, TEST                      |
| G9   | G19<br>J19  | VDDOR    | Power    | I/O power - RESETn, SPI, RCLK0, RCLK1                  |
| J9   | K19   | VDDOT    | Power    | I/O power - JTAG                                       |

Table 12: Power and Ground (Continued)

| 88E2010<br>Pin # | 88E2040L<br>Pin # | Pin Name | Pin Type | Description   |
|------------------|-------------------|----------|----------|---------------|
| A2               | A1                | AVSS     | Power    | Analog Ground |
| A4               | A3                |          |          |               |
| A6               | A5                |          |          |               |
| A8               | A7                |          |          |               |
| A10              | A9                |          |          |               |
| A12              | A14               |          |          |               |
| B4               | A16               |          |          |               |
| B6               | A18               |          |          |               |
| B8               | A20               |          |          |               |
| B10              | A22               |          |          |               |
| C3               | B1                |          |          |               |
| C5               | B3                |          |          |               |
| C7               | B5                |          |          |               |
| C9               | B7                |          |          |               |
| C11              | B9                |          |          |               |
| D5               | B14               |          |          |               |
| D7               | B16               |          |          |               |
| E5               | B18               |          |          |               |
| E7               | B20               |          |          |               |
| K5               | B22               |          |          |               |
| K7               | C2                |          |          |               |
| K9               | C4                |          |          |               |
| L4               | C5                |          |          |               |
| L6               | C6                |          |          |               |
| L8               | C8                |          |          |               |
| L10              | C10               |          |          |               |
| M5               | C13               |          |          |               |
| M7               | C15               |          |          |               |
| M9               | C17               |          |          |               |
| N3               | C18               |          |          |               |
| N10              | C19               |          |          |               |
| P1               | C21               |          |          |               |
| P3               | D5                |          |          |               |
| P6               | D10               |          |          |               |
| P10              | D13               |          |          |               |
| P12              | D18               |          |          |               |
|                  | E1                |          |          |               |
|                  | E3                |          |          |               |
|                  | E5                |          |          |               |
|                  | E7                |          |          |               |
|                  | E9                |          |          |               |
|                  | E10               |          |          |               |
|                  | E14               |          |          |               |
|                  | E16               |          |          |               |
|                  | E18               |          |          |               |
|                  | E20               |          |          |               |
|                  | E22               |          |          |               |
|                  | M1                |          |          |               |
|                  | M5                |          |          |               |
|                  | M6                |          |          |               |
|                  | M7                |          |          |               |
|                  | M8                |          |          |               |



Table 12: Power and Ground (Continued)

| 88E2010<br>Pin # | 88E2040L<br>Pin #  | Pin Name     | Pin<br>Type | Description   |
|------------------|--|--------------|-------------|---------------|
| --               | M9<br>M10<br>M11<br>M12<br>M13<br>M14<br>M15<br>M16<br>M17<br>M18<br>M19<br>N6<br>N11<br>N16<br>P2<br>P3<br>P4<br>P5<br>P6<br>P7<br>P8<br>P9<br>P10<br>P11<br>P12<br>P13<br>P14<br>P15<br>P16<br>P17<br>P18<br>P19<br>P20<br>R6<br>R11<br>R16<br>T6<br>T11<br>T16<br>U2<br>U3<br>U4<br>U5<br>U6<br>U7<br>U8<br>U9<br>U10<br>U11<br>U12<br>U13<br>U14 | AVSS (cont.) | Power       | Analog Ground |

Table 12: Power and Ground (Continued)

| 88E2010<br>Pin # | 88E2040L<br>Pin #  | Pin Name     | Pin<br>Type | Description   |
|------------------|--|--------------|-------------|---------------|
| --               | U15<br>U16<br>U17<br>U18<br>U19<br>U20<br>V6<br>V11<br>V16<br>V22<br>W6<br>W11<br>W16<br>Y2<br>Y5<br>Y6<br>Y7<br>Y10<br>Y11<br>Y12<br>Y15<br>Y16<br>Y17<br>Y20<br>AA1<br>AA6<br>AA11<br>AA16<br>AA22<br>AB1<br>AB6<br>AB11<br>AB16<br>AB22 | AVSS (cont.) | Power       | Analog Ground |



Table 12: Power and Ground (Continued)

| 88E2010<br>Pin #   | 88E2040L<br>Pin #   | Pin Name | Pin Type | Description                                       |
|--|---|----------|----------|---|
| N1   | U1  | AVSSC    | Power    | Analog Ground<br>This must be isolated from AVSS. |
| A1<br>F4<br>F6<br>F8<br>F11<br>G4<br>G6<br>G8<br>H4<br>H6<br>H8<br>J4<br>J6<br>J8<br>J10 | B10<br>B13<br>F6<br>F8<br>F10<br>F14<br>F16<br>G3<br>G6<br>G8<br>G10<br>G12<br>G14<br>G16<br>G18<br>H6<br>H8<br>H10<br>H12<br>H14<br>H16<br>H18<br>H21<br>J2<br>J6<br>J8<br>J10<br>J12<br>J14<br>J16<br>J18<br>K6<br>K8<br>K10<br>K12<br>K14<br>K16<br>K18<br>L3<br>L6<br>L8<br>L10<br>L12<br>L14<br>L16<br>L18<br>L21<br>P21 | VSS      | Power    | Ground  |

## 2.3 Pin Assignment Lists

### 2.3.1 88E2010 Device Pin Assignment List

Table 13: 88E2010 Pin List — Alphabetical by Signal Name

| Pin Number | Pin Name |
|------------|----------|
| L3         | ATN      |
| M3         | ATP      |
| K4         | AVDDL    |
| K6         | AVDDL    |
| K8         | AVDDL    |
| L5         | AVDDH    |
| L7         | AVDDH    |
| L9         | AVDDH    |
| M4         | AVDDT    |
| M6         | AVDDT    |
| M8         | AVDDT    |
| N6         | AVDDT    |
| E9         | AVDDC    |
| M2         | AVDDC    |
| M10        | AVDDC    |
| E4         | AVDDR    |
| E8         | AVDDR    |
| D9         | AVDDS    |
| E3         | AVDDS    |
| A2         | AVSS     |
| A4         | AVSS     |
| A6         | AVSS     |
| A8         | AVSS     |
| A10        | AVSS     |
| A12        | AVSS     |
| B4         | AVSS     |
| B6         | AVSS     |



| Pin Number | Pin Name |
|------------|----------|
| B8         | AVSS     |
| B10        | AVSS     |
| C3         | AVSS     |
| C5         | AVSS     |
| C7         | AVSS     |
| C9         | AVSS     |
| C11        | AVSS     |
| D5         | AVSS     |
| D7         | AVSS     |
| E5         | AVSS     |
| E7         | AVSS     |
| K5         | AVSS     |
| K7         | AVSS     |
| K9         | AVSS     |
| L4         | AVSS     |
| L6         | AVSS     |
| L8         | AVSS     |
| L10        | AVSS     |
| M5         | AVSS     |
| M7         | AVSS     |
| M9         | AVSS     |
| N3         | AVSS     |
| N10        | AVSS     |
| P1         | AVSS     |
| P3         | AVSS     |
| P6         | AVSS     |
| P10        | AVSS     |
| P12        | AVSS     |
| N1         | AVSSC    |
| N11        | CHSDACN  |



---

| Pin Number | Pin Name   |
|------------|------------|
| P11        | CHSDACP    |
| N12        | CIREF      |
| K2         | CLK_SEL[0] |
| L2         | CLK_SEL[1] |
| J1         | CLKN       |
| K1         | CLKP       |
| N7         | CMN        |
| P7         | CMP        |
| H1         | CONFIG[0]  |
| D1         | CONFIG[1]  |
| D2         | CONFIG[2]  |
| E2         | CONFIG[3]  |
| G2         | CONFIG[4]  |
| H2         | CONFIG[5]  |
| D3         | CONFIG[6]  |
| H3         | CONFIG[7]  |
| M12        | CTSTPT     |
| F5         | DVDD       |
| F7         | DVDD       |
| G5         | DVDD       |
| G7         | DVDD       |
| H5         | DVDD       |
| H7         | DVDD       |
| J5         | DVDD       |
| J7         | DVDD       |
| F10        | –          |
| G10        | –          |
| H10        | –          |
| K10        | –          |
| H11        | –          |



| Pin Number | Pin Name           |
|------------|--------------------|
| G12        | –                  |
| C2         | INT <sub>n</sub>   |
| E1         | LED[0]             |
| F1         | LED[1]             |
| G1         | LED[2]             |
| F2         | LED[3]             |
| B1         | MDC                |
| N9         | MDIN[0]            |
| P8         | MDIN[1]            |
| N5         | MDIN[2]            |
| P4         | MDIN[3]            |
| C1         | MDIO               |
| P9         | MDIP[0]            |
| N8         | MDIP[1]            |
| P5         | MDIP[2]            |
| N4         | MDIP[3]            |
| H12        | RCLK0              |
| G11        | RCLK1              |
| D12        | RESET <sub>n</sub> |
| B11        | SHSDACN            |
| A11        | SHSDACP            |
| D10        | SIN[0]             |
| D8         | SIN[1]             |
| D6         | SIN[2]             |
| D4         | SIN[3]             |
| C10        | SIP[0]             |
| C8         | SIP[1]             |
| C6         | SIP[2]             |
| C4         | SIP[3]             |
| B12        | SIREF              |

---

| Pin Number | Pin Name              |
|------------|-----------------------|
| B9         | SON[0]                |
| B7         | SON[1]                |
| B5         | SON[2]                |
| B3         | SON[3]                |
| A9         | SOP[0]                |
| A7         | SOP[1]                |
| A5         | SOP[2]                |
| A3         | SOP[3]                |
| F12        | SPI_CLK               |
| E12        | SPI_MISO              |
| E11        | SPI_MOSI              |
| D11        | SPI_SS <sub>n</sub>   |
| C12        | STSTPT                |
| K12        | TCK                   |
| K11        | TDI                   |
| J12        | TDO                   |
| B2         | TEST                  |
| M11        | TEST_CLK <sub>N</sub> |
| L11        | TEST_CLK <sub>P</sub> |
| J11        | TMS                   |
| L12        | TRST <sub>n</sub>     |
| N2         | TSTCN                 |
| P2         | TSTCP                 |
| J2         | VDDCTRL               |
| J3         | VDDOL                 |
| G3         | VDDOM                 |
| G9         | VDDOR                 |
| J9         | VDDOT                 |
| E6         | VDDR09                |
| F9         | VHV                   |



| Pin Number | Pin Name |
|------------|----------|
| K3         | VSEL_L   |
| F3         | VSEL_M   |
| E10        | VSEL_R   |
| H9         | VSEL_T   |
| A1         | VSS      |
| F4         | VSS      |
| F6         | VSS      |
| F8         | VSS      |
| F11        | VSS      |
| G4         | VSS      |
| G6         | VSS      |
| G8         | VSS      |
| H4         | VSS      |
| H6         | VSS      |
| H8         | VSS      |
| J4         | VSS      |
| J6         | VSS      |
| J8         | VSS      |
| J10        | VSS      |
| M1         | XTAL1    |
| L1         | XTAL2    |

## 2.3.2 88E2040L Device Pin Assignment List

Table 14: 88E2040L Pin List — Alphabetical by Signal Name

| Pin Number | Pin Name |
|------------|----------|
| F21        | AVDDC    |
| W21        | AVDDC    |
| Y1         | AVDDC    |
| Y21        | AVDDC    |
| A1         | AVSS     |
| A3         | AVSS     |
| A5         | AVSS     |
| A7         | AVSS     |
| A9         | AVSS     |
| A14        | AVSS     |
| A16        | AVSS     |
| A18        | AVSS     |
| A20        | AVSS     |
| A22        | AVSS     |
| B1         | AVSS     |
| B3         | AVSS     |
| B5         | AVSS     |
| B7         | AVSS     |
| B9         | AVSS     |
| B14        | AVSS     |
| B16        | AVSS     |
| B18        | AVSS     |
| B20        | AVSS     |
| B22        | AVSS     |
| C2         | AVSS     |
| C4         | AVSS     |
| C5         | AVSS     |
| C6         | AVSS     |



| Pin Number | Pin Name |
|------------|----------|
| C8         | AVSS     |
| C10        | AVSS     |
| C13        | AVSS     |
| C15        | AVSS     |
| C17        | AVSS     |
| C18        | AVSS     |
| C19        | AVSS     |
| C21        | AVSS     |
| D5         | AVSS     |
| D10        | AVSS     |
| D13        | AVSS     |
| D18        | AVSS     |
| E1         | AVSS     |
| E3         | AVSS     |
| E5         | AVSS     |
| E7         | AVSS     |
| E9         | AVSS     |
| E10        | AVSS     |
| E14        | AVSS     |
| E16        | AVSS     |
| E18        | AVSS     |
| E20        | AVSS     |
| E22        | AVSS     |
| M1         | AVSS     |
| M5         | AVSS     |
| M6         | AVSS     |
| M7         | AVSS     |
| M8         | AVSS     |
| M9         | AVSS     |
| M10        | AVSS     |

| <b>Pin Number</b> | <b>Pin Name</b> |
|-------------------|-----------------|
| M11               | AVSS            |
| M12               | AVSS            |
| M13               | AVSS            |
| M14               | AVSS            |
| M15               | AVSS            |
| M16               | AVSS            |
| M17               | AVSS            |
| M18               | AVSS            |
| M19               | AVSS            |
| N6                | AVSS            |
| N11               | AVSS            |
| N16               | AVSS            |
| P2                | AVSS            |
| P3                | AVSS            |
| P4                | AVSS            |
| P5                | AVSS            |
| P6                | AVSS            |
| P7                | AVSS            |
| P8                | AVSS            |
| P9                | AVSS            |
| P10               | AVSS            |
| P11               | AVSS            |
| P12               | AVSS            |
| P13               | AVSS            |
| P14               | AVSS            |
| P15               | AVSS            |
| P16               | AVSS            |
| P17               | AVSS            |
| P18               | AVSS            |
| P19               | AVSS            |



| Pin Number | Pin Name |
|------------|----------|
| P20        | AVSS     |
| R6         | AVSS     |
| R11        | AVSS     |
| R16        | AVSS     |
| T6         | AVSS     |
| T11        | AVSS     |
| T16        | AVSS     |
| U2         | AVSS     |
| U3         | AVSS     |
| U4         | AVSS     |
| U5         | AVSS     |
| U6         | AVSS     |
| U7         | AVSS     |
| U8         | AVSS     |
| U9         | AVSS     |
| U10        | AVSS     |
| U11        | AVSS     |
| U12        | AVSS     |
| U13        | AVSS     |
| U14        | AVSS     |
| U15        | AVSS     |
| U16        | AVSS     |
| U17        | AVSS     |
| U18        | AVSS     |
| U19        | AVSS     |
| U20        | AVSS     |
| V6         | AVSS     |
| V11        | AVSS     |
| V16        | AVSS     |
| V22        | AVSS     |



---

| Pin Number | Pin Name   |
|------------|------------|
| W6         | AVSS       |
| W11        | AVSS       |
| W16        | AVSS       |
| Y2         | AVSS       |
| Y5         | AVSS       |
| Y6         | AVSS       |
| Y7         | AVSS       |
| Y10        | AVSS       |
| Y11        | AVSS       |
| Y12        | AVSS       |
| Y15        | AVSS       |
| Y16        | AVSS       |
| Y17        | AVSS       |
| Y20        | AVSS       |
| AA1        | AVSS       |
| AA6        | AVSS       |
| AA11       | AVSS       |
| AA16       | AVSS       |
| AA22       | AVSS       |
| AB1        | AVSS       |
| AB6        | AVSS       |
| AB11       | AVSS       |
| AB16       | AVSS       |
| AB22       | AVSS       |
| U1         | AVSSC      |
| AA21       | CHSDACN    |
| AB21       | CHSDACP    |
| Y22        | CIREF      |
| M3         | CLK_SEL[0] |
| M4         | CLK_SEL[1] |



| Pin Number | Pin Name  |
|------------|-----------|
| N1         | CLKN      |
| P1         | CLKP      |
| L1         | CONFIG[0] |
| L2         | CONFIG[1] |
| M2         | CONFIG[2] |
| L4         | CONFIG[3] |
| H1         | CONFIG[4] |
| H4         | CONFIG[5] |
| J5         | CONFIG[6] |
| G5         | CONFIG[7] |
| W22        | CTSTPT    |
| F7         | DVDD      |
| F9         | DVDD      |
| F13        | DVDD      |
| F15        | DVDD      |
| F17        | DVDD      |
| G7         | DVDD      |
| G9         | DVDD      |
| G11        | DVDD      |
| G13        | DVDD      |
| G15        | DVDD      |
| G17        | DVDD      |
| H7         | DVDD      |
| H9         | DVDD      |
| H11        | DVDD      |
| H13        | DVDD      |
| H15        | DVDD      |
| H17        | DVDD      |
| J7         | DVDD      |
| J9         | DVDD      |

---

| Pin Number | Pin Name  |
|------------|-----------|
| J11        | DVDD      |
| J13        | DVDD      |
| J15        | DVDD      |
| J17        | DVDD      |
| K7         | DVDD      |
| K9         | DVDD      |
| K11        | DVDD      |
| K13        | DVDD      |
| K15        | DVDD      |
| K17        | DVDD      |
| L7         | DVDD      |
| L9         | DVDD      |
| L11        | DVDD      |
| L13        | DVDD      |
| L15        | DVDD      |
| L17        | DVDD      |
| D11        | INTn      |
| B11        | MDC[0]    |
| A11        | MDC[1]    |
| A12        | MDC[2]    |
| B12        | MDC[3]    |
| C11        | MDIO[0]   |
| A10        | MDIO[1]   |
| A13        | MDIO[2]   |
| C12        | MDIO[3]   |
| V2         | P0_ATN[0] |
| V3         | P0_ATN[1] |
| V4         | P0_ATN[2] |
| V5         | P0_ATN[3] |
| W2         | P0_ATP[0] |



| <b>Pin Number</b> | <b>Pin Name</b> |
|-------------------|-----------------|
| W3                | P0_ATP[1]       |
| W4                | P0_ATP[2]       |
| W5                | P0_ATP[3]       |
| R2                | P0_AVDDL        |
| R3                | P0_AVDDL        |
| R4                | P0_AVDDL        |
| R5                | P0_AVDDL        |
| N2                | P0_AVDDH        |
| N3                | P0_AVDDH        |
| N4                | P0_AVDDH        |
| N5                | P0_AVDDH        |
| T2                | P0_AVDDT        |
| T3                | P0_AVDDT        |
| T4                | P0_AVDDT        |
| T5                | P0_AVDDT        |
| E4                | P0_AVDDR        |
| D2                | P0_AVDDS        |
| D4                | P0_AVDDS        |
| Y3                | P0_CMN          |
| Y4                | P0_CMP          |
| L22               | P0_GPIO[0]      |
| L20               | P0_GPIO[1]      |
| H22               | P0_GPIO[2]      |
| K1                | P0_LED[0]       |
| K2                | P0_LED[1]       |
| K3                | P0_LED[2]       |
| K4                | P0_LED[3]       |
| AA2               | P0_MDIN[0]      |
| AA3               | P0_MDIN[1]      |
| AA4               | P0_MDIN[2]      |

| Pin Number | Pin Name   |
|------------|------------|
| AA5        | P0_MDIN[3] |
| AB2        | P0_MDIP[0] |
| AB3        | P0_MDIP[1] |
| AB4        | P0_MDIP[2] |
| AB5        | P0_MDIP[3] |
| D1         | P0_SIN[0]  |
| D3         | P0_SIN[1]  |
| C1         | P0_SIP[0]  |
| C3         | P0_SIP[1]  |
| B2         | P0_SON[0]  |
| B4         | P0_SON[1]  |
| A2         | P0_SOP[0]  |
| A4         | P0_SOP[1]  |
| E2         | P0_VDDR09  |
| F5         | P0_VHV     |
| V10        | P1_ATN[0]  |
| V9         | P1_ATN[1]  |
| V8         | P1_ATN[2]  |
| V7         | P1_ATN[3]  |
| W10        | P1_ATP[0]  |
| W9         | P1_ATP[1]  |
| W8         | P1_ATP[2]  |
| W7         | P1_ATP[3]  |
| R7         | P1_AVDDL   |
| R8         | P1_AVDDL   |
| R9         | P1_AVDDL   |
| R10        | P1_AVDDL   |
| N7         | P1_AVDDH   |
| N8         | P1_AVDDH   |
| N9         | P1_AVDDH   |



| <b>Pin Number</b> | <b>Pin Name</b> |
|-------------------|-----------------|
| N10               | P1_AVDDH        |
| T7                | P1_AVDDT        |
| T8                | P1_AVDDT        |
| T9                | P1_AVDDT        |
| T10               | P1_AVDDT        |
| E6                | P1_AVDDR        |
| D6                | P1_AVDDS        |
| D8                | P1_AVDDS        |
| Y9                | P1_CMN          |
| Y8                | P1_CMP          |
| M22               | P1_GPIO[0]      |
| M20               | P1_GPIO[1]      |
| H20               | P1_GPIO[2]      |
| J1                | P1_LED[0]       |
| J3                | P1_LED[1]       |
| H3                | P1_LED[2]       |
| J4                | P1_LED[3]       |
| AA10              | P1_MDIN[0]      |
| AA9               | P1_MDIN[1]      |
| AA8               | P1_MDIN[2]      |
| AA7               | P1_MDIN[3]      |
| AB10              | P1_MDIP[0]      |
| AB9               | P1_MDIP[1]      |
| AB8               | P1_MDIP[2]      |
| AB7               | P1_MDIP[3]      |
| D9                | P1_SIN[0]       |
| D7                | P1_SIN[1]       |
| C9                | P1_SIP[0]       |
| C7                | P1_SIP[1]       |
| B8                | P1_SON[0]       |

| Pin Number | Pin Name  |
|------------|-----------|
| B6         | P1_SON[1] |
| A8         | P1_SOP[0] |
| A6         | P1_SOP[1] |
| E8         | P1_VDDR09 |
| F11        | P1_VHV    |
| V12        | P2_ATN[0] |
| V13        | P2_ATN[1] |
| V14        | P2_ATN[2] |
| V15        | P2_ATN[3] |
| W12        | P2_ATP[0] |
| W13        | P2_ATP[1] |
| W14        | P2_ATP[2] |
| W15        | P2_ATP[3] |
| R12        | P2_AVDDL  |
| R13        | P2_AVDDL  |
| R14        | P2_AVDDL  |
| R15        | P2_AVDDL  |
| N12        | P2_AVDDH  |
| N13        | P2_AVDDH  |
| N14        | P2_AVDDH  |
| N15        | P2_AVDDH  |
| T12        | P2_AVDDT  |
| T13        | P2_AVDDT  |
| T14        | P2_AVDDT  |
| T15        | P2_AVDDT  |
| E15        | P2_AVDDR  |
| D15        | P2_AVDDS  |
| D17        | P2_AVDDS  |
| Y13        | P2_CMN    |
| Y14        | P2_CMP    |



| <b>Pin Number</b> | <b>Pin Name</b> |
|-------------------|-----------------|
| N22               | P2_GPIO[0]      |
| M21               | P2_GPIO[1]      |
| J21               | P2_GPIO[2]      |
| G1                | P2_LED[0]       |
| G2                | P2_LED[1]       |
| H2                | P2_LED[2]       |
| G4                | P2_LED[3]       |
| AA12              | P2_MDIN[0]      |
| AA13              | P2_MDIN[1]      |
| AA14              | P2_MDIN[2]      |
| AA15              | P2_MDIN[3]      |
| AB12              | P2_MDIP[0]      |
| AB13              | P2_MDIP[1]      |
| AB14              | P2_MDIP[2]      |
| AB15              | P2_MDIP[3]      |
| D14               | P2_SIN[0]       |
| D16               | P2_SIN[1]       |
| C14               | P2_SIP[0]       |
| C16               | P2_SIP[1]       |
| B15               | P2_SON[0]       |
| B17               | P2_SON[1]       |
| A15               | P2_SOP[0]       |
| A17               | P2_SOP[1]       |
| E13               | P2_VDDR09       |
| F12               | P2_VHV          |
| V20               | P3_ATN[0]       |
| V19               | P3_ATN[1]       |
| V18               | P3_ATN[2]       |
| V17               | P3_ATN[3]       |
| W20               | P3_ATP[0]       |



---

| Pin Number | Pin Name   |
|------------|------------|
| W19        | P3_ATP[1]  |
| W18        | P3_ATP[2]  |
| W17        | P3_ATP[3]  |
| R17        | P3_AVDDL   |
| R18        | P3_AVDDL   |
| R19        | P3_AVDDL   |
| R20        | P3_AVDDL   |
| N17        | P3_AVDDH   |
| N18        | P3_AVDDH   |
| N19        | P3_AVDDH   |
| N20        | P3_AVDDH   |
| T17        | P3_AVDDT   |
| T18        | P3_AVDDT   |
| T19        | P3_AVDDT   |
| T20        | P3_AVDDT   |
| E17        | P3_AVDDR   |
| D19        | P3_AVDDS   |
| D21        | P3_AVDDS   |
| Y19        | P3_CMN     |
| Y18        | P3_CMP     |
| P22        | P3_GPIO[0] |
| N21        | P3_GPIO[1] |
| K21        | P3_GPIO[2] |
| F1         | P3_LED[0]  |
| F2         | P3_LED[1]  |
| F3         | P3_LED[2]  |
| F4         | P3_LED[3]  |
| AA20       | P3_MDIN[0] |
| AA19       | P3_MDIN[1] |
| AA18       | P3_MDIN[2] |



| <b>Pin Number</b> | <b>Pin Name</b> |
|-------------------|-----------------|
| AA17              | P3_MDIN[3]      |
| AB20              | P3_MDIP[0]      |
| AB19              | P3_MDIP[1]      |
| AB18              | P3_MDIP[2]      |
| AB17              | P3_MDIP[3]      |
| D22               | P3_SIN[0]       |
| D20               | P3_SIN[1]       |
| C22               | P3_SIP[0]       |
| C20               | P3_SIP[1]       |
| B21               | P3_SON[0]       |
| B19               | P3_SON[1]       |
| A21               | P3_SOP[0]       |
| A19               | P3_SOP[1]       |
| E19               | P3_VDDR09       |
| F18               | P3_VHV          |
| K22               | RCLK0           |
| J22               | RCLK1           |
| G22               | RESETn          |
| F20               | SHSDACN         |
| F19               | SHSDACP         |
| E21               | SIREF           |
| K20               | SPI_CLK         |
| J20               | SPI_MISO        |
| G20               | SPI_MOSI        |
| G21               | SPI_SSn         |
| F22               | STSTPT          |
| R21               | TCK             |
| T21               | TDI             |
| U21               | TDO             |
| D12               | TEST            |

---

| Pin Number | Pin Name  |
|------------|-----------|
| T22        | TEST_CLKN |
| U22        | TEST_CLKP |
| V21        | TMS       |
| R22        | TRSTn     |
| V1         | TSTCN     |
| W1         | TSTCP     |
| H5         | VDDOL     |
| K5         | VDDOL     |
| E11        | VDDOM     |
| G19        | VDDOR     |
| J19        | VDDOR     |
| K19        | VDDOT     |
| L5         | VSEL_L    |
| E12        | VSEL_M    |
| H19        | VSEL_R    |
| L19        | VSEL_T    |
| B10        | VSS       |
| B13        | VSS       |
| F6         | VSS       |
| F8         | VSS       |
| F10        | VSS       |
| F14        | VSS       |
| F16        | VSS       |
| G3         | VSS       |
| G6         | VSS       |
| G8         | VSS       |
| G10        | VSS       |
| G12        | VSS       |
| G14        | VSS       |
| G16        | VSS       |



| Pin Number | Pin Name |
|------------|----------|
| G18        | VSS      |
| H6         | VSS      |
| H8         | VSS      |
| H10        | VSS      |
| H12        | VSS      |
| H14        | VSS      |
| H16        | VSS      |
| H18        | VSS      |
| H21        | VSS      |
| J2         | VSS      |
| J6         | VSS      |
| J8         | VSS      |
| J10        | VSS      |
| J12        | VSS      |
| J14        | VSS      |
| J16        | VSS      |
| J18        | VSS      |
| K6         | VSS      |
| K8         | VSS      |
| K10        | VSS      |
| K12        | VSS      |
| K14        | VSS      |
| K16        | VSS      |
| K18        | VSS      |
| L3         | VSS      |
| L6         | VSS      |
| L8         | VSS      |
| L10        | VSS      |
| L12        | VSS      |
| L14        | VSS      |

| <b>Pin Number</b> | <b>Pin Name</b> |
|-------------------|-----------------|
| L16               | VSS             |
| L18               | VSS             |
| L21               | VSS             |
| P21               | VSS             |
| T1                | XTAL1           |
| R1                | XTAL2           |



# 3

## Functional Description

This section describes the chip-level functionality.

### 3.1 Buffering

Packets may flow through some buffering. Buffering will occur for a variety of all the reasons described in this section.

#### 3.1.1 EEE Buffering

EEE PHY functionality to operate correctly, an EEE-compliant MAC is required to control the PHY as when to enter and exit the low power idle (LPI) state and buffer packets to allow the PHY adequate time to exit the low power idle state. The PHY should beset to transparent (slave) EEE mode when operating with an EEE-compliant MAC (register 1.C033.0 = 0).

The device is able to support non-EEE compliant MACs by enabling the internal EEE buffering by setting register 1.C033.0 to 1. EEE buffering is automatically disabled when the device or its link partner is not capable of EEE operation.

When the EEE buffer is empty for the amount of time specified by registers 1.C033.15:8, 31.F004.7:0, 31.F004.15:8 for 10 Gbps, 1000 Mbps, and 100 Mbps speeds, respectively (in units of 1 microsecond), the buffer will indicate to the PHY that it wishes to enter the LPI state.

When the EEE buffer is not empty it will indicate to the PHY that it must exit the LPI state. The EEE buffer ensures that no packets are lost by the PHY during the transition from LPI state to normal mode of operation. When the media interface exits the LPI state, the data in the buffer is then released and transmitted to the line. The amount of time the packet is held in the buffer prior to release can be programmed via registers 31.F005.15:8, 31.F006.7:0, and 31.F006.15:8 for 10 Gbps, 1000 Mbps, and 100 Mbps speeds, respectively. The unit is in microseconds. The minimum IPG between packets as set in 31.F005.7:0 will be used to separate packets until the EEE buffer is fully drained.

### 3.2 Link Interrupt

When the MACs are not bypassed, all local and remote faults received on the line or host will be terminated by the MAC. For example, if a local fault is received on the line, then the MAC terminates the local fault and never passes it upstream to the host. The MAC will transmit a remote fault back to the line.

## 3.3 Loopback

The T, X, and H Units has the ability to perform MAC loopback and line loopback as shown in [Figure 5](#). Each unit can only be in MAC loopback or line loopback at any given time. If MAC loopback is engaged, then loopback speed depends upon the media link speed. If the media link is down, then the MAC interface speed is dependent upon the setting in 31.F000.7:6, Default MAC Interface Speed. A deep line loopback must not be enabled at the same time as a MAC loopback or a closed internal bus loop will be created.

**Table 15: Loopback Control**

| Loopback Point | Register                            | Function  | Setting   |
|----------------|-------------------------------------|---|---|
| A              | 3.0000.14                           | T Unit Deep MAC Loopback                          | 1 = Loopback<br>0 = Normal operation  |
| B              | 3.1000.14<br>3.2000.14              | X Unit Deep MAC Loopback                          | 1 = Loopback<br>0 = Normal operation  |
| C              | 4.0000.14<br>4.1000.14<br>4.2000.14 | H Unit Deep Line Loopback                         | 1 = Loopback<br>0 = Normal operation  |
| D              | 3.8002.5                            | T Unit Shallow Line Loopback for 1000/100/10 mode | 1 = Enable Line Loopback<br>0 = Normal operation  |
| E              | 1.C000.11                           | T Unit Shallow Line Loopback for 5G/2.5G mode     | 1 = Enable Line Loopback<br>0 = Normal operation  |
| F              | 3.F003.12                           | X Unit Shallow Line Loopback                      | 1 = Enable Line Loopback<br>0 = Normal operation  |
| G              | 4.F003.12                           | H Unit Shallow MAC Loopback                       | 1 = Enable Line Loopback<br>0 = Normal operation  |
| –              | 31.F000.7:6                         | Default MAC Interface Speed                       | This is the MAC Interface Speed during Link down.<br>00 = 10 Mbps<br>01 = 100 Mbps<br>10 = 1000 Mbps<br>11 = 10 Gbps          |
| –              | 31.F0A8.1:0                         | Device Max Speed Limit Control                    | This controls the link down max speed.<br>00 = 10 Gbps<br>10 = 5 Gbps<br>11 = 2.5 Gbps<br>Port soft reset should be followed. |



Figure 5: Loopback Paths

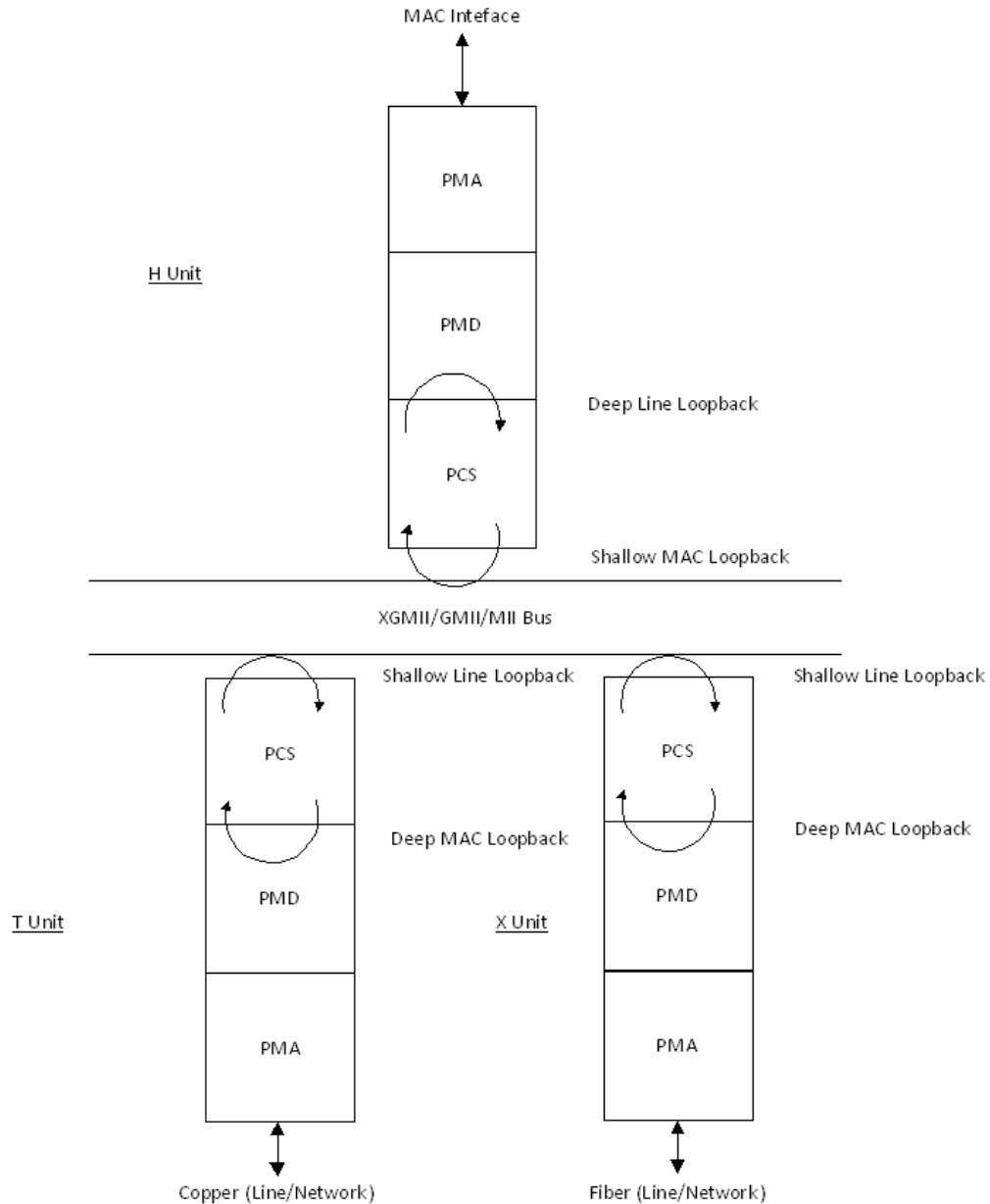

### 3.3.1 MAC Loopback

MAC loopback is defined as taking data from the MAC interface and transmitting that data back towards the MAC interface. For the loopback to occur, the unit must have control of the XGMII bus that it is outputting on, that is, that unit must have control of the data path.

If the link is down, then the loopback speed will be determined by register 31.F000.7:6 and 31.F0A8.1:0. Only host shallow MAC loopback is supported when the media link is down.



### 3.3.2 Line Loopback

Line loopback is defined to be looping the data that is received on the network interface and transmitting that data back onto the network interface.

The speed of the loopback is determined by the active link speed.

## 3.4 Configuration and Resets

The device can be configured in the following ways:

- Hardware configuration strap options
- MDC/MDIO register access

All hardware configuration options can be overwritten via the other methods except PHYADR and MDIO.

This section will discuss the hardware configuration.

### 3.4.1 Hardware and Software Resets

RESETn is the hardware reset pin for the entire chip. To ensure that the stopping of the hardware configuration is correct, it is required that upon system power-up, a reset signal be applied to RESETn or the RESETn pin be held low until all the power rails are settled down.

In addition to the hardware reset pin (RESETn), there are several software reset bits that reset various parts of the chip.

- A hardware reset will reset the entire chip and initialize all the registers to their hardware reset default.
- A software reset has a similar effect on the affected units as a hardware reset except all Retain-type of will hold their value, and the Update-type registers will have the previously written values take effect.

Register 31.F001.14 is a software bit that emulates the hardware reset. Setting the bit to 1 will reset the entire chip (all ports) as if the RESETn pin is asserted. All ports have register 31.F001.14; however, special care should be taken when selecting the specific port number to achieve entire chip reset. The applicable register in Port 3 (88E2040L) and Port 0 (88E2010) should be programmed. When triggered, registers are not accessible through the MDIO until the chip reset completes.

Setting register 31.F001.15 to 1 software resets the entire port except for the T Unit. The T Unit will briefly power down and Auto-Negotiation will restart.

Setting registers 31.F001.13, 1.0000.15, 3.0000.15, or 7.0000.15 to 1 software resets the T Unit only.

Setting registers 4.0000.15, 4.1000.15, or 4.2000.15 to 1 software resets the H Unit only.

### 3.4.2 Hardware Configuration

After the deassertion of RESETn the device will be hardware configured through the CONFIG[7:0] pins. Each pin is used to configure 3 bits. The 3-bit value is set depending on which LED pin or static level is connected to the CONFIG pins at the deassertion of hardware reset.

The three configuration bits per pin mapping for the 88E2010 device is shown in [Table 16](#).

The three bit mapping for the 88E2010 device during hardware configuration is shown in [Table 17](#).

**Table 16: 88E2010 Device Configuration Mapping**

| Pin Test  | Bit 2        | Bit 1        | Bit 2        |
|-----------|--------------|--------------|--------------|
| CONFIG[0] | PHYAD[4]     | PHYAD[3]     | PHYAD[2]     |
| CONFIG[1] | ANEG_MS      | PHYAD[1]     | PDSTATE      |
| CONFIG[2] | ANEG_SPD[2]  | ANEG_SPD[1]  | ANEG_SPD[0]  |
| CONFIG[3] | MACTYPE[2]   | MACTYPE[1]   | MACTYPE[0]   |
| CONFIG[4] | MEDIATYPE[2] | MEDIATYPE[1] | MEDIATYPE[0] |
| CONFIG[5] | SPI_CONFIG   | RESERVED     | RESERVED     |
| CONFIG[7] | FACTORY_TEST | RESERVED     | RESERVED     |

**Table 17: 88E2010 Three Bit Mapping**

| Pin      | Bit 2 |
|----------|-------|
| VSS      | 000   |
| LED[0]   | 001   |
| LED[1]   | 010   |
| LED[2]   | 011   |
| LED[3]   | 100   |
| Reserved | 101   |
| Reserved | 110   |
| VDDO     | 111   |

The three configuration bits per pin mapping for the 88E2040L device is shown in [Table 18](#).

The three bit mapping for the 88E2040L device during hardware configuration is shown in [Table 19](#).

**Table 18: 88E2040L Device Configuration Mapping**

| Pin       | Bit 2        | Bit 1        | Bit 0        |
|-----------|--------------|--------------|--------------|
| CONFIG[0] | PHYAD[4]     | PHYAD[3]     | PHYAD[2]     |
| CONFIG[1] | ANEG_MS      | RESERVED     | PDSTATE      |
| CONFIG[2] | ANEG_SPD[2]  | ANEG_SPD[1]  | ANEG_SPD[0]  |
| CONFIG[3] | MACTYPE[2]   | MACTYPE[1]   | MACTYPE[0]   |
| CONFIG[4] | MEDIATYPE[2] | MEDIATYPE[1] | MEDIATYPE[0] |
| CONFIG[5] | SPI_CONFIG   | RESERVED     | RESERVED     |
| CONFIG[7] | FACTORY_TEST | MDIO[1]      | MDIO[0]      |

**Table 19: 88E2040L Device Three Bit Mapping**

| Pin       | Bit 2:0 |
|-----------|---------|
| VSS       | 000     |
| P3_LED[0] | 001     |
| P3_LED[1] | 010     |
| P2_LED[0] | 011     |
| P2_LED[1] | 100     |
| P1_LED[0] | 101     |
| P1_LED[1] | 110     |
| VDDO      | 111     |

The configuration bit definition is shown in [Table 20](#).

**Table 20: Configuration Bit Definition**

| Bits                    | Definition  | Description  |
|-------------------------|---|--|
| PHYAD[4:0]              | PHY Address   | 88E2040L<br>PHYAD[1:0] is hardcoded as a function of REV_PHYAD.  |
| REV_PHYAD               | 88E2040L - Reverse PHYAD[1:0] order<br>88E2010 - N/A  | 88E2040L<br>PHYAD[1:0] corresponds to the following:<br>0 = 00 - Port 0<br>01 - Port 1<br>10 - Port 2<br>11 - Port 3<br>1 = 00 - Port 3<br>01 - Port 2<br>10 - Port 1<br>11 - Port 0 |
| MDIO[1:0]<br>(88E2040L) | This determines whether the four ports are accessed from a 1 MDIO, 2 ports per MDIO, or 1 MDIO per port.<br>00 = MDC[2]/MDIO[2] Access on all four ports<br>01 = MDC[1]/MDIO[1] Accesses Port 0 and Port 1<br>MDC[2]/MDIO[2] Accesses Port 2 and Port 3<br>10 = MDC[0]/MDIO[0] Accesses Port 0<br>MDC[1]/MDIO[1] Accesses Port 1<br>MDC[2]/MDIO[2] Accesses Port 2<br>MDC[3]/MDIO[3] Accesses Port 3<br>11 = Reserved | None   |



Table 20: Configuration Bit Definition (Continued)

| Bits                       | Definition   | Description                                |
|----------------------------|--|--|
| MACTYPE[2:0]<br>(88E2040L) | 000 = Reserved<br>001 = Reserved<br>010 = Reserved<br>011 = Reserved<br>100 = 5GBASE-R/2500BASE-X/SGMII<br>Auto-Negotiation On<br>101 = 5GBASE-R/2500BASE-X/SGMII<br>Auto-Negotiation Off<br>110 = Reserved<br>111 = Reserved  | C Unit<br>Host interface mode for 88E2040L |
| MACTYPE[2:0]<br>(88E2010)  | 000 = Reserved<br>001 = Reserved<br>010 = Reserved<br>011 = 5GBASE-R/2500BASE-X/SGMII<br>Auto-Negotiation On<br>100 = 5GBASE-R/2500BASE-X/SGMII<br>Auto-Negotiation On<br>101 = 5GBASE-R/2500BASE-X/SGMII SGMII<br>Auto-Negotiation Off<br>110 = Reserved<br>111 = Reserved  | C Unit<br>Host interface mode for 88E2010  |
| MEDIATYPE[2:0]             | 000 = Copper Only<br>001-111 = RESERVED  | C Unit<br>Line-side interface              |
| PDSTATE                    | 0 = Start In Power Up State<br>1 = Start In Power Down State   | T Unit<br>Copper power down state          |
| ANEG_MS                    | 0 = Prefer Slave<br>1 = Prefer Master  | T Unit<br>Master and slave configuration   |
| FACTORY_TEST               | Factory Test Mode<br>0 = Normal mode (default)<br>1 = Test Mode (reserved for Marvell)   | None                                       |
| ANEG_SPD[2:0]              | This sets the default for speed advertisement during Auto-Negotiation.<br>000 = Reserved<br>001 = 5G, 2.5G, 1000 Mbps Full<br>010 = 5G, 2.5G, 1000 Mbps Full, 100 Mbps Full<br>011 = 5G, 2.5G, 1000 Mbps Full, 100 Mbps Full, 10 Mbps Full<br>100 = 5G, 2.5G, 1000 Mbps Full, 100 Mbps Full/Half<br>101 = 5G, 2.5G, 1000 Mbps Full, 100 Mbps Full/Half, 10 Mbps Full/Half<br>110 = 5G, 2.5G, 1000 Mbps Full/Half, 100 Mbps Full/Half<br>111 = 5G, 2.5G, 1000 Mbps Full/Half, 100 Mbps Full/Half, 10 Mbps Full/Half | –  |

Table 20: Configuration Bit Definition (Continued)

| Bits       | Definition | Description   |
|------------|------------|---|
| SPI_CONFIG | –          | C Unit<br>31.F008.5 <= SPI_CONFIG<br>This determines whether the embedded processor loads the firmware image from flash or waits for the image to be downloaded via MDIO.<br>0 = Download code via SPI.<br>1 = Wait for download via MDIO.<br>To override this configuration, change 31.F008.5 and then perform a T Unit hardware reset using 31.F001.12. |



### 3.4.3 Reference Clock Selection

CLK\_SEL[1:0] selects which the type and speed of the reference clock input as shown in [Table 21](#). CLK\_SEL must be stable and the selected clock toggling prior to de-assertion of RESETn. CLK\_SEL must not change value for the duration of device operation.

**Table 21: CLK\_SEL[1:0] Selection**

| CLK_SEL[1:0] | XTAL1/XTAL2 | CLKP/CLKN  |
|--------------|-------------|------------|
| 00           | 50 MHz      | Floating   |
| 01           | GND         | 50 MHz     |
| 10           | GND         | 156.25 MHz |
| 11           | Reserved    | Reserved   |



**Note**

50 MHz crystal operation is only supported for commercial-grade devices.

### 3.5 MDC/MDIO Register Access

The management interface provides access to the internal registers via the MDC and MDIO pins and is compliant with IEEE 802.3 Clause 45. MDC is the management data clock input and it can run from DC to a maximum continuous rate of 12.5 MHz. At high MDIO fanouts, the maximum rate may be decreased depending on the output loading. MDIO is the management data input/output and is a bi-directional signal that runs synchronously to MDC.

The MDIO does not require a pull-up resistor. If another open-drain device driving MDIO requires a pull-up resistor, then it should drive or be pulled up to the same voltage value as the VDDOM rail.

The PHY address is configured during the hardware reset sequence. Refer to [Section 3.4, Configuration and Resets](#), on page 65 for information on how to configure PHY addresses.

Typical read and write operations on the management interface are shown in [Figure 6](#) and [Figure 7](#). The MDIO interface supports preamble suppression operation by default. Between subsequence MDIO access sequences, there must be at least 1 IDLE MDC cycle (MDIO driven high). So the minimum MDC clock cycle for a MDIO operation will 33 cycles. The start of a MDIO operation is marked by the insertion of two MDC cycle with MDIO driven to zero as this will mark the start of frame (ST) pattern as defined in IEEE 802.3 standard. All the required serial management registers are implemented as well as several optional registers. A description of the registers can be found in the register description.

**Figure 6: Typical MDC/MDIO Read Operation**

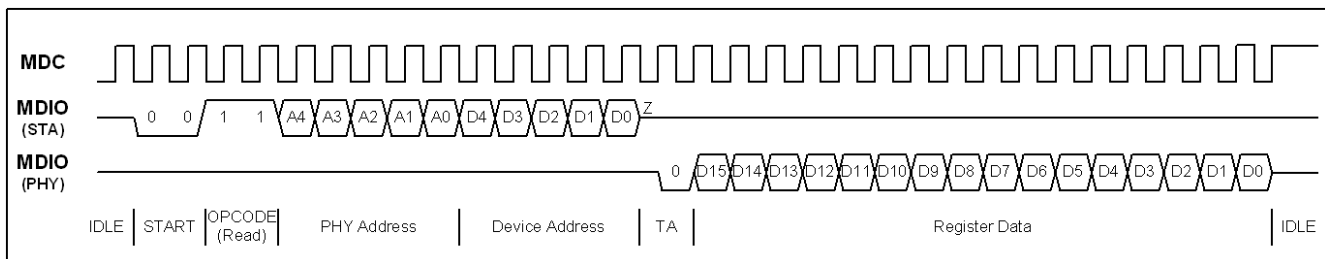

**Figure 7: Typical MDC/MDIO Write Operation**

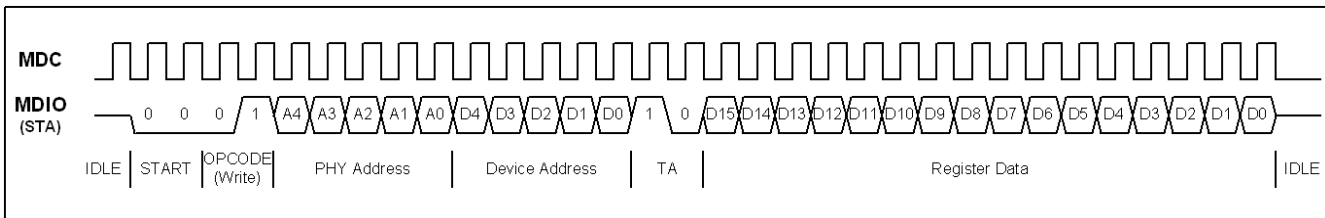



### 3.5.1 Clause 45 MDIO Framing

The extensions for Clause 45 MDIO indirect register accesses are specified in [Table 22](#).

**Table 22: Extensions for Management Frame Format for Indirect Access**

| Frame          | PRE   | ST | OP | PHYAD | DEVADR | TA | ADDRESS/DATA     | Idle |
|----------------|-------|----|----|-------|--------|----|------------------|------|
| Address        | 1...1 | 00 | 00 | PPPPP | DDDDD  | 10 | AAAAAAAAAAAAAAAA | Z    |
| Write          | 1...1 | 00 | 01 | PPPPP | DDDDD  | 10 | DDDDDDDDDDDDDDDD | Z    |
| Read           | 1...1 | 00 | 11 | PPPPP | DDDDD  | Z0 | DDDDDDDDDDDDDDDD | Z    |
| Read Increment | 1...1 | 00 | 10 | PPPPP | DDDDD  | Z0 | DDDDDDDDDDDDDDDD | Z    |

The MDIO implements a 16-bit address register that stores the address of the register to be accessed. For an address cycle, it contains the address of the register to be accessed on the next cycle. For read, write, post-read-increment-address cycles, the field contains the data for the register. At power up and reset, the contents of the register are undefined.

Write, read, and post-read-increment-address frames access the address register, though write and read frames do not modify the contents of the address register.

### 3.5.2 30 MHz High-Speed MDC/MDIO Management Interface Protocol

In addition to supporting the typical MDC/MDIO protocol, the device has the capability to run MDC down to a clock period of 35 ns. The write operation can operate normally at this speed; however, for the read operation, the MDC clock cycle must be slowed down for the TA period as shown in the [Figure 8](#).

During read operations, the MDC clock must slow down so that the PHY has sufficient time to retrieve the data.

See [Section 6.4.4, MDC/MDIO Management Interface Timing, on page 123](#) for timing details.

**Figure 8: 30 MHz MDC/MDIO Read Operation**

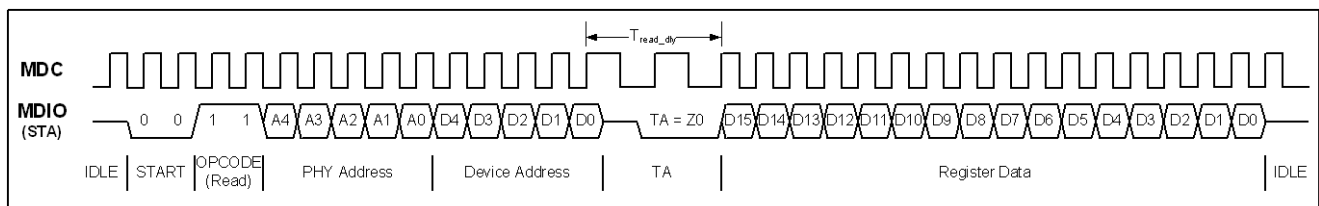

### 3.5.3 Independent MDC/MDIO Support

The 88E2040L device can be configured to operate with 1, 2, or 4 MDC/MDIO interfaces by setting the MDIO[1:0] configuration bits during hardware reset. The behavior is shown in [Table 23](#).

**Table 23: 88E2040L Device MDC/MDIO Interface Mapping**

| MDIO[1:0] Configuration Bit | 00                       | 01                      | 10              |
|-----------------------------|--------------------------|-------------------------|-----------------|
| MDC[0]/MDIO[0]              | Pull-low/Do not connect  | Pull-low/Do not connect | Port 0 MDC/MDIO |
| MDC[1]/MDIO[1]              | Pull-low/Do not connect  | Port 0, 1 MDC/MDIO      | Port 1 MDC/MDIO |
| MDC[2]/MDIO[2]              | Port 0, 1, 2, 3 MDC/MDIO | Port 2, 3 MDC/MDIO      | Port 2 MDC/MDIO |
| MDC[3]/MDIO[3]              | Pull-low/Do not connect  | Pull-low/Do not connect | Port 3 MDC/MDIO |







Setting register 31.F001.11 to 1 powers down the entire port. Care should be used when setting this bit. When this bit is set to 1, there is no way to clear this bit via processor instructions. Clear this bit through a hardware reset or via an MDC/MDIO write.

Setting registers 1.0000.11 or 3.0000.11 to 1 powers down the T Unit only.

Setting registers 4.0000.11, 4.1000.11, or 4.2000.11 to 1 powers down the H Unit only.

### 3.7.2 MAC Interface Power Down

Register 31.F000.3 controls whether the H Unit is powered down while the link is down.

0 = Power down when the link is down.

1 = Always keep the H Unit powered up.

### 3.7.3 Controlling and Sensing

Register 31.F013 controls whether LED[3:0] pins are inputs or outputs. Each pin can be individually controlled.

Register 31.F012 allows the pins to be controlled and sensed. When configured as input, a read to register 31.F012 will return the real-time sampled state of the pin at the time of the read. A write will write the output register, but it have no immediate effect on the pin since the pin is configured to be an input. The input is sampled once every 38.4 ns.

When configured as output, a read to register 31.F012 will return the value in the output register. A write will write the output register which will in turn drive the state of the pin.

## 3.8 LED

The LED[3:0] pins can be used to drive LED pins. Registers 31.F020 through 31.F027 control the operation of the LED pins. LED[3:0] are used to configure the PHY per [Section 3.4.2](#).

[Figure 10](#) shows the general chaining of function for the LEDs. The various functions are described in the following sections.

Figure 10: LED Chain

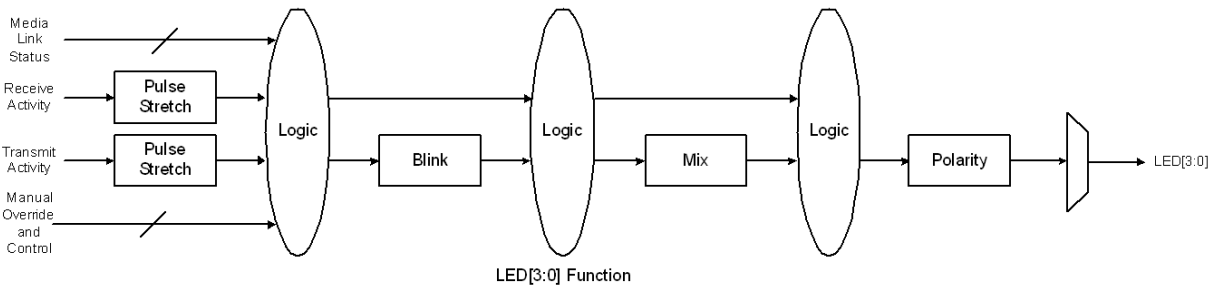

### 3.8.1 LED Polarity

There are a variety of ways to hook up the LEDs. Some examples are shown in [Figure 11](#). Registers 31.F023.1:0, 31.F022.1:0, 31.F021.1:0, and 31.F020.1:0 specify the output polarity for the LED[3:0] function to accommodate a variety of installation options. The lower bit of each pair specifies the on (active) state of the LED, either high or low. The upper bit of each pair specifies whether the off state of the LED should be driven to the opposite level of the on state or Hi-Z. The Hi-Z state is useful in cases such the LOS and INIT function where the inactive state is Hi-Z.

Figure 11: Various LED Hookup Configurations

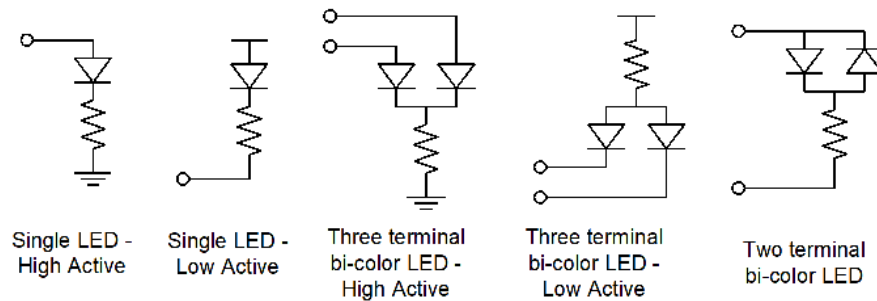

### 3.8.2 Pulse Stretching and Blinking

Register 31.F027.14:12 specifies the pulse stretching duration of a particular activity. Only the transmit activity, receive activity, collision activity, and (transmit or receive) activity are stretched. All other statuses are not stretched since they are static in nature and no stretching is required.

Some status will require blinking state instead of a solid on state. Registers 31.F027.10:8 and 31.F027.6:4 specify the two blink rates. The pulse stretching is applied first and the blinking will reflect the duration of the stretched pulse.

Registers 31.F020.2, 31.F021.2, 31.F022.2, and 31.F023.2 select which of the two blink rates to use for LED[0] to LED[3], respectively.

- 0 = Select Blink Rate 1.
- 1 = Select Blink Rate 2.

The stretched or blinked output will be mixed if needed (see [Section 3.8.3](#)) and then inverted/Hi-Z according to the polarity described in [Section 3.8.1](#).

### 3.8.3 Bi-Color LED Mixing

In the dual LED modes, the mixing function allows the 2 colors of the LED to be mixed to form a third color. This is useful since the PHY supports 10/100 Mbps, 1G, and 5G/2.5G operation speeds. Register 31.F026.7:4 controls the amount to mix in the LED[3], and LED[1] pins. Register 31.F026.3:0 controls the amount to mix in the LED[2] and LED[0] pins. Mixing is determined by the percentage of time the LED is on during the active state. The percentage is selectable in 12.5% increments.

There are two classes of bi-color LEDs: three-terminal type and two-terminal type. For example, the third and fourth LED block from the left in [Figure 11](#) illustrates three-terminal types and the block on the far right is the two-terminal type. In the three-terminal type, both of the LEDs can be turned on at the same time. So the sum of the percentage specified by 31.F026.7:4 and 31.F026.3:0 can exceed 100%. However, in the two-terminal type, the sum should never exceed 100% since only one LED can be turned on at any given time.

Mixing only applies when register 31.F020.12:8 or 31.F022.12:8 are set to 11xxx. There is no mixing in single LED modes.

The behavior for the various dual LED modes are described in [Table 24](#).

**Table 24: Dual LED Mode Behavior**

| Dual Mode Description             | Blink Mix    |              | Solid Mix    |              | Speed Type 1 |              | Speed Type1  |              | Speed Type 2 |              | Speed Type 2 |              |
|-----------------------------------|--------------|--------------|--------------|--------------|--------------|--------------|--------------|--------------|--------------|--------------|--------------|--------------|
| 31.F020,<br>31.F022, bits<br>12:8 | 11010        |              | 11011        |              | 11100        |              | 11101        |              | 11110        |              | 11111        |              |
| Current State                     | LED3<br>LED1 | LED2<br>LED0 | LED3<br>LED1 | LED2<br>LED0 | LED3<br>LED1 | LED2<br>LED0 | LED3<br>LED1 | LED2<br>LED0 | LED3<br>LED1 | LED2<br>LED0 | LED3<br>LED1 | LED2<br>LED0 |
| 5/2.5 Gbps                        | Blink<br>Mix | Blink<br>Mix | Solid<br>Mix | Solid<br>Mix | Solid        | Off          | Solid        | Off          | Solid        | Off          | Solid        | Off          |
| 1 Gbps                            | Blink<br>Mix | Blink<br>Mix | Solid<br>Mix | Solid<br>Mix | Solid<br>Mix | Solid<br>Mix | Solid<br>Mix | Solid<br>Mix | Off          | Solid        | Off          | Solid        |
| 100 Mbps Link                     | Blink<br>Mix | Blink<br>Mix | Solid<br>Mix | Solid<br>Mix | Off          | Solid        | Off          | Solid        | Solid<br>Mix | Solid<br>Mix | Solid<br>Mix | Solid<br>Mix |
| 10 Mbps Link                      | Blink<br>Mix | Blink<br>Mix | Solid<br>Mix | Solid<br>Mix | Off          | Off          | Off          | Off          | Off          | Off          | Off          | Off          |
| Link Down                         | Blink<br>Mix | Blink<br>Mix | Solid<br>Mix | Solid<br>Mix | Off          | Off          | Off          | Off          | Off          | Off          | Off          | Off          |

### 3.8.4 Modes of Operation

The LED pins relay various statuses of the PHY so that they can be displayed by the LEDs.

The basic statuses are shown in [Table 25](#). The compound statuses are formed with the basic status plus the speed information as shown in [Table 26](#). The status information is generated by the copper (T Unit) interfaces.

**Table 25: Basic LED Status**

| Status      | Copper          |
|-------------|-----------------|
| Transmit    | Copper Transmit |
| Receive     | Copper Receive  |
| Link        | Copper Link     |
| Full Duplex | Copper Duplex   |
| Master      | Master/Slave    |

**Table 26: Compound LED Status**

| Compound Status                  | Copper  |
|----------------------------------|---|
| Transmit or Receive              | Copper Transmit or Copper Receive                         |
| Collision (Transmit and Receive) | Copper Transmit and Copper Receive and Copper Half Duplex |
| 10 Mbps Link                     | Copper Speed = 10 Mbps and Copper Link                    |
| 100 Mbps Link                    | Copper Speed = 100 Mbps and Copper Link                   |

**Table 26: Compound LED Status (Continued)**

| Compound Status                              | Copper  |
|--|---|
| 1 Gbps Link                                  | Copper Speed = 1 Gbps and Copper Link                             |
| 5/2.5 Gbps Link                              | Copper Speed = 5/2.5 Gbps and Copper Link                         |
| Link   | Copper Link   |
| Half Duplex                                  | Not Copper Full Duplex  |
| Slave  | Not Master  |
| 10 Mbps Link or 100 Mbps Link                | Copper 10 Mbps Link or Copper 100 Mbps Link                       |
| 10 Mbps Link or 100 Mbps Link or 1 Gbps Link | Copper 10 Mbps Link or Copper 100 Mbps Link or Copper 1 Gbps Link |
| 100 Mbps Link or 5/2.5 Gbps Link             | Copper 100 Mbps or Copper 5/2.5 Gbps Link                         |
| 1 Gbps or 5/2.5 Gbps Link                    | Copper 1 Gbps or Copper 5/2.5 Gbps Link                           |

The status that the LED displays is defined by registers 31.F020 to 31.F023 as shown in [Table 25](#) and [Table 26](#). For each LED if the condition selected by bits 12:8 is true the LED will blink. If the condition selected by bits 7:3 is true, then the LED will be solid on. If both selected conditions are true, then the blink will take precedence.

### 3.8.5 Speed Blink

When 31.F020.7:3 is set to 11111, the LED[0] pin assumes the following behavior:

- LED[0] outputs the sequence shown in [Table 27](#) depending on the status of the link. The sequence consists of 10 segments.
- For a 10 Gbps link, 4 pulses are output.
- For a 1000 Mbps link, 3 pulses are output.
- For a 100 Mbps link, 2 pulses are output.
- For a 10 Mbps link, 1 pulse is output.
- No link outputs 0 pulses.
- The sequence repeats indefinitely.
- The odd-numbered segment pulse duration is specified in 31.F027.1:0. The even-numbered segment pulse duration is specified in 31.F027.3:2.

**Table 27: Speed Blinking Sequence**

| Segment | 10 Mbps | 100 Mbps | 1 Gbps | 10 Gbps | No Link | Duration    |
|---------|---------|----------|--------|---------|---------|-------------|
| 1       | On      | On       | On     | On      | Off     | 31.F027.3:2 |
| 2       | Off     | Off      | Off    | Off     | Off     | 31.F027.1:0 |
| 3       | Off     | On       | On     | On      | Off     | 31.F027.3:2 |
| 4       | Off     | Off      | Off    | Off     | Off     | 31.F027.1:0 |
| 5       | Off     | Off      | On     | On      | Off     | 31.F027.3:2 |
| 6       | Off     | Off      | Off    | Off     | Off     | 31.F027.1:0 |
| 7       | Off     | Off      | Off    | On      | Off     | 31.F027.3:2 |
| 8       | Off     | Off      | Off    | Off     | Off     | 31.F027.1:0 |
| 9       | Off     | Off      | Off    | Off     | Off     | 31.F027.3:2 |



Table 27: Speed Blinking Sequence (Continued)

| Segment | 10 Mbps | 100 Mbps | 1 Gbps | 10 Gbps | No Link | Duration    |
|---------|---------|----------|--------|---------|---------|-------------|
| 10      | Off     | Off      | Off    | Off     | Off     | 31.F027.1:0 |

### 3.8.6 Combo LED Modes

Combo LED mode is activated when register 31.F024.15 is set to 1.

#### 3.8.6.1 Combo LED Mode Select

There are five Combo LED modes which are set by 31.F024.14:12 as described in [Table 28](#).

Table 28: Combo LED Modes

| Combo LED Mode                                  | Function   |                                |   |             |   |  |
|---|--|--------------------------------|---|-------------|---|--|
| <b>Combo LED Mode 1</b><br>(31.F02414:12 = 000) | <b>Link Down</b>   | <b>Link up and no activity</b> | <b>Link up and activity</b>                           |             | <b>Faulty link (including crc error, alignment, runt and jabber errors)</b>                                     |  |
| LED0  | Off  | Solid green                    | Flashing green (rate determined by number of packets) |             | When TIMER_A is high, LED0 is on and green LED1 is off; when TIMER_A is low, LED0 is off, LED1 is on and amber. |  |
| LED1  | Off  | Off                            | Off   |             | Default = TIMER_A on for 0.5s off for 0.5s  |  |
| <b>Combo LED Mode 2</b><br>(31.F02414:12 = 001) | <b>CRC Error</b>   | <b>Alignment</b>               | <b>Runt</b>   |             | <b>Jabber</b>   |  |
| LED0  | LED0 is green when TIMER_B is high, default = LED0 high for 168 ms, LED1 low for 168 ms. |                                |   |             |   |  |
| LED1  | LED1 amber is on when TIMER_B is low.  |                                |   |             |   |  |
| <b>Combo LED Mode 3</b><br>(31.F02414:12 = 010) | <b>STP<sup>a</sup> blocked/disabled</b>  |                                |   |             |   |  |
| LED0  | Off  |                                |   |             |   |  |
| LED1  | On (solid amber)   |                                |   |             |   |  |
| <b>Combo LED Mode 4</b><br>(31.F02414:12 = 011) | STP is blocked, but is it still receiving/sending data.                                  |                                |   |             |   |  |
| LED0  | Off  |                                |   |             |   |  |
| LED1  | On/Off as per TIMER_D (flashing amber), default = 41 ms on and 41 ms off                 |                                |   |             |   |  |
| <b>Combo LED Mode 5</b><br>(31.F02414:12 = 100) | <b>10 Mbps</b>   | <b>100 Mbps</b>                | <b>1000 Mbps</b>                                      | <b>2.5G</b> | <b>5G</b>   |  |

**Table 28: Combo LED Modes (Continued)**

| Combo LED Mode | Function |     |   |   |  |  |
|----------------|----------|-----|---|---|--|--|
| LED0           | Off      | On  | On 5%<br>(105 ms)<br>Off 95%<br>(1895 ms)<br>Rate =<br>TIMER_1G | On 10% (210 ms)<br>Off 90% (1790 ms)<br>Rate = TIMER_<br>2.5G | On 20%<br>(420 ms)<br>Off 80%<br>(1580 ms)<br>Rate =<br>TIMER_5G |  |
| LED1           | Off      | Off | Off   | Off   | Off  |  |

a. Spanning Tree Protocol

**Table 29: Combo Mode Timer Control**

| Mode | Rate  | Setting  |
|------|---|--|
| 1    | When the link is up, the flashing rate is based on the number of frames received within 2 ms. | Refer to <a href="#">Table 30</a> for flashing rate setup. |
| 1    | Faulty Link   | TIMER_A = 31.F024.7:0                                      |
| 2    | CRC, alignment, Runt, and Jabber Errors   | TIMER_B = 31.F029.15:8                                     |
| 4    | STP is blocked, but it still receiving/sending data.  | TIMER_D = 31.F039.7:0                                      |
| 5    | 1G  | TIMER_1G = 31.F028.7:0                                     |
|      | 2.5G  | TIMER_2.5G = 31.F028.15:8                                  |
|      | 5G  | TIMER_5G = 31.F029.7:0                                     |



### 3.8.6.2 LED Activity Control

When the Combo LED Mode Selection bits (31.F024.14:12) are set to 000 and the link is up, the flash/blink activity of LED0 indicates the number of frames received within the last 2.1 seconds. Activity flashing of the LED is based on the transmitted and received frames on a link. Register 31.F026.11:10 is used to monitor transmit (31.F026.11:10 = 00) or receive (31.F026.11:10 = 01) or both (31.F026.11:10 = 11) at the same time.

LED0 can flash in two different ways:

- When Combo LED flash bit is set to 0, the more packets received within the previous 2100 ms, the longer LED0 stays on.
- When Combo LED flash bit is set to 1, the more packets received within the previous 2100 ms, the faster LED0 blinks.

The Combo LED flash rate details are listed in [Table 30](#).

**Table 30: Combo LED Flash Mode**

| Combo LED Flash (31.F024.11) | Flash Rate  |
|------------------------------|---|
| 0                            | <p>&lt;10: on for 31.F030[7:0], the remaining of 2.1s off;<br/>           &lt;10<sup>2</sup>: on for 31.F030[15:8], the remaining of 2.1s off;<br/>           &lt;5*10<sup>2</sup>: on for 31.F031[7:0], the remaining of 2.1s off;<br/>           &lt;10<sup>3</sup>: on for 31.F031[15:8], the remaining of 2.1s off;<br/>           &lt;5*10<sup>3</sup>: on for 31.F032[7:0], the remaining of 2.1s off;<br/>           &lt;10<sup>4</sup>: on for 31.F032[15:8], the remaining of 2.1s off;<br/>           &lt;5*10<sup>4</sup>: on for 31.F033[7:0], the remaining of 2.1s off;<br/>           &lt;10<sup>5</sup>: on for 31.F033[15:8], the remaining of 2.1s off;<br/>           &lt;5*10<sup>5</sup>: on for 31.F034[7:0], the remaining of 2.1s off;<br/>           &lt;10<sup>6</sup>: on for 31.F034[15:8], the remaining of 2.1s off;<br/>           &lt;5*10<sup>6</sup>: on for 31.F035[7:0], the remaining of 2.1s off;<br/>           &lt;10<sup>7</sup>: on for 31.F035[15:8], the remaining of 2.1s off</p> <p><b>NOTE:</b> For registers 31.F030, 31.F031, 31.F032, 31.F033, 31.F034, and 31.F035, the unit of bit[7:0] and [15:8] is 21 ms. Any value greater than 8'd100 will be ignored.</p> |
| 1                            | <p>&lt;10: LED on/off every 1/2 of 2.1s;<br/>           &lt;10<sup>2</sup>: LED on/off every 1/4 of 2.1s;<br/>           &lt;5*10<sup>2</sup>: LED on/off every 1/8 of 2.1s;<br/>           &lt;10<sup>3</sup>: LED on/off every 1/16 of 2.1s;<br/>           &lt;5*10<sup>3</sup>: LED on/off 1/32 of 2.1s;<br/>           &lt;10<sup>4</sup>: LED on/off 1/64 of 2.1s;<br/>           &lt;5*10<sup>4</sup>: LED on/off 1/128 of 2.1s;<br/>           &lt;10<sup>5</sup>: LED on/off 1/256 of 2.1s;<br/>           &lt;5*10<sup>5</sup>: LED on/off 1/512 of 2.1s;<br/>           &lt;10<sup>6</sup>: LED on/off 1/1024 of 2.1s;<br/>           &lt;5*10<sup>6</sup>: LED on/off 1/2048 of 2.1s;<br/>           &lt;10<sup>7</sup>: LED on/off 1/4096 of 2.1s</p>  |

For example:

When the number of frames received within 2.1 seconds is 4000, in the following 2.1 seconds, the LED will behave as follows:

- If 31.F024.11 = 0, then LED0 will be on for 31.F031[7:0] \* 21 ms, and off for (100 - 31.F031[7:0]) \* 21 ms.
- If 31.F024.11 = 1, then LED0 will on for 1/32 \* 2100 ms and off for 1/32 \* 2100 ms repeatedly for 2.1 seconds.



## 3.9 Interrupt

The T, H, and P Units and the GPIO function can generate interrupts.

The Unit Interrupt Status Register (see 31.F040) shows a summary of which unit is requesting the interrupt.

Each bit of the Unit Interrupt Status Register will be masked with the Unit Interrupt Mask Register (see 31.F043) respectively, and each masked output is ORed to form the aggregated unit interrupt.

The Port Interrupt Status (see 31.F042.0) is the result of logical OR of the aggregated unit interrupt request along with register 31.F041.0 (see Force Interrupt bit) to form the port interrupt. When the bit is 1, the INTn will be driven as an active interrupt exists. The INTn's polarity is controlled by 31.F041.2:0.

In case of multiple port devices such as 88E2040L, INTn is active when one or more ports have the active Port Interrupt. There is no aggregated interrupt register for all ports. So, the Port Interrupt bit (see 31.F042.0) for all ports should be examined to determine which port or how many ports have pending interrupt requests.

The Interrupt Polarity bits (see 31.F041.2:1) for the INTn pin are valid only from Port 0. Other port's Polarity control bit are not valid; however, setting register 31.F041.0 in any port will force the INTn pin as active.



## 3.10 IEEE 1149.1 and 1149.6 Controller

The IEEE 1149.1 standard defines a test access port and boundary-scan architecture for digital integrated circuits and for the digital portions of mixed analog/digital integrated circuits. The IEEE 1149.6 standard defines a test access port and boundary-scan architecture for AC-coupled signals.

This standard provides a solution for testing assembled printed circuit boards and other products based on highly complex digital integrated circuits and high-density surface-mounting assembly techniques.

The device implements the instructions shown in [Table 31](#). Upon reset, ID\_CODE instruction is selected. The PROG\_HYST is a proprietary command used to adjust the test receiver hysteresis threshold. The instruction opcodes are shown in [Table 31](#).

[Table 32](#) and [Table 34](#) list the 88E2010 and 88E2040L device boundary scan orders, respectively, where:

TDI → P0\_SON/P[0] (AC/DC) → ... → SPI\_SS<sub>n</sub>(Output) → TDO

**Table 31: TAP Controller Opcodes**

| Instruction    | OpCode   |
|----------------|----------|
| EXTEST         | 00000000 |
| SAMPLE/PRELOAD | 00000001 |
| CLAMP          | 00000010 |
| HIGH-Z         | 00000011 |
| ID_CODE        | 00000100 |
| EXTEST_PULSE   | 00000101 |
| EXTEST_TRAIN   | 00000110 |
| PROG_HYST      | 00001000 |
| BYPASS         | 11111111 |

The device reserves five pins called the Test Access Port (TAP) to provide test access:

- Test Mode Select Input (TMS)
- Test Clock Input (TCK)
- Test Data Input (TDI)
- Test Data Output (TDO)
- Test Reset Input (TRST<sub>n</sub>)

To ensure race-free operation, all input and output data is synchronous with the test clock (TCK). TAP input signals (TMS and TDI) are clocked into the test logic on the rising edge of TCK, while output signal (TDO) is clocked on the falling edge. For additional details, refer to the IEEE 1149.1 Boundary Scan Architecture document.

### 3.10.1 BYPASS Instruction

The BYPASS instruction uses the bypass register. This register contains a single shift-register stage and is used to provide a minimum length serial path between the TDI and TDO pins of the device when test operation is not required. This arrangement allows rapid movement of test data to and from other testable devices in the system.

### 3.10.2 SAMPLE/PRELOAD Instruction

The SAMPLE/PRELOAD instruction enables scanning of the boundary-scan register without causing interference to the normal operation of the device. Two functions are performed when this instruction is selected: SAMPLE and PRELOAD.

SAMPLE allows a snapshot to be taken of the data flowing from the system pins to the on-chip test logic or vice versa, without interfering with normal operation. The snapshot is taken on the rising edge of TCK in the Capture-DR controller state, and the data can be viewed by shifting through the component's TDO output.

While sampling and shifting data out through TDO for observation, PRELOAD enables an initial data pattern to be shifted in through TDI and to be placed at the latched parallel output of the boundary-scan register cells that are connected to system output pins. This step ensures that known data is driven through the system output pins upon entering the extest instruction. Without PRELOAD, indeterminate data would be driven until the first scan sequence is complete. The shifting of data for the sample and preload phases can occur simultaneously. While data capture is being shifted out, the preload data can be shifted in.



Table 32: 88E2010 Boundary Scan Chain Order

| Order | Pin                 | I/O           |
|-------|---------------------|---------------|
| 1     | SPI_SS <sub>n</sub> | Output        |
| 2     | SPI_SS <sub>n</sub> | Output Enable |
| 3     | SPI_CLK             | Output        |
| 4     | SPI_CLK             | Output Enable |
| 5     | SPI_MOSI            | Output        |
| 6     | SPI_MOSI            | Output Enable |
| 7     | SPI_MISO            | Input         |
| 8     | RESET <sub>n</sub>  | Input         |
| 9     | RCLK1               | Output        |
| 10    | RCLK1               | Output Enable |
| 11    | RCLK0               | Output        |
| 12    | RCLK0               | Output Enable |
| 13    | CONFIG[7]           | Input         |
| 14    | CONFIG[6]           | Input         |
| 15    | CONFIG[5]           | Input         |
| 16    | CONFIG[4]           | Input         |
| 17    | CONFIG[3]           | Input         |
| 18    | CONFIG[2]           | Input         |
| 19    | CONFIG[1]           | Input         |
| 20    | CONFIG[0]           | Input         |
| 21    | MDIO[0]             | Input         |
| 22    | MDIO[0]             | Output        |
| 23    | MDIO[0]             | Output Enable |
| 24    | MDC[0]              | Input         |
| 25    | P0_LED[3]           | Input         |
| 26    | P0_LED[3]           | Output        |
| 27    | P0_LED[3]           | Output Enable |
| 28    | P0_LED[2]           | Input         |
| 29    | P0_LED[2]           | Output        |

Table 32: 88E2010 Boundary Scan Chain Order (Continued)

| Order | Pin              | I/O           |
|-------|------------------|---------------|
| 30    | P0_LED[2]        | Output Enable |
| 31    | P0_LED[1]        | Input         |
| 32    | P0_LED[1]        | Output        |
| 33    | P0_LED[1]        | Output Enable |
| 34    | P0_LED[0]        | Input         |
| 35    | P0_LED[0]        | Output        |
| 36    | P0_LED[0]        | Output Enable |
| 37    | Reserved         | Input         |
| 38    | Reserved         | Output        |
| 39    | Reserved         | Output Enable |
| 40    | Reserved         | Input         |
| 41    | Reserved         | Output        |
| 42    | Reserved         | Output Enable |
| 43    | Reserved         | Input         |
| 44    | Reserved         | Output        |
| 45    | Reserved         | Output Enable |
| 46    | Reserved         | Input         |
| 47    | Reserved         | Output        |
| 48    | Reserved         | Output Enable |
| 49    | Reserved         | Input         |
| 50    | Reserved         | Output        |
| 51    | Reserved         | Output Enable |
| 52    | Reserved         | Input         |
| 53    | Reserved         | Output        |
| 54    | Reserved         | Output Enable |
| 55    | INT <sub>n</sub> | Output        |
| 56    | INT <sub>n</sub> | Output Enable |
| 57    | CLK_SEL[1]       | Input         |

**Table 32: 88E2010 Boundary Scan Chain Order (Continued)**

| Order | Pin                     | I/O          |
|-------|-------------------------|--------------|
| 58    | CLK_SEL[0]              | Input        |
| 59    | P0_SIN[3]               | Input        |
| 60    | P0_SIP[3]               | Input        |
| 61    | P0_SON[3]/<br>P0_SOP[3] | Output       |
| 62    | P0_SON[3]/<br>P0_SOP[3] | AC/DC Select |
| 63    | P0_SIN[2]               | Input        |
| 64    | P0_SIP[2]               | Input        |
| 65    | P0_SON[2]/<br>P0_SOP[2] | Output       |
| 66    | P0_SON[2]/<br>P0_SOP[2] | AC/DC Select |
| 67    | P0_SIN[1]               | Input        |
| 68    | P0_SIP[1]               | Input        |
| 69    | P0_SON[1]/<br>P0_SOP[1] | Output       |
| 70    | P0_SON[1]/<br>P0_SOP[1] | AC/DC Select |
| 71    | P0_SIN[0]               | Input        |
| 72    | P0_SIP[0]               | Input        |
| 73    | P0_SON[0]/<br>P0_SOP[0] | Output       |
| 74    | P0_SON[0]/<br>P0_SOP[0] | AC/DC Select |



**Table 33: 88E2010 Boundary Scan Exclusion List**

| Pin       | I/O    |
|-----------|--------|
| MDIN[0]   | Analog |
| MDIN[1]   | Analog |
| MDIN[2]   | Analog |
| MDIN[3]   | Analog |
| MDIP[0]   | Analog |
| MDIP[1]   | Analog |
| MDIP[2]   | Analog |
| MDIP[3]   | Analog |
| TSTCP     | Analog |
| TSTCN     | Analog |
| TEST_CLKP | Analog |
| TEST_CLKN | Analog |
| CMN       | Analog |
| CMP       | Analog |
| ATN       | Analog |
| ATP       | Analog |
| CIREF     | Analog |
| SIREF     | Analog |
| CLKP      | Analog |
| CLKN      | Analog |
| XTAL1     | Analog |
| XTAL2     | Analog |
| CHSDACP   | Analog |
| CHSDACN   | Analog |
| SHSDACP   | Analog |
| SHSDACN   | Analog |
| CTSTPT    | Analog |
| STSTPT    | Analog |
| TEST      | Analog |

**Table 33: 88E2010 Boundary Scan Exclusion List (Continued)**

| Pin     | I/O    |
|---------|--------|
| VDDCTRL | Analog |
| TDI     | JTAG   |
| TDO     | JTAG   |
| TMS     | JTAG   |
| TCK     | JTAG   |
| TRSTn   | JTAG   |
| VSEL_L  | Power  |
| VSEL_M  | Power  |
| VSEL_R  | Power  |
| VSEL_T  | Power  |
| VHV     | Power  |
| AVDDL   | Power  |
| AVDDH   | Power  |
| AVDDT   | Power  |
| AVSSC   | Power  |
| AVSS    | Power  |
| VDDR09  | Power  |
| AVDDS   | Power  |
| AVDDR   | Power  |
| AVDDC   | Power  |
| DVDD    | Power  |
| VDDOL   | Power  |
| VDDOM   | Power  |
| VDDOR   | Power  |
| VDDOT   | Power  |
| VSS     | Power  |

**Table 34: 88E2040L Boundary Scan Chain Order**

| Order | Pin                 | I/O           |
|-------|---------------------|---------------|
| 1     | SPI_SS <sub>n</sub> | Output        |
| 2     | SPI_SS <sub>n</sub> | Output Enable |
| 3     | SPI_CLK             | Output        |
| 4     | SPI_CLK             | Output Enable |
| 5     | SPI_MOSI            | Output        |
| 6     | SPI_MOSI            | Output Enable |
| 7     | SPI_MISO            | Input         |
| 8     | RESET <sub>n</sub>  | Input         |
| 9     | RCLK1               | Output        |
| 10    | RCLK1               | Output Enable |
| 11    | RCLK0               | Output        |
| 12    | RCLK0               | Output Enable |
| 13    | CONFIG[7]           | Input         |
| 14    | CONFIG[6]           | Input         |
| 15    | CONFIG[5]           | Input         |
| 16    | CONFIG[4]           | Input         |
| 17    | CONFIG[3]           | Input         |
| 18    | CONFIG[2]           | Input         |
| 19    | CONFIG[1]           | Input         |
| 20    | CONFIG[0]           | Input         |
| 21    | MDIO[3]             | Input         |
| 22    | MDIO[3]             | Output        |
| 23    | MDIO[3]             | Output Enable |
| 24    | MDC[3]              | Input         |
| 25    | P3_LED[3]           | Input         |
| 26    | P3_LED[3]           | Output        |
| 27    | P3_LED[3]           | Output Enable |
| 28    | P3_LED[2]           | Input         |
| 29    | P3_LED[2]           | Output        |

**Table 34: 88E2040L Boundary Scan Chain Order (Continued)**

| Order | Pin                  | I/O           |
|-------|----------------------|---------------|
| 30    | P3_LED[2]            | Output Enable |
| 31    | P3_LED[1]            | Input         |
| 32    | P3_LED[1]            | Output        |
| 33    | P3_LED[1]            | Output Enable |
| 34    | P3_LED[0]            | Input         |
| 35    | P3_LED[0]            | Output        |
| 36    | P3_LED[0]            | Output Enable |
| 37    | Reserved             | Input         |
| 38    | Reserved             | Output        |
| 39    | Reserved             | Output Enable |
| 40    | Reserved             | Input         |
| 41    | Reserved             | Output        |
| 42    | Reserved             | Output Enable |
| 43    | Reserved             | Input         |
| 44    | Reserved             | Output        |
| 45    | Reserved             | Output Enable |
| 46    | P3_SIN[1]            | Input         |
| 47    | P3_SIP[1]            | Input         |
| 48    | P3_SON[1]/ P3_SOP[1] | Output        |
| 49    | P3_SON[1]/ P3_SOP[1] | AC/DC Select  |
| 50    | P3_SIN[0]            | Input         |
| 51    | P3_SIP[0]            | Input         |
| 52    | P3_SON[0]/ P3_SOP[0] | Output        |
| 53    | P3_SON[0]/ P3_SOP[0] | AC/DC Select  |
| 54    | MDIO[2]              | Input         |
| 55    | MDIO[2]              | Output        |
| 56    | MDIO[2]              | Output Enable |



Table 34: 88E2040L Boundary Scan Chain Order (Continued)

| Order | Pin                  | I/O           |
|-------|----------------------|---------------|
| 57    | MDC[2]               | Input         |
| 58    | P2_LED[3]            | Input         |
| 59    | P2_LED[3]            | Output        |
| 60    | P2_LED[3]            | Output Enable |
| 61    | P2_LED[2]            | Input         |
| 62    | P2_LED[2]            | Output        |
| 63    | P2_LED[2]            | Output Enable |
| 64    | P2_LED[1]            | Input         |
| 65    | P2_LED[1]            | Output        |
| 66    | P2_LED[1]            | Output Enable |
| 67    | P2_LED[0]            | Input         |
| 68    | P2_LED[0]            | Output        |
| 69    | P2_LED[0]            | Output Enable |
| 70    | Reserved             | Input         |
| 71    | Reserved             | Output        |
| 72    | Reserved             | Output Enable |
| 73    | Reserved             | Input         |
| 74    | Reserved             | Output        |
| 75    | Reserved             | Output Enable |
| 76    | Reserved             | Input         |
| 77    | Reserved             | Output        |
| 78    | Reserved             | Output Enable |
| 79    | P2_SIN[1]            | Input         |
| 80    | P2_SIP[1]            | Input         |
| 81    | P2_SON[1]/ P2_SOP[1] | Output        |
| 82    | P2_SON[1]/ P2_SOP[1] | AC/DC Select  |

Table 34: 88E2040L Boundary Scan Chain Order (Continued)

| Order | Pin                  | I/O           |
|-------|----------------------|---------------|
| 83    | P2_SIN[0]            | Input         |
| 84    | P2_SIP[0]            | Input         |
| 85    | P2_SON[0]/ P2_SOP[0] | Output        |
| 86    | P2_SON[0]/ P2_SOP[0] | AC/DC Select  |
| 87    | MDIO[1]              | Input         |
| 88    | MDIO[1]              | Output        |
| 89    | MDIO[1]              | Output Enable |
| 90    | MDC[1]               | Input         |
| 91    | P1_LED[3]            | Input         |
| 92    | P1_LED[3]            | Output        |
| 93    | P1_LED[3]            | Output Enable |
| 94    | P1_LED[2]            | Input         |
| 95    | P1_LED[2]            | Output        |
| 96    | P1_LED[2]            | Output Enable |
| 97    | P1_LED[1]            | Input         |
| 98    | P1_LED[1]            | Output        |
| 99    | P1_LED[1]            | Output Enable |
| 100   | P1_LED[0]            | Input         |
| 101   | P1_LED[0]            | Output        |
| 102   | P1_LED[0]            | Output Enable |
| 103   | Reserved             | Input         |
| 104   | Reserved             | Output        |
| 105   | Reserved             | Output Enable |
| 106   | Reserved             | Input         |
| 107   | Reserved             | Output        |
| 108   | Reserved             | Output Enable |
| 109   | Reserved             | Input         |



**Table 34: 88E2040L Boundary Scan Chain Order (Continued)**

| Order | Pin                  | I/O           |
|-------|----------------------|---------------|
| 110   | Reserved             | Output        |
| 111   | Reserved             | Output Enable |
| 112   | P1_SIN[1]            | Input         |
| 113   | P1_SIP[1]            | Input         |
| 114   | P1_SON[1]/ P1_SOP[1] | Output        |
| 115   | P1_SON[1]/ P1_SOP[1] | AC/DC Select  |
| 116   | P1_SIN[0]            | Input         |
| 117   | P1_SIP[0]            | Input         |
| 118   | P1_SON[0]/ P1_SOP[0] | Output        |
| 119   | P1_SON[0]/ P1_SOP[0] | AC/DC Select  |
| 120   | MDIO[0]              | Input         |
| 121   | MDIO[0]              | Output        |
| 122   | MDIO[0]              | Output Enable |
| 123   | MDC[0]               | Input         |
| 124   | P0_LED[3]            | Input         |
| 125   | P0_LED[3]            | Output        |
| 126   | P0_LED[3]            | Output Enable |
| 127   | P0_LED[2]            | Input         |
| 128   | P0_LED[2]            | Output        |
| 129   | P0_LED[2]            | Output Enable |
| 130   | P0_LED[1]            | Input         |
| 131   | P0_LED[1]            | Output        |
| 132   | P0_LED[1]            | Output Enable |
| 133   | P0_LED[0]            | Input         |
| 134   | P0_LED[0]            | Output        |
| 135   | P0_LED[0]            | Output Enable |
| 136   | Reserved             | Input         |

**Table 34: 88E2040L Boundary Scan Chain Order (Continued)**

| Order | Pin                  | I/O           |
|-------|----------------------|---------------|
| 137   | Reserved             | Output        |
| 138   | Reserved             | Output Enable |
| 139   | Reserved             | Input         |
| 140   | Reserved             | Output        |
| 141   | Reserved             | Output Enable |
| 142   | Reserved             | Input         |
| 143   | Reserved             | Output        |
| 144   | Reserved             | Output Enable |
| 145   | INTn                 | Output        |
| 146   | INTn                 | Output Enable |
| 147   | CLK_SEL[1]           | Input         |
| 148   | CLK_SEL[0]           | Input         |
| 149   | P0_SIN[1]            | Input         |
| 150   | P0_SIP[1]            | Input         |
| 151   | P0_SON[1]/ P0_SOP[1] | Output        |
| 152   | P0_SON[1]/ P0_SOP[1] | AC/DC Select  |
| 153   | P0_SIN[0]            | Input         |
| 154   | P0_SIP[0]            | Input         |
| 155   | P0_SON[0]/ P0_SOP[0] | Output        |
| 156   | P0_SON[0]/ P0_SOP[0] | AC/DC Select  |



**Table 35: 88E2040L Boundary Scan Exclusion List**

| Pin        | I/O    |
|------------|--------|
| P0_MDIN[0] | Analog |
| P0_MDIN[1] | Analog |
| P0_MDIN[2] | Analog |
| P0_MDIN[3] | Analog |
| P0_MDIP[0] | Analog |
| P0_MDIP[1] | Analog |
| P0_MDIP[2] | Analog |
| P0_MDIP[3] | Analog |
| P1_MDIN[0] | Analog |
| P1_MDIN[1] | Analog |
| P1_MDIN[2] | Analog |
| P1_MDIN[3] | Analog |
| P1_MDIP[0] | Analog |
| P1_MDIP[1] | Analog |
| P1_MDIP[2] | Analog |
| P1_MDIP[3] | Analog |
| P2_MDIN[0] | Analog |
| P2_MDIN[1] | Analog |
| P2_MDIN[2] | Analog |
| P2_MDIN[3] | Analog |
| P2_MDIP[0] | Analog |
| P2_MDIP[1] | Analog |
| P2_MDIP[2] | Analog |
| P2_MDIP[3] | Analog |
| P3_MDIN[0] | Analog |
| P3_MDIN[1] | Analog |
| P3_MDIN[2] | Analog |
| P3_MDIN[3] | Analog |
| P3_MDIP[0] | Analog |

**Table 35: 88E2040L Boundary Scan Exclusion List (Continued)**

| Pin        | I/O    |
|------------|--------|
| P3_MDIP[1] | Analog |
| P3_MDIP[2] | Analog |
| P3_MDIP[3] | Analog |
| TSTCP      | Analog |
| TSTCN      | Analog |
| TEST_CLKN  | Analog |
| TEST_CLKP  | Analog |
| P0_CMN     | Analog |
| P0_CMP     | Analog |
| P1_CMN     | Analog |
| P1_CMP     | Analog |
| P2_CMN     | Analog |
| P2_CMP     | Analog |
| P3_CMN     | Analog |
| P3_CMP     | Analog |
| P0_ATN[1]  | Analog |
| P0_ATN[1]  | Analog |
| P0_ATN[2]  | Analog |
| P0_ATN[3]  | Analog |
| P0_ATP[0]  | Analog |
| P0_ATP[1]  | Analog |
| P0_ATP[2]  | Analog |
| P0_ATP[3]  | Analog |
| P1_ATN[0]  | Analog |
| P1_ATN[1]  | Analog |
| P1_ATN[2]  | Analog |

**Table 35: 88E2040L Boundary Scan Exclusion List (Continued)**

| Pin       | I/O    |
|-----------|--------|
| P1_ATN[3] | Analog |
| P1_ATP[0] | Analog |
| P1_ATP[1] | Analog |
| P1_ATP[2] | Analog |
| P1_ATP[3] | Analog |
| P2_ATN[0] | Analog |
| P2_ATN[1] | Analog |
| P2_ATN[2] | Analog |
| P2_ATN[3] | Analog |
| P2_ATP[0] | Analog |
| P2_ATP[1] | Analog |
| P2_ATP[2] | Analog |
| P2_ATP[3] | Analog |
| P3_ATN[0] | Analog |
| P3_ATN[1] | Analog |
| P3_ATN[2] | Analog |
| P3_ATN[3] | Analog |
| P3_ATP[0] | Analog |
| P3_ATP[1] | Analog |
| P3_ATP[2] | Analog |
| P3_ATP[3] | Analog |
| CIREF     | Analog |
| SIREF     | Analog |
| CLKP      | Analog |
| CLKN      | Analog |
| XTAL1     | Analog |
| XTAL2     | Analog |

**Table 35: 88E2040L Boundary Scan Exclusion List (Continued)**

| Pin      | I/O    |
|----------|--------|
| CHSDACP  | Analog |
| CHSDACN  | Analog |
| SHSDACP  | Analog |
| SHSDACN  | Analog |
| CTSTPT   | Analog |
| STSTPT   | Analog |
| TEST     | Analog |
| TDI      | JTAG   |
| TDO      | JTAG   |
| TMS      | JTAG   |
| TCK      | JTAG   |
| TRSTn    | JTAG   |
| VSEL_L   | Power  |
| VSEL_M   | Power  |
| VSEL_R   | Power  |
| VSEL_T   | Power  |
| P0_VHV   | Power  |
| P1_VHV   | Power  |
| P2_VHV   | Power  |
| P3_VHV   | Power  |
| P0_AVDDL | Power  |
| P1_AVDDL | Power  |
| P2_AVDDL | Power  |
| P3_AVDDL | Power  |
| P0_AVDDH | Power  |
| P1_AVDDH | Power  |
| P2_AVDDH | Power  |
| P3_AVDDH | Power  |



**Table 35: 88E2040L Boundary Scan  
Exclusion List (Continued)**

| Pin       | I/O   |
|-----------|-------|
| P0_AVDDT  | Power |
| P1_AVDDT  | Power |
| P2_AVDDT  | Power |
| P3_AVDDT  | Power |
| AVSSC     | Power |
| AVSS      | Power |
| P0_VDDR09 | Power |
| P1_VDDR09 | Power |
| P2_VDDR09 | Power |
| P3_VDDR09 | Power |
| P0_AVDDS  | Power |
| P1_AVDDS  | Power |
| P2_AVDDS  | Power |
| P3_AVDDS  | Power |
| P0_AVDDR  | Power |
| P1_AVDDR  | Power |
| P2_AVDDR  | Power |
| P3_AVDDR  | Power |
| AVDDC     | Power |
| DVDD      | Power |
| VDDOL     | Power |
| VDDOM     | Power |
| VDDOR     | Power |
| VDDOT     | Power |
| VSS       | Power |

### 3.10.3 EXTEST Instruction

The EXTEST instruction enables circuitry external to the device (typically the board interconnections) to be tested. Prior to executing the EXTEST instruction, the first test stimulus to be applied is shifted into the boundary-scan registers using the SAMPLE/PRELOAD instruction. So, when the change to the extest instruction occurs, known data is driven immediately from the device to its external connections. The SOP/N[1:0] pins will be driven to static levels. The positive and negative legs of the SOP/N[1:0] pins are controlled via a single boundary scan cell. The positive leg outputs the level specified by the boundary scan cell while the negative leg outputs the opposite level.

### 3.10.4 CLAMP Instruction

The CLAMP instruction enables the state of the signals driven from component pins to be determined from the boundary-scan register while the bypass register is selected as the serial path between TDI and TDO. The signals driven from the component pins do not change while the clamp instruction is selected.

### 3.10.5 HIGH-Z Instruction

The HIGH-Z instruction places all of the digital component system logic outputs in an inactive high-impedance drive state. In this state, an in-circuit test system may drive signals onto the connections normally driven by a component output without incurring the risk of damage to the component.

### 3.10.6 ID CODE Instruction

The ID CODE instruction contains the manufacturer identity, part and version.

Table 36: ID CODE Instruction

| Device   | Version      | Part Number      | Manufacturer Identity |       |
|----------|--------------|------------------|-----------------------|-------|
|          | Bit 31 to 28 | Bit 27 to 12     | Bit 11 to 1           | Bit 0 |
| 88E2010  | 0000         | 0000000000011001 | 00111101110           | 1     |
| 88E2040L | 0000         | 0000000000011011 | 00111101110           | 1     |

### 3.10.7 EXTEST\_PULSE Instruction

The AC- or DC-JTAG test modes can be selected for each port individually by scanning in the desired bit value into AC/DC select scan registers shown in the scan chain (Table 32, 88E2010 Boundary Scan Chain Order, on page 84 or Table 34, 88E2040L Boundary Scan Chain Order, on page 87). When the AC/DC select is set to DC the EXTEST\_PULSE instruction has the same behavior as the EXTEST instruction.

When the AC/DC select is set to AC, the EXTEST\_PULSE instruction has the same behavior as the EXTEST instruction except for the behavior of the SOP/N[1:0] pins.

As in the EXTEST instruction, the test stimulus must first be shifted into the boundary-scan registers. Upon the execution of the EXTEST\_PULSE instruction the SOP[1:0] pins output the level specified by the test stimulus and SON[1:0] pins output the opposite level.

However, if the TAP controller enters into the Run-Test/Idle state, then the SON[1:0] pins output the level specified by the test stimulus and SOP[1:0] pins output the opposite level.

When the TAP controller exits the Run-Test/Idle state, the SOP[1:0] pins again output the level specified by the test stimulus and SON[1:0] pins output the opposite level.

#### 3.10.7.1 EXTEST\_TRAIN Instruction

When the AC/DC select is set to DC, the EXTEST\_TRAIN instruction has the same behavior as the EXTEST instruction.

When the AC/DC select is set to AC, the EXTEST\_TRAIN instruction has the same behavior as the EXTEST instruction except for the behavior of the SOP/N[1:0] pins.



As in the EXTEST instruction, the test stimulus must first be shifted into the boundary-scan registers. Upon the execution of the EXTEST\_PULSE instruction the SOP[1:0] pins output the level specified by the test stimulus and SON[1:0] pins output the opposite level.

However, if the TAP controller enters into the Run-Test/Idle state the SOP/N[1:0] will toggle between inverted and non-inverted levels on the falling edge of TCK. This toggling will continue for as long as the TAP controller remains in the Run-Test/Idle state.

When the TAP controller exits the Run-Test/Idle state, the SOP[1:0] pins again output the level specified by the test stimulus and SON[1:0] pins output the opposite level.

### 3.10.8 PROG\_HYST Instruction

The test receivers connected to the XIP/N[3:0] and MIP/N[3:0] pins require the hysteresis level to be set according to the application that the SERDES is used in. The amount of hysteresis required is a function of the expected voltage swing on the input. The proprietary command PROG\_HYST will program three registers in the TAP controller which will set the value of the hysteresis.

When the PROG\_HYST opcode is in the instruction register, the following actions occur in the TAP controller states:

- Capture-DR state: Load the value in HYST[2:0] into SR\_HYST[2:0].
- Shift-DR state: Shift TDI into SR\_HYST[0], SR\_HYST[1:0] into SR\_HYST[2:1], and SR\_HYST[2] to TDO. Three bits should be loaded to set the new test receiver hysteresis value.
- Update-DR state: Load the value in SR\_HYST[2:0] into HYST[2:0].
- HYST[2:0] is the register that sets the hysteresis in the test receiver.
- SR\_HYST[2:0] is the 3-bit shift register used to shift the values in and out.

The hysteresis mapping is shown in [Table 37](#). 70 mV is the default setting. When the TAP controller is in the Test-Logic-Reset state or when TRSTn is forced low, the HYST[2:0] is reset to the default state

**Table 37: Test Receiver Hysteresis Setting**

| HYST[2:0] | Hysteresis |
|-----------|------------|
| 000       | 12 mV      |
| 001       | 25 mV      |
| 010       | 50 mV      |
| 011       | 70 mV      |
| 100       | 90 mV      |
| 101       | 105 mV     |
| 110       | 135 mV     |
| 111       | 150 mV     |

### 3.10.9 AC-JTAG Fault Detection

The fault detection across AC-coupled connections can be detected with a combination of (DC) EXTEST and any one of the AC-JTAG commands. The AC-coupled connection is shown in [Figure 12](#). The fault signature is shown in [Table 38](#). Column 1 lists the fault type.

Columns 2 to 5 lists the behavior when both the transmitter and receiver are running the EXTEST\_TRAIN and EXTEST\_PULSE commands. Column 2 shows the expected value captured by the boundary scan cell that is connected to the test receiver, which is connected to the positive input when a negative differential pulse is transmitted. Column 3 is the same as column 2 except for the negative input. Columns 4 and 5 are similar to columns 2 and 3 except a positive differential pulse is transmitted.

Columns 6 to 9 is similar to columns 2 to 5 except both the transmitter and receiver are running the (DC) EXTEST command.

While it is not possible to identify precisely which fault is occurring based on the fault signature, the signature to the no fault condition is unique when the (DC) EXTEST command is run with at least one of the EXTEST\_TRAIN or EXTEST\_PULSE commands. Running only AC-JTAG commands is not sufficient since the no fault condition signature is not distinguishable from the Tx to Rx short (see shaded cells in Table 38).

**Figure 12: AC-Coupled Connection**

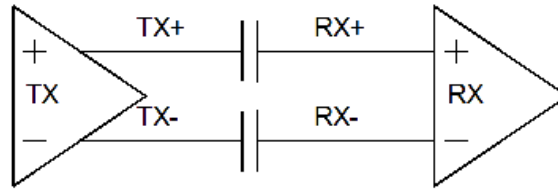

**Table 38: AC-Coupled Connection Fault Signature**

| DC-Coupled Fault    | AC Testing Sample 0 |              | AC Testing Sample 1 |              | (DC) EXTEST Sample 0 |              | (DC) EXTEST Sample 1 |              |
|---------------------|---------------------|--------------|---------------------|--------------|----------------------|--------------|----------------------|--------------|
|                     | Positive Leg        | Negative Leg | Positive Leg        | Negative Leg | Positive Leg         | Negative Leg | Positive Leg         | Negative Leg |
| TX+ Open            | 0                   | X            | 0                   | X            | 1                    | X            | 1                    | X            |
| TX- Open            | X                   | 0            | X                   | 0            | X                    | 1            | X                    | 1            |
| RX+ Open            | 0                   | X            | 0                   | X            | 1                    | X            | 1                    | X            |
| RX- Open            | X                   | 0            | X                   | 0            | X                    | 1            | X                    | 1            |
| TX+ short to power  | 0/Note 2            | X            | 0/Note 2            | X            | 1                    | X            | 1                    | X            |
| TX- short to power  | X                   | 0/Note 2     | X                   | 0/Note 2     | X                    | 1            | X                    | 1            |
| RX+ short to power  | 0/Note 2            | X            | 0/Note 2            | X            | 1                    | X            | 1                    | X            |
| RX- short to power  | X                   | 0/Note 2     | X                   | 0/Note 2     | X                    | 1            | X                    | 1            |
| TX+ short to ground | 0                   | X            | 0                   | X            | 1                    | X            | 1                    | X            |
| TX- short to ground | X                   | 0            | X                   | 0            | X                    | 1            | X                    | 1            |
| RX+ short to ground | 0                   | X            | 0                   | X            | 0                    | X            | 0                    | X            |
| RX- short to ground | X                   | 0            | X                   | 0            | X                    | 0            | X                    | 0            |
| TX+ short to TX-    | Note 1              | Note 1       | Note 1              | Note 1       | 1                    | 1            | 1                    | 1            |
| RX+ short to RX-    | Note 1              | Note 1       | Note 1              | Note 1       | 1                    | 1            | 1                    | 1            |
| TX+ short to RX-    | X                   | 0            | X                   | 1            | X                    | 0            | X                    | 1            |

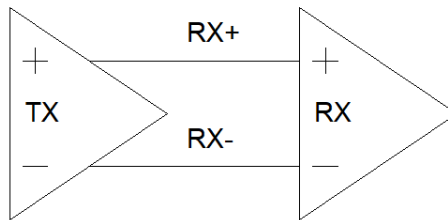

**Table 38: AC-Coupled Connection Fault Signature (Continued)**

| DC-Coupled Fault | AC Testing Sample 0  |              | AC Testing Sample 1 |              | (DC) EXTEST Sample 0 |              | (DC) EXTEST Sample 1 |              |
|------------------|--|--------------|---------------------|--------------|----------------------|--------------|----------------------|--------------|
|                  | Positive Leg   | Negative Leg | Positive Leg        | Negative Leg | Positive Leg         | Negative Leg | Positive Leg         | Negative Leg |
| TX- short to RX+ | 1  | X            | 0                   | X            | 1                    | X            | 0                    | X            |
| TX+ short to RX+ | 0  | X            | 1                   | X            | 0                    | X            | 1                    | X            |
| TX- short to RX- | X  | 1            | X                   | 0            | X                    | 1            | X                    | 0            |
| No Fault         | 0  | 1            | 1                   | 0            | 1                    | 1            | 1                    | 1            |
| Note 1           | Short on positive and negative leg can have several behavior on the test receiver. If both drivers cancel each other out, then output on both legs is 0. If one driver dominates the other driver, then both legs are either both 1 or both 0. In any case, the result is that both legs will have the same value. |              |                     |              |                      |              |                      |              |
| Note 2           | A solid short to power is assumed. If the short has high inductance, then a pulse may still be sent at the receiver and will be mistaken as a good connection.   |              |                     |              |                      |              |                      |              |

The fault detection across DC-coupled connections can be detected with any one of the AC-JTAG or (DC) EXTEST commands. The DC-coupled connection is shown in [Figure 13](#). The fault signature is shown in [Table 39](#).

**Figure 13: DC-Coupled Connection**



**Table 39: DC-Coupled Connection Fault Signature**

| DC-Coupled Fault    | AC Testing Sample 0 |              | AC Testing Sample 1 |              | (DC) EXTEST Sample 0 |              | (DC) EXTEST Sample 1 |              |
|---------------------|---------------------|--------------|---------------------|--------------|----------------------|--------------|----------------------|--------------|
|                     | Positive Leg        | Negative Leg | Positive Leg        | Negative Leg | Positive Leg         | Negative Leg | Positive Leg         | Negative Leg |
| RX+ Open            | 0                   | X            | 0                   | X            | 1                    | X            | 1                    | X            |
| RX- Open            | X                   | 0            | X                   | 0            | X                    | 1            | X                    | 1            |
| RX+ short to power  | 0/Note 2            | X            | 0/Note 2            | X            | 1                    | X            | 1                    | X            |
| RX- short to power  | X                   | 0/Note 2     | X                   | 0/Note 2     | X                    | 1            | X                    | 1            |
| RX+ short to ground | 0                   | X            | 0                   | X            | 0                    | X            | 0                    | X            |
| RX- short to ground | X                   | 0            | X                   | 0            | X                    | 0            | X                    | 0            |



**Table 39: DC-Coupled Connection Fault Signature**

| DC-Coupled Fault | AC Testing Sample 0   |              | AC Testing Sample 1 |              | (DC) EXTEST Sample 0 |              | (DC) EXTEST Sample 1 |              |
|------------------|---|--------------|---------------------|--------------|----------------------|--------------|----------------------|--------------|
|                  | Positive Leg  | Negative Leg | Positive Leg        | Negative Leg | Positive Leg         | Negative Leg | Positive Leg         | Negative Leg |
| RX+ short to RX- | Note 1  | Note 1       | Note 1              | Note 1       | Note 1               | Note 1       | Note 1               | Note 1       |
| No Fault         | 0   | 1            | 1                   | 0            | 0                    | 1            | 1                    | 0            |
| Note 1           | Short on positive and negative leg can have several behaviors on the test receiver. If both drivers cancel each other out, then output on both legs is 0. If one driver dominates the other driver, then both legs are either both 1 or both 0. In any case, the result is that both legs will have the same value. |              |                     |              |                      |              |                      |              |
| Note 2           | A solid short to power is assumed. If the short has high inductance, then a pulse may still be sent at the receiver and will be mistaken as a good connection.  |              |                     |              |                      |              |                      |              |



## 3.11 Reference Clock

The 88E2010/88E2040L device can use a 50 MHz or 156.25 MHz differential clock into CLKP/N or a 50 MHz crystal as the reference clock.

The device can use one of three clocking options as shown in [Table 40](#). CLK\_SEL must be stable and the selected clock toggling prior to de-assertion of RESETn. CLK\_SEL must not change value for the duration of device operation.

**Table 40: Reference Clock Options**

| CLK_SEL[1:0] | XTAL1/XTAL2 | CLKP/CLKN  |
|--------------|-------------|------------|
| 00           | 50 MHz      | Floating   |
| 01           | GND         | 50 MHz     |
| 10           | GND         | 156.25 MHz |
| 11           | Reserved    | Reserved   |



**Note**

50 MHz crystal operation is only supported for commercial-grade devices.

## 3.12 Power Supplies

The 88E2010/88E2040L device requires the following power supplies: AVDDT, AVDDL, AVDDH, DVDD, and VDDO.

### 3.12.1 AVDDL

AVDDL is the copper transmitter and receiver 1.5V analog supply.

### 3.12.2 AVDDH

AVDDH is the copper transmitter and receiver 1.8V or 2.0V analog supply.

### 3.12.3 AVDDT

AVDDT is the copper transmitter 2.3V or 2.5V analog supply.

### 3.12.4 AVDDC

AVDDC is the common analog supply of 1.5V.

### 3.12.5 AVDDS

AVDDS is the SERDES analog supply of 1.5V.

### 3.12.6 AVDDR

AVDDR is the regulator supply and should be tied to 1.5V.

### 3.12.7 DVDD

DVDD is the core logic 0.8V or 0.88V digital supply. (0.88V for I-grade only)

### 3.12.8 VDDO

There are four separate VDDO segments (VDDOT, VDDOR, VDDOL, and VDDOM). Each segment can be independently set to one for the following voltages: 1.5V, 1.8V, 2.5V, or 3.3V, except VDDOM that can also support 1.2V. Each VDDO segment has a corresponding voltage select configuration pin (VSEL\_T, VSEL\_R, VSEL\_L, and VSEL\_M). [Table 41](#) lists the signals under each of the VDDO segments.

If the VDDO\* segment is set to 1.2V, 1.5V, or 1.8V, then its corresponding VSEL\_\* should be tied to VDDO\*.

If the VDDO\* segment is set to 2.5V, or 3.3V, then its corresponding VSEL\_\* should be tied to VSS.

The input pins are not high voltage tolerant. For example, if VDDOR is tied to 2.5V, then RESETn should not be driven to 3.3V.

**Table 41: Signal Power Segment**

| Power Segment  | VDDOT  | VDDOR     | VDDOL        | VDDOM     |
|----------------|--------|-----------|--------------|-----------|
| Voltage Select | VSEL_T | VSEL_R    | VSEL_L       | VSEL_M    |
| <b>Signals</b> | TCK    | GPIO[x:0] | CLK_SEL[1:0] | INTn      |
|                | TDI    | RCLK0     | CONFIG[7:0]  | MDC[x:0]  |
|                | TDO    | RCLK1     | LED0[3:0]    | MDIO[x:0] |
|                | TMS    | RESETn    |              | TEST      |
|                | TRST   | SPI_CLK   |              |           |
|                |        | SPI_MOS0  |              |           |
|                |        | SPI_MOS1  |              |           |
|                |        | SPI_SSn   |              |           |

### 3.12.9 VHV

The VHV pin is a test pin and should be left floating during normal operation.

### 3.12.10 VDD09

VDD09 is the 0.9V internally generated regulated output and these pins should be tied to an external 0.22  $\mu$ F capacitor to VSS.

# 4 Copper Unit (T Unit)

This section describes the copper unit (T Unit) interface functions.

## 4.1 Media Interface

The copper interface consists of the MDIP/N[3:0] pins that connect to the physical media for 5GBASE-T, 2.5GBASE-T, 1000BASE-T, 100BASE-TX, and 10BASE-T modes of operation.

The device integrates MDI interface termination resistors. The IEEE 802.3 specification requires that both sides of a link have termination resistors to prevent reflections. Traditionally, these resistors and additional capacitors are placed on the board between a PHY device and the magnetics. The resistors must be very accurate to meet the strict IEEE return loss requirements. Typically,  $\pm 1\%$  accuracy resistors are used on the board. These additional components between the PHY and the magnetics complicate board layout. Integrating the resistors has many advantages including component cost savings, better ICT yield, board reliability improvements, board area savings, improved layout, and signal integrity improvements. See the *Benefits of Integrating Termination Resistors for Ethernet Application Note* for details.

The transmitter can be shut down in all operational speeds by setting register 3.8109.0 to 1 in 10M/100M/1G operation and register 1.0009.0 to 1 for 2.5G/5G operation.

Each channel's transmitter's polarity can be reversed by setting the corresponding bit in register 3.8001.3:0 to 1 in 10M/100M/1G operation. Channel transmitter polarity reversal is not supported for 2.5G/5G operation. The devices support Auto-MDI/MDIX to automatically switch to the proper configuration when a cable is connected.

### 4.1.1 2.5GBASE-T and 5GBASE-T

Figure 14: 2.5GBASE-T and 5GBASE-T Data Path

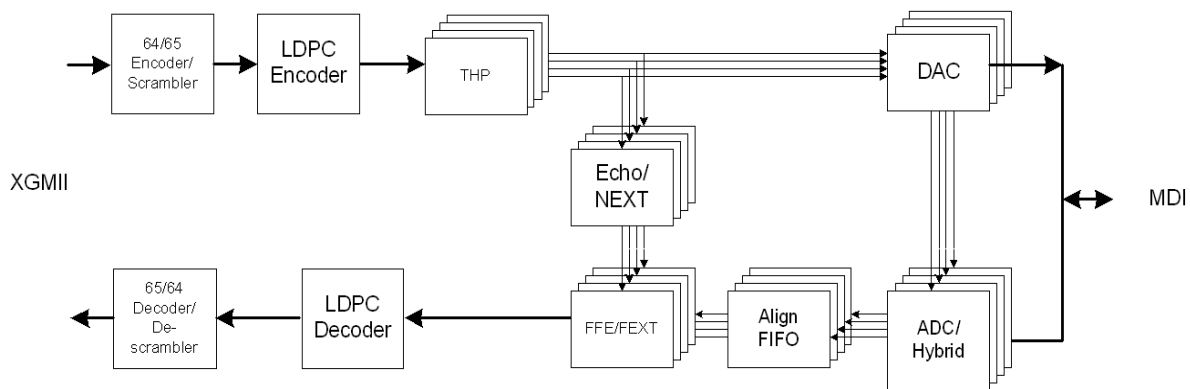

The device performs all the physical layer functions of 2.5GBASE-T and 5GBASE-T over a CAT 5e, 6A, and 7 cable system. The device performs scrambling, LDPC coding, PAM16 mapping, and THP pre-coding on the transmit side with adaptive equalization, full echo cancellation, decoding and de-scrambling on the receive side. It is fully compliant to the IEEE 802.3 standard, including the PMA and PCS sublayers for full physical layer functionality.



### 4.1.2 1000BASE-T

Figure 15: 1000BASE-T Data Path

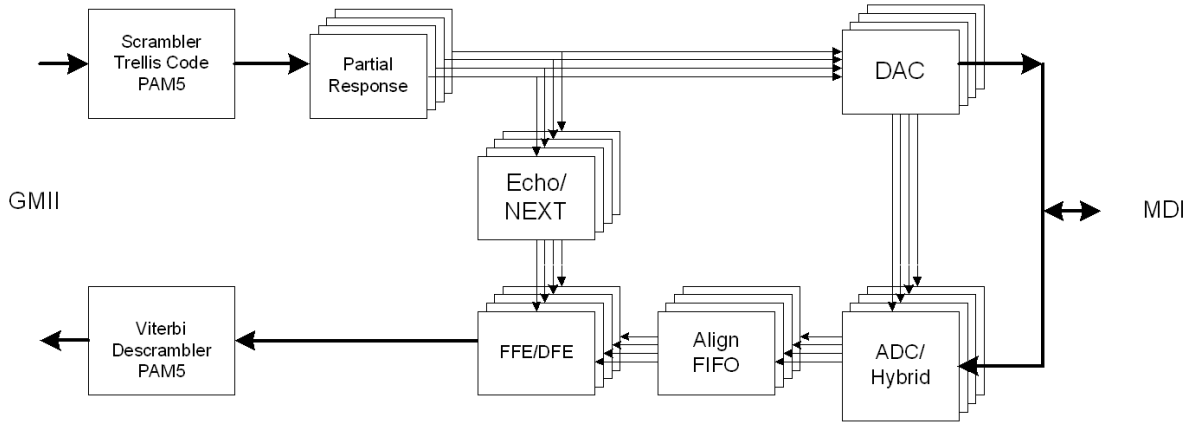

The device performs all the physical layer functions of 1000BASE-T full or half duplex on twisted pair CAT 5, 6, and 7 cable. It is fully compliant to the IEEE 802.3 standard, including the PMD, PMA, and PCS sublayers. The device, for 1000BASE-T, performs scrambling, Trellis coding, PAM5 mapping functions on the transmit side with adaptive equalization, echo cancellation, viterbi decoding and de-scrambling on the receive side.

### 4.1.3 100BASE-TX

Figure 16: 100BASE-TX Data Path

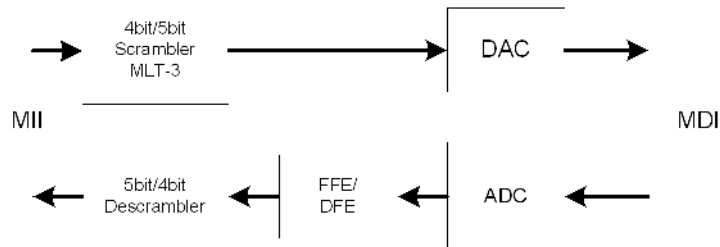

The device performs all the physical layer functions of 100BASE-TX full or half duplex on twisted pair CAT 5, 6, and 7 cable. It is fully compliant to the IEEE 802.3 standard, including the PMD, PMA, and PCS sublayers. The device supports Auto-MDI/MDIX to automatically switch to the proper configuration once a cable is connected. As mentioned, the device also integrates the PHY termination resistors enabling BOM material and cost savings, ease of board layout, and bettered signal integrity.

## 4.1.4 10BASE-T

Figure 17: 10BASE-T Data Path

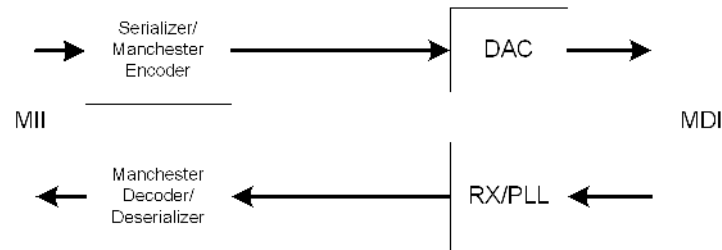

The device additionally performs all the physical layer functions of 10BASE-T full or half duplex on twisted pair cable. It is compliant to the IEEE 802.3 standard, including the PMD, PMA, and PCS sublayers.

## 4.1.5 Taking Down the Link

### 4.1.5.1 Taking Down the Link in 5GBASE-T/2.5GBASE-T Modes

When the link is established, the link monitor algorithm will detect conditions where a retrain is required, such as the link partner has dropped the link or the link quality has dropped below acceptable levels.

The PHY supports fast retrain defined for 2.5G/5GBASE-T in IEEE 802.3bz-2016. The PHY also supports a Negotiated Fast Retrain defined for pre-standard devices. If the local device and the link partner have negotiated fast retrain support and the link quality has dropped below operating conditions, then the PHY will enter fast retrain in coordination with the link partner and return to normal operation within the defined fast retrain duration. If the PHY fails to achieve acceptable link quality or the fast retrain process fails, then the PHY will drop the link and return to normal training.

When fast retrain is not negotiated and the link quality has dropped below operating conditions, the PHY will perform a retrain as defined in IEEE Std. 802.3an-2006. Upon a failure to retrain, the PHY will return to Auto-Negotiation.

### 4.1.5.2 Taking Down the Link in 1000BASE-T Mode

The link is established when both sides so indicate. Each side continues sending idle symbols whenever it has no data to transmit. The link is maintained as long as valid idle, data, or carrier extension symbols are received.

### 4.1.5.3 Taking Down the Link in 100BASE-TX Mode

For 100BASE-TX links, the PHY devices and its link partner begin transmitting idle symbols after completion of the Auto-Negotiation process. Each side continues sending idle symbols whenever it has no data to transmit. The link is maintained as long as valid idle symbols or data are received.

The PHY devices take down an established link when the required conditions are no longer met. When a link is down, data transmission stops.

For 100BASE-TX and 1000BASE-T links, taking down a link occurs after valid idle codes are no longer received. After the link is down, if Auto-Negotiation is enabled, then the PHY devices reenter the Auto-Negotiation phase and begin transmitting FLPs.

## 4.2 Loopback

The T Unit implements multiple loopback paths.



### 4.2.1 MAC Loopback

The T Unit can loop back data from the internal XGMII/GMII/MII bus by setting register 3.0000.14 to 1 for all modes. In 10/100/1000 loopback mode, the data received from the internal GMII/MII bus is not transmitted on the media interface and the link will be dropped. In 2.5G/5G loopback mode, the link will remain active and data from the internal XGMII bus will be transmitted on to the media interface.

If Auto-Negotiation and loopback are enabled, then FLP Auto-Negotiation codes will be transmitted. If the T Unit is in forced 10BASE-T mode and loopback is enabled, then 10BASE-T idle link pulses will be transmitted on the media interface. If the T Unit is in forced 100BASE-T mode and loopback is enabled, then 100BASE-T idles will be transmitted on the media interface.

When MAC loopback is enabled, the loopback speed will be the active link speed of the T Unit. If the link is down, then the loopback speed will be determined by register 31.F000.7:6.

**Figure 18: MAC Interface Loopback Diagram — Copper Media Interface**

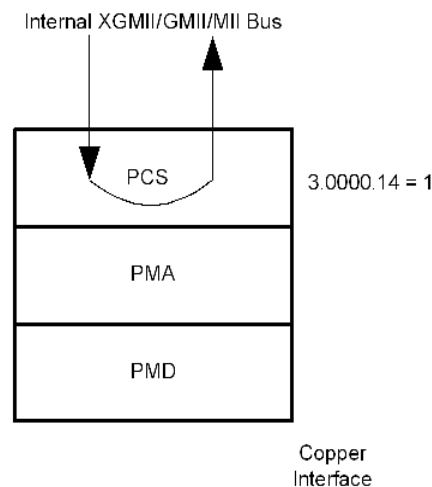

### 4.2.2 Line Loopback

Line loopback allows a link partner to send frames into the media interface to test the transmit and receive data paths. Frames from a link partner into the PHY bus are looped back and sent out on the line before reaching the internal XGMII/GMII/MII. They are also sent to the internal XGMII/GMII/MII bus. The packets received from the internal XGMII/GMII/MII bus are ignored during line loopback. This allows the link partner to receive its own frames.

Before enabling the line loopback feature, the PHY must first establish link to another PHY link partner. If Auto-Negotiation is enabled, then both link partners should advertise the same speed and full duplex. If Auto-Negotiation is disabled, then both link partners must be forced to the same speed and full duplex. When link is established, the line loopback mode can be enabled setting register 3.8002.5 to 1 for 10M/100M/1G modes and 1.C000.11 to 1 for 2.5G/5G mode.

If MAC loopback 3.0000.14 is set to 1, then the line loopback registers 3.8002.5 and 1.C000.11 are ignored.



Figure 19: Line Loopback Diagram — Copper Media Interface

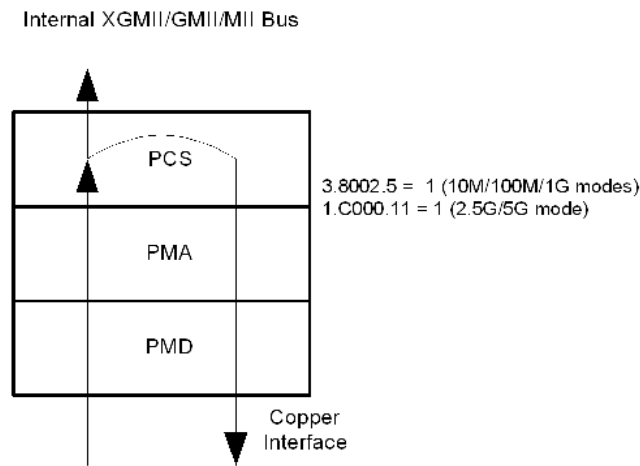

## 4.3 Power Management

The T Unit supports several advanced power management modes that conserve power.

### 4.3.1 Manual Power Down

The T Unit can be manually powered down by setting register 1.0000.11 or 3.0000.11 to 1. In general, this bit should not be set unless there is a need to only power down the T Unit.

When the device is operating in modes that does not require the T Unit to be operational, the T Unit will be powered down automatically regardless of the setting in register 1.0000.11 or 3.0000.11.

### 4.3.2 Energy Detect

The T Unit can be placed in energy detect power down modes by selecting either of the two Energy Detect modes. Both modes enable the PHY to wake up on its own by detecting activity on the media interface. The status of the Energy Detect is reported in register 3.8008.4 and the Energy Detect changes are reported in register 3.8011.4.

#### 4.3.2.1 Energy Detect (Mode 1)

Energy Detect (Mode 1) is entered by setting register 3.8000.9:8 to 10.

In Mode 1, only the signal detection circuitry and register are active. If the PHY detects energy on the line, then it starts to Auto-Negotiate sending FLPs for 5 seconds. If at the end of 5 seconds the Auto-Negotiation is not completed, then the PHY stops sending FLPs and goes back to monitoring receive energy. If Auto-Negotiation is completed, then the PHY goes into normal operation. If during normal operation the link is lost, the PHY will restart Auto-Negotiation. If no energy is detected after 5 seconds, then the PHY resumes monitoring receive energy.



#### 4.3.2.2 Energy Detect +™ (Mode 2)

Energy Detect (Mode 2) is entered by setting register 3.8000.9:8 to 11.

In Mode 2, the PHY sends out a single 10 Mbps Normal Link Pulse (NLP) every one second. Except for this difference, Mode 2 is identical to Mode 1 operation. If the T Unit is in Mode 1, then it cannot wake up a connected device; so, the connected device must be transmitting NLPs or either device must be woken up through register access. If the T Unit is in Mode 2, then it can wake a connected device.

## 4.4 Auto-Negotiation

The PHY supports IEEE 802.3 Clauses 28, 40, and 55 Auto-Negotiation. The PHY also supports proprietary extensions to the Auto-Negotiation protocol.

### 4.4.1 802.3 Clause 28, 40, and 55 Auto-Negotiation

The 10/100/1000/2.5G/5GBASE-T Auto-Negotiation (AN) is based on Clauses 28, 40, 55, and 126 of the IEEE 802.3 specification. It is also based on the NBASE-T Physical Layer Specification. It is used to negotiate speed, duplex, and flow control. When Auto-Negotiation is initiated, the PHY determines whether the remote device has Auto-Negotiation capability: if so, the PHY and the remote device negotiate the speed and duplex with which to operate.

If the remote device does not have Auto-Negotiation capability, then the PHY uses the parallel detect function to determine the speed of the remote device for 100BASE-TX and 10BASE-T modes. If link is established based on the parallel detect function, then it is required to establish link at half-duplex mode only. Refer to IEEE 802.3 Clauses 28, 40, 55, and 126 for a full description of Auto-Negotiation.

The 10/100/1000/2.5G/5GBASE-T Auto-Negotiation can be enabled and disabled via register 7.0000.12. Auto-Negotiation must be enabled if the PHY is intended to operate in 1000BASE-T, 2.5GBASE-T, or 5GBASE-T. Furthermore, the extended next page control bit (7.0000.13) must also be set to 1 if the PHY is intended to operate in 2.5GBASE-T and 5GBASE-T.

Auto MDI/MDIX and Auto-Negotiation may be disabled and enabled independently.

When Auto-Negotiation is disabled, the speed and duplex can be set via registers 1.0000.13, 1.0000.6, and 7.8000.4, respectively. Changes to any of these bits will take effect immediately when Auto-Negotiation is disabled.

When Auto-Negotiation is enabled the abilities that are advertised can be changed via registers 7.0010, 7.0020, and 7.8000.9:8. Changes to these registers do not take effect upon a copper link drop, changes take effect only after one of the following occurs:

- Software reset (1.0000.15, 3.0000.15, or 7.0000.15).
- Restart Auto-Negotiation (7.0000.9).
- Transition from power down to power up (1.0000.11 or 3.0000.11).
- Auto-Negotiation Enable bit toggles (7.0000.12).
- Extended Next Page Enable bit toggles (7.0000.13).
- Speed and Duplex toggles while Auto-Negotiation is disabled (1.0000.13, 1.0000.6, and 7.8000.4).

Registers 7.0010, 7.0020, and 7.8000.9:8 are internally latched once every time the Auto-Negotiation enters the Ability Detect state in the arbitration state machine only following one of the previously listed events. So a write into registers 7.0010, 7.0020, and 7.8000.9:8 has no effect when the PHY begins to transmit Fast Link Pulses (FLPs). This guarantees that sequences of FLPs transmitted are consistent with one another.

If 1000BASE-T, 2.5GBASE-T, or 5GBASE-T modes are advertised, then the PHY automatically sends the appropriate next pages or extended next page to advertise the capability and negotiate master/slave mode of operation. If the user does not select to transmit additional next pages or extended next pages, then the next page bit (7.0010.15) can be set to zero (default) and no further action is required from the user.

If either next pages or extended next pages are required in addition to those selected, or 1000BASE-T, 2.5GBASE-T, or 5GBASE-T, then the user can set register 7.0010.15 to one. Additional next pages can be transmitted and received via registers 7.0016 and 7.0019, respectively. Additional extended next pages can be transmitted and received via registers 7.0016, 7.0017, 7.0018 and 7.0019, 7.001A, and 7.001B, respectively.

1000BASE-T next page exchanges 2.5GBASE-T and 5GBASE-T extended next page exchanges are automatically handled by the PHY without user intervention, regardless of whether additional next pages are sent.

When the PHY completes Auto-Negotiation, it updates the various status in registers 7.0001, 7.0013, 7.8000, and 7.8001. Various Auto-Negotiation statuses such as speed, duplex, page received, and so on are also available in registers 3.8008 and 3.8011.

Clause 45 defines a 16-bit address space and protocol for 10G PHY management registers. The device supports the Clause 45 protocol and address space. Some of the 10M/100M/1G management register bits have an



equivalent defined by IEEE 802.3 within the Clause 45 address space. However, there are also 10M/100M/1G management registers that are not defined by IEEE 802.3 within the Clause 45 address space. In the device these management register bits are mapped into 7.8000, 7.8001, and 7.8002.

The changes in Auto-Negotiation settings via MDIO registers will not take into effect (including a link down event) until Auto-Negotiation restart is initiated.

#### 4.4.2 Exchange Complete — No Link Indicator

Sometimes when link does not come up, it is difficult to determine whether the failure is due to the Auto-Negotiation FLP not completing or from the 10/100/1000/2.5G/5GBASE-T link not being able to come up.

Register 3.8011.3 is a latched high bit that gets set to 1 whenever the FLP exchange is completed but the link cannot be established for some reason. When the bit is set, it can be cleared only by reading the register.

This bit will not be set if the FLP exchange is not completed or if link is established.

### 4.5 Auto Downshift

The auto downshift feature will downshift to the next highest available speed when a link fails to be established after several attempts to link. Failure to link can be caused by cabling issues such as using long CAT 5 cabling for 5GBASE-T or using cable with two twisted pairs instead of four twisted pairs. In either of the case, the Auto-Negotiation will repeatedly negotiate to the higher speed but fail to link.

With the NBASE-T downshift feature enabled, the T Unit is able to Auto-Negotiate with another link partner using cable pairs 1, 2 and 3, 6 to downshift, and link to the next highest advertised speed common between the two PHYs.

By default, the downshift feature is enabled. Setting register 1.C034.4 to 0 will disable the auto downshift feature.

Registers 1.C034 and 1.C035 specify the amount of attempts to link to 5GBASE-T, 2.5GBASE-T, and 1000BASE-T, respectively before down shifting to the next highest available speed. The number of attempts before downshift is (1.C034.[3:0]+1). So the default setting of 2 means NBASE-T downshift occurs after 3 link failures at current resolved speed. During the process of NBASE-T downshift, the number of attempts already performed is shown in the status register 1.C035.[12:9] which gets reset at next link up. Downshift for 100BASE-T and 10BASE-T are not supported.

When the lowest available speed fails to link after the programmed number of attempts, the PHY will restart the algorithm and attempt to link at the highest available speed.

## 4.6 Auto MDI/MDIX Crossover

The T Unit automatically determines whether it must cross over between pairs as shown in [Table 42](#) so that an external crossover cable is not required. If the T Unit interoperates with a device that cannot automatically correct for crossover, the T Unit makes the necessary adjustment prior to commencing Auto-Negotiation. If the T Unit interoperates with a device that implements MDI/MDIX crossover, then a random algorithm as described in IEEE 802.3 Clause 40.4.4 determines which device performs the crossover.

When the T Unit interoperates with legacy 10BASE-T devices that do not implement Auto-Negotiation, the T Unit follows the same algorithm as previously described since link pulses are present. However, when interoperating with legacy 100BASE-TX devices that do not implement Auto-Negotiation (such as when link pulses are not present), the T Unit uses signal detect to determine whether to crossover.

The auto MDI/MDIX crossover function can be disabled via register 3.8000.6:5.

The pin mapping in MDI and MDIX modes is shown in [Table 42](#).

**Table 42: Media Dependent Interface Pin Mapping**

| Pin       | MDI                    |            |          | MDIX                   |            |          |
|-----------|------------------------|------------|----------|------------------------|------------|----------|
|           | 1000/2.5G/<br>5GBASE-T | 100BASE-TX | 10BASE-T | 1000/2.5G/<br>5GBASE-T | 100BASE-TX | 10BASE-T |
| MDIP/N[0] | BI_DA±                 | TX±        | TX±      | BI_DB±                 | RX±        | RX±      |
| MDIP/N[1] | BI_DB±                 | RX±        | RX±      | BI_DA±                 | TX±        | TX±      |
| MDIP/N[2] | BI_DC±                 | unused     | unused   | BI_DD±                 | unused     | unused   |
| MDIP/N[3] | BI_DD±                 | unused     | unused   | BI_DC±                 | unused     | unused   |



**Note**

[Table 42](#) assumes no crossover on PCB.

The MDI/MDIX status is indicated by register 3.8008.6. This bit indicates whether the signal pairs (3, 6) and (1, 2) are crossed over. In 5GBASE-T, 2.5GBASE-T, and 1000BASE-T operation, the device can also correct for crossover between pairs (4, 5) and (7, 8). However, this is not indicated by register 3.8008.6.



## 4.7 Auto Polarity Correction

The T Unit automatically corrects polarity errors on the receive pairs in 5GBASE-T, 2.5GBASE-T, 1000BASE-T and 10BASE-T modes. In 100BASE-TX mode, the polarity does not matter.

In 5GBASE-T, 2.5GBASE-T, and 1000BASE-T modes, auto polarity correction is always enabled, receive polarity errors are automatically corrected based on the startup training sequence. When the training is complete the polarity is locked on all pairs. The polarity becomes unlocked only when the receiver loses lock.

If a 1000BASE-T, 2.5GBASE-T, or 5GBASE-T link is established, register 1.0082.11:8 (2.5G/5G) and 3.8182.11:8 (1G) report the polarity on all 4 pairs.

In 10BASE-T mode, auto polarity correction is enabled when register 3.8000.1 is set to 0. If register 3.8000.1 is set to 1, then the polarity will be forced to normal. When enabled, polarity errors are corrected based on the detection of validly spaced link pulses. The detection begins during the MDI crossover detection phase and locks when the 10BASE-T link is up. The polarity becomes unlocked when link is down.

The 10BASE-T polarity correction status is indicated by register 3.8008.1. This bit indicates whether the receive pair (3, 6) is polarity reversed in MDI mode of operation. In the MDIX mode of operation, the receive pair is (1, 2) and register 3.8008.1 indicates whether this pair is polarity reversed. Although all pairs are corrected for receive polarity reversal, register 3.8008.1 only indicates polarity reversal on the pairs described above.

The 10BASE-T receive polarity can be forced to negative by setting register 3.8001.9 to 1. This is useful for debugging and should not be used during normal operation.

# 5

## Host Interface Unit (H Unit)

The host side interface comprises two differential input lanes SIP[1:0]/SIN[1:0] and two differential output lanes SOP[1:0]/SON[1:0]. They are designed to operate over short backplanes to the host device.

These lanes can be arranged to form SGMII, 1000BASE-X, 2500BASE-X, and 5GBASE-R.

### 5.1 Host Electrical Interface

The input and output buffers of the SERDES interface are internally terminated by 50Ω impedance (100Ω differential). No external terminations are required.

The SERDES transmitter has a three-tap (1 pre-tap and 1 post-tap) FIR filter for channel equalization. The FIR tap can be manually adjusted to optimize the transmit eye over a particular channel.

The receiver performs clock and data recovery and de-serializes the data.

The polarity of the H Unit inputs and outputs can be inverted.

- 4.F004.15 inverts Lane3 input polarity: 0 = Normal, 1 = Invert
- 4.F004.14 inverts Lane2 input polarity: 0 = Normal, 1 = Invert
- 4.F004.13 inverts Lane 1 input polarity: 0 = Normal, 1 = Invert
- 4.F004.12 inverts Lane 0 input polarity: 0 = Normal, 1 = Invert
- 4.F004.11 inverts Lane3 output polarity: 0 = Normal, 1= Invert
- 4.F004.10 inverts Lane2 output polarity: 0 = Normal, 1= Invert
- 4.F004.9 inverts Lane 1 output polarity: 0 = Normal, 1 = Invert
- 4.F004.8 inverts Lane 0 output polarity: 0 = Normal, 1 = Invert



**Note**

Lane 1 is only applicable when MACTYPE[2:0] = 000, 001, 010, or 011. See [Section 3.4, Configuration and Resets, on page 65](#) for MACTYPE[2:0] configuration details.



## 5.2 PCS

The Host Interface supports several different PCS. Register 31.F001.2:0 determines the behavior of the host interface as shown in [Table 43](#) and [Table 44](#).

**Table 43: 88E2010 Host Interface Configuration**

| 31.F001.2:0 | Line Rate           |            |                            |          |         |
|-------------|---------------------|------------|----------------------------|----------|---------|
|             | 5 Gbps              | 2.5 Gbps   | 1 Gbps                     | 100 Mbps | 10 Mbps |
| 000         | 5GBASE-R            | 2500BASE-X | SGMII Auto-Negotiation On  |          |         |
| –           | Reserved            |            |                            |          |         |
| –           | Reserved            |            |                            |          |         |
| 011         | 5GBASE-R            | 2500BASE-X | SGMII Auto-Negotiation On  |          |         |
| 100         | 5GBASE-R            | 2500BASE-X | SGMII Auto-Negotiation On  |          |         |
| 101         | 5GBASE-R            | 2500BASE-X | SGMII Auto-Negotiation Off |          |         |
| 110         | 5GBASE-R/2500BASE-X |            |                            |          |         |
| 111         | Reserved            |            |                            |          |         |

**Table 44: 88E2040L Host Interface Configuration**

| 31.F001.2:0 | Line Rate           |            |                            |          |         |
|-------------|---------------------|------------|----------------------------|----------|---------|
|             | 5 Gbps              | 2.5 Gbps   | 1 Gbps                     | 100 Mbps | 10 Mbps |
| 000         | 5GBASE-R            | 2500BASE-X | SGMII Auto-Negotiation On  |          |         |
| 001         | 5GBASE-R            | 2500BASE-X | SGMII Auto-Negotiation Off |          |         |
| 010         | Reserved            |            |                            |          |         |
| 011         | Reserved            |            |                            |          |         |
| 100         | 5GBASE-R            | 2500BASE-X | SGMII Auto-Negotiation On  |          |         |
| 101         | 5GBASE-R            | 2500BASE-X | SGMII Auto-Negotiation Off |          |         |
| 110         | 5GBASE-R/2500BASE-X |            |                            |          |         |
| 111         | Reserved            |            |                            |          |         |

### 5.2.1 5GBASE-R/2500BASE-X

The 5GBASE-R/2500BASE-X PCS is enabled by setting register 31.F001.2:0 = 001 (88E2010 only), 010, 110, or 111.

The 5GBASE-R/2500BASE-X PCS operates according to Clause 49 of the IEEE 802.3ae specification. The PCS uses a 64B/66B coding and scrambling to improve the transmission characteristics of the serial data and ease clock recovery at the receiver. The synchronization headers for 64B/66B code enable the receiver to achieve block alignment on the receive data. For further details, refer to the IEEE 802.3 specification.

### 5.2.2 5GBASE-R

For the 88E2040L devices, the 5GBASE-R PCS is enabled by setting register 31.F001.2:0 = 000, 001, 100, 101, and the line rate is 5 Gbps.

For the 88E2010 device, the 5GBASE-R PCS is enabled by setting register 31.F001.2:0 = 000, 011, 100, 101, and the line rate is 5 Gbps.



5GBASE-R is identical to 5GBASE-R/2500BASE-X as described in [Section 5.2.1, 5GBASE-R/2500BASE-X](#) except at 50% speed.

### 5.2.3 2500BASE-X

For the 88E2040L device the 2500BASE-X PCS is enabled by setting register 31.F001.2:0 = 000, 001, 100, 101, and the line rate is 2.5 Gbps.

For the 88E2010 device, the 2500BASE-X PCS is enabled by setting register 31.F001.2:0 = 000, 011, 100, 101, and the line rate is 2.5 Gbps.

2500BASE-X is identical to 1000GBASE-X operation as described in [Section 5.2.4.1, PCS](#) except at 2.5 times the speed. Auto-Negotiation is not supported in 2500BASE-X.

### 5.2.4 SGMII (Media)

For the 88E2040L device, the SGMII is enabled by setting register 31.F001.2:0 = 000, 001, 100, 101, and the line rate is 10/100/1000 Mbps. SGMII Auto-Negotiation is enabled with the 000 and 100 settings.

For the 88E2010 device, the SGMII is enabled by setting register 31.F001.2:0 = 000, 011, 100, 101, and the line rate is 10/100/1000 Mbps. SGMII Auto-Negotiation is enabled with the 000, 011 and 100 settings.

#### 5.2.4.1 PCS

The 1000BASE-X PCS operates according to Clause 36 of the IEEE 802.3 specification. The PCS uses a 8/10 bit coding for DC line balancing. For further details, refer to the IEEE 802.3 specification.

The SGMII protocol is also supported over 1000BASE-X. The SGMII allows 10 Mbps, 100 Mbps, and 1000 Mbps throughput over 1000BASE-X line coding.

When SGMII Auto-Negotiation is turned off (4.2000.12 = 0), the speed setting is programmed via register 4.2000 bits 13 and 6. Link is established when the underlying 1000BASE-X establishes link.

When SGMII Auto-Negotiation is turned on (4.2000.12 = 1), the SGMII is set to the speed of the line interface. This speed capability is advertised and Auto-Negotiation has to complete prior to link being established.



### 5.2.4.2 SGMII Auto-Negotiation

SGMII is a de-facto standard designed by Cisco. SGMII uses 1000BASE-X coding to send data as well as Auto-Negotiation information between the PHY and the MAC. However, the contents of the SGMII Auto-Negotiation are different than the 1000BASE-X Auto-Negotiation. See the *Cisco SGMII Specification* and the *MAC Interfaces and Auto-Negotiation Application Note* for further details.

The device supports SGMII interface with and without Auto-Negotiation. Auto-Negotiation can be enabled or disabled by writing to register 4.2000.12. If SGMII Auto-Negotiation is disabled, then the MAC interface link, speed, and duplex status (determined by the media side) cannot be conveyed to the MAC from the PHY. The user must program the MAC with this information in some other way (for example, by reading PHY registers for link, speed, and duplex status).

## 5.3 Loopback

The host-side SERDES support two loopback paths.

If register 4.F003.12 = 1, then data from the host will loopback to the host as shown in [Figure 20](#).

**Figure 20: Shallow Host Loopback**

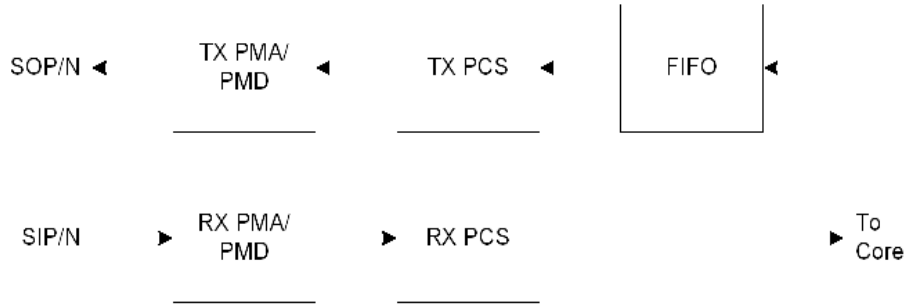

Registers 4.0000.14, 4.1000.14, and 4.2000.14 are physically the same bit. If any of these bits are set to 1, then data from the core will loopback to the core as shown in [Figure 21](#) and [Figure 22](#). If register 4.F003.6, then the ingress path will not be blocked as shown in [Figure 21](#). If register 4.F003.6 = 1, then the ingress path will be blocked as shown in [Figure 22](#).

**Figure 21: Deep Line Loopback, No Ingress Blocking**

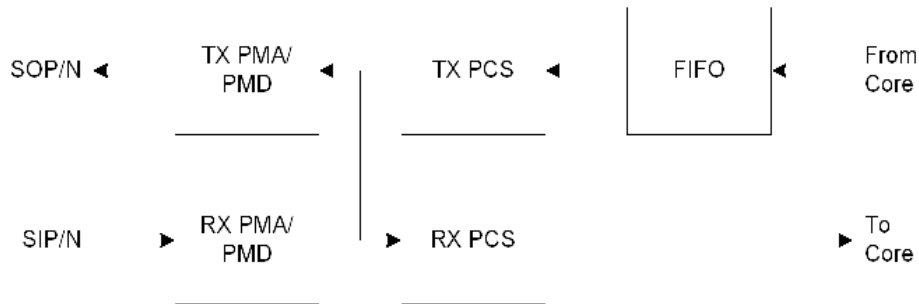

**Figure 22: Deep Line Loopback, Ingress Blocking**

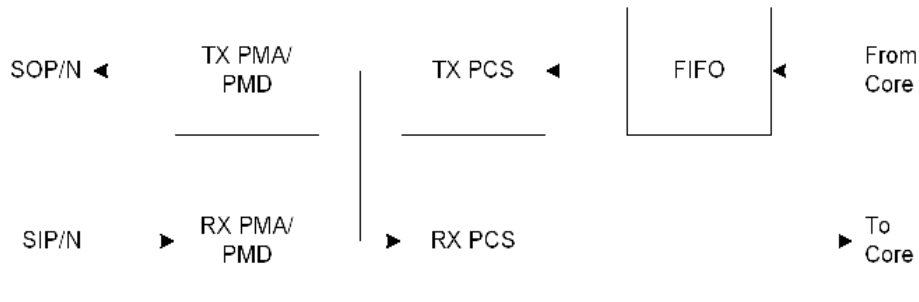



## 5.4 Power Management

The device will automatically power down unused circuits. The host side can be forced into a power down state by setting 4.0000.11, 4.1000.11, or 4.2000.11. These power down registers are physically the same bit even though they reside in different locations.

To soft reset the host side only, set registers 4.0000.15, 4.1000.15, or 4.2000.15. These software reset registers are physically the same bit even though they reside in different locations.

# 6 Electrical Specifications

## 6.1 Absolute Maximum Ratings

**Table 45: Absolute Maximum Rating**

Stresses above those listed in Absolute Maximum Ratings may cause permanent device failure. Functionality at or above these limits is not implied. Exposure to absolute maximum ratings for extended periods may affect device reliability.

| Symbol                            | Parameter  | Min  | Typ | Max               | Units |
|-----------------------------------|--|------|-----|-------------------|-------|
| V <sub>DDAC</sub>                 | Power Supply Voltage on AVDDC with respect to VSS                      | -0.5 | –   | 2.5               | V     |
| V <sub>DDAL</sub>                 | Power Supply Voltage on AVDDL with respect to VSS                      | -0.5 | –   | 2.5               | V     |
| V <sub>DDAH</sub>                 | Power Supply Voltage on AVDDH with respect to VSS                      | -0.5 | –   | 2.5               | V     |
| V <sub>DDAT</sub>                 | Power Supply Voltage on AVDDT with respect to VSS                      | -0.5 | –   | 3.0               | V     |
| V <sub>DDAR</sub>                 | Power Supply Voltage on AVDDR with respect to VSS                      | -0.5 | –   | 2.5               | V     |
| V <sub>DDAS</sub>                 | Power Supply Voltage on AVDDS with respect to VSS                      | -0.5 | –   | 2.5               | V     |
| V <sub>DD</sub>                   | Power Supply Voltage on DVDD with respect to VSS                       | -0.5 | –   | 1.2               | V     |
| V <sub>DDO</sub>                  | Power Supply Voltage on VDDOL, VDDOM, VDDOR, VDDOT with respect to VSS | -0.5 | –   | 3.6               | V     |
| V <sub>HV</sub>                   | Power Supply Voltage on VHV with respect to VSS                        | -0.5 | –   | 1.2               | V     |
| V <sub>PIN</sub>                  | Voltage Applied to Any Digital Input Pin                               | -0.5 | –   | 3.6               | V     |
| T <sub>STORAGE</sub> <sup>a</sup> | Storage Temperature  | -55  | –   | +125 <sup>b</sup> | °C    |

a. The conditions for storing unpowered and unmounted devices are as follows:

- Packed inside a vacuum-sealed moisture barrier bag with desiccant and humidity indicator card (HIC)
- Stored at <40°C and <90% relative humidity (RH)

b. 125°C is only used as bake temperature for not more than 24 hours. Long-term storage (for example, weeks or longer) should be kept at 85°C or lower.



## 6.2 Recommended Operating Conditions

**Table 46: Recommended Operating Conditions**

| Symbol                            | Parameter                                   | Condition                                | Min   | Typ                    | Max              | Units |
|-----------------------------------|---|--|-------|------------------------|------------------|-------|
| V <sub>DDAC</sub> <sup>a, b</sup> | AVDDC Supply                                | For AVDDC                                | 1.455 | 1.5                    | 1.545            | V     |
| V <sub>DDAL</sub> <sup>1, 2</sup> | AVDDL Supply                                | For AVDDL                                | 1.455 | 1.5                    | 1.545            | V     |
| V <sub>DDAH</sub> <sup>1, 2</sup> | AVDDH Supply                                | For AVDDH                                | 1.940 | 2.0                    | 2.060            | V     |
|                                   |   |  | 1.746 | 1.8                    | 1.854            | V     |
| V <sub>DDAT</sub> <sup>1, 2</sup> | AVDDT Supply                                | For AVDDT                                | 2.425 | 2.5                    | 2.575            | V     |
|                                   |   |  | 2.231 | 2.3                    | 2.396            | V     |
| V <sub>DDAR</sub> <sup>1, 2</sup> | AVDDR Supply                                | For AVDDR                                | 1.455 | 1.5                    | 1.545            | V     |
| V <sub>DDAS</sub> <sup>1, 2</sup> | AVDDS Supply                                | For AVDDS                                | 1.455 | 1.5                    | 1.545            | V     |
| V <sub>DD</sub> <sup>1, 2</sup>   | DVDD Supply                                 | For DVDD (C-temp)                        | 0.776 | 0.8                    | 0.824            | V     |
|                                   |   | For DVDD (I-temp)                        | 0.854 | 0.88                   | 0.906            | V     |
| V <sub>DDO</sub> <sup>1, 2</sup>  | VDDOL, VDDOM, VDDOR, VDDOT Supply           | For VDDOM at 1.2V                        | 1.14  | 1.2                    | 1.26             | V     |
|                                   |   | For VDDO* at 1.5V                        | 1.425 | 1.5                    | 1.575            | V     |
|                                   |   | For VDDO* at 1.8V                        | 1.71  | 1.8                    | 1.89             | V     |
|                                   |   | For VDDO* at 2.5V                        | 2.375 | 2.5                    | 2.625            | V     |
|                                   |   | For VDDO* at 3.3V                        | 3.135 | 3.3                    | 3.465            | V     |
| V <sub>HV</sub> <sup>1, 2</sup>   | VHV Supply                                  | Leave floating                           | –     | –                      | –                | V     |
| IREF                              | Internal Bias Reference<br>CIREF, SIREF     | Resistor connected to<br>V <sub>SS</sub> | –     | 4.99K ±1%<br>Tolerance | –                | Ω     |
| T <sub>A</sub>                    | Commercial Ambient<br>Operating Temperature | Commercial Parts <sup>c</sup>            | 0     | –                      | 70               | °C    |
|                                   |   | Industrial Parts <sup>d</sup>            | -40   | –                      | 85               | °C    |
| T <sub>J</sub>                    | Maximum Junction<br>Temperature             |  | –     | –                      | 105 <sup>e</sup> | °C    |

a. Maximum noise allowed on supplies is 25 mV peak-peak.

b. The recommended operating conditions assume that the ripple is included. DC operating conditions with the ripple should never exceed the recommended operating levels. For example, on a system: DVDD supply - 12.5 mV (ripple peak) should be less than 0.776V.

c. Commercial operating temperatures are typically below 70°C, for example, 45°C~55°C. The 70°C maximum is the Marvell specification limit.

d. Industrial part numbers have an / following the commercial part numbers. For details, see [Section 8.1, Part Order Numbering, on page 143](#).

e. Refer to the white paper on T<sub>J</sub> Thermal Calculations for detailed information.

## 6.3 Package Thermal Information

### 6.3.1 Thermal Conditions for 88E2010, 168-pin, HFCBGA Package

Table 47: Thermal Conditions for 88E2010, 168-pin, HFCBGA Package

| Symbol        | Parameter   | Condition   | Min | Typ   | Max | Units |
|---------------|---|---|-----|-------|-----|-------|
| $\theta_{JA}$ | Thermal Resistance <sup>a</sup> - Junction to Ambient for the 168-pin, HFCBGA Package<br><br>$\theta_{JA} = (T_J - T_A)/P$<br>P = Total Power Dissipation   | JEDEC 3 in. x 4.5 in. 4-layer PCB with no air flow          | –   | 19.56 | –   | °C/W  |
|               |   | JEDEC 3 in. x 4.5 in. 4-layer PCB with 1 meter/sec air flow | –   | 16.90 | –   | °C/W  |
|               |   | JEDEC 3 in. x 4.5 in. 4-layer PCB with 2 meter/sec air flow | –   | 15.42 | –   | °C/W  |
|               |   | JEDEC 3 in. x 4.5 in. 4-layer PCB with 3 meter/sec air flow | –   | 14.35 | –   | °C/W  |
| $\psi_{JT}$   | Thermal Characteristic Parameter <sup>a</sup> - Junction to the Top Center of the 168-pin, HFCBGA Package<br><br>$\psi_{JT} = (T_J - T_{top})/P$<br>P = Total Power Dissipation,<br>T <sub>top</sub> : Temperature on the Top Center of the Package | JEDEC 3 in. x 4.5 in. 4-layer PCB with no air flow          | –   | 0.21  | –   | °C/W  |
|               |   | JEDEC 3 in. x 4.5 in. 4-layer PCB with 1 meter/sec air flow | –   | 0.24  | –   | °C/W  |
|               |   | JEDEC 3 in. x 4.5 in. 4-layer PCB with 2 meter/sec air flow | –   | 0.26  | –   | °C/W  |
|               |   | JEDEC 3 in. x 4.5 in. 4-layer PCB with 3 meter/sec air flow | –   | 0.28  | –   | °C/W  |
| $\theta_{JC}$ | Thermal Resistance <sup>a</sup> - Junction to the Case for the 168-pin, HFCBGA Package<br><br>$\theta_{JC} = (T_J - T_C)/P_{top}$<br>P <sub>top</sub> = Power Dissipation from the Top of the Package   | JEDEC with no air flow                                      | –   | 0.66  | –   | °C/W  |
| $\theta_{JB}$ | Thermal Resistance <sup>a</sup> - Junction to the Board for the 168-pin, HFCBGA Package<br><br>$\theta_{JB} = (T_J - T_B)/P_{bottom}$<br>P <sub>bottom</sub> = Power Dissipation from the Bottom of the Package to the PCB Surface                  | JEDEC with no air flow                                      | –   | 8.18  | –   | °C/W  |

a. Refer to the white paper on T<sub>J</sub> Thermal Calculations for detailed information.



## 6.3.2 Thermal Conditions for 88E2040L, 484-pin, HFCBGA Package

Table 48: Thermal Conditions for 88E2040L, 484-pin, HFCBGA Package

| Symbol        | Parameter  | Condition   | Min | Typ  | Max | Units |
|---------------|--|---|-----|------|-----|-------|
| $\theta_{JA}$ | Thermal Resistance <sup>a</sup> - Junction to Ambient for the 484-pin, HFCBGA Package<br><br>$\theta_{JA} = (T_J - T_A)/P$<br>P = Total Power Dissipation  | JEDEC 3 in. x 4.5 in. 4-layer PCB with no air flow          | –   | 9.09 | –   | °C/W  |
|               |  | JEDEC 3 in. x 4.5 in. 4-layer PCB with 1 meter/sec air flow | –   | 7.85 | –   | °C/W  |
|               |  | JEDEC 3 in. x 4.5 in. 4-layer PCB with 2 meter/sec air flow | –   | 7.27 | –   | °C/W  |
|               |  | JEDEC 3 in. x 4.5 in. 4-layer PCB with 3 meter/sec air flow | –   | 6.88 | –   | °C/W  |
| $\psi_{JT}$   | Thermal Characteristic Parameter <sup>a</sup> - Junction to the Top Center of the 484-pin, HFCBGA Package<br><br>$\psi_{JT} = (T_J - T_{top})/P$<br>P = Total Power Dissipation,<br>$T_{top}$ : Temperature on the Top Center of the Package | JEDEC 3 in. x 4.5 in. 4-layer PCB with no air flow          | –   | 0.16 | –   | °C/W  |
|               |  | JEDEC 3 in. x 4.5 in. 4-layer PCB with 1 meter/sec air flow | –   | 0.25 | –   | °C/W  |
|               |  | JEDEC 3 in. x 4.5 in. 4-layer PCB with 2 meter/sec air flow | –   | 0.28 | –   | °C/W  |
|               |  | JEDEC 3 in. x 4.5 in. 4-layer PCB with 3 meter/sec air flow | –   | 0.30 | –   | °C/W  |
| $\theta_{JC}$ | Thermal Resistance <sup>a</sup> - Junction to the Case for the 484-pin, HFCBGA Package<br><br>$\theta_{JC} = (T_J - T_C)/P_{top}$<br>$P_{top}$ = Power Dissipation from the Top of the Package   | JEDEC with no air flow                                      | –   | 0.30 | –   | °C/W  |
| $\theta_{JB}$ | Thermal Resistance <sup>a</sup> - Junction to the Board for the 484-pin, HFCBGA Package<br><br>$\theta_{JB} = (T_J - T_B)/P_{bottom}$<br>$P_{bottom}$ = Power Dissipation from the Bottom of the Package to the PCB Surface                  | JEDEC with no air flow                                      | –   | 2.60 | –   | °C/W  |

a. Refer to the white paper on  $T_J$  Thermal Calculations for information.



## 6.4 Digital I/O Electrical Specifications

### 6.4.1 DC Operating Conditions

**Table 49: DC Operating Conditions**

(Over full range of values listed in the Recommended Operating Conditions unless otherwise specified)

| Symbol           | Parameter                 | Pins                                     | Condition   | Min         | Typ | Max         | Units |
|------------------|---------------------------|--|-------------|-------------|-----|-------------|-------|
| VIH              | Input High Voltage        | All digital inputs                       | VDDO = 3.3V | 2.0         | –   | VDDO + 0.3V | V     |
|                  |                           |  | VDDO = 2.5V | 1.75        | –   | VDDO + 0.3V | V     |
|                  |                           |  | VDDO = 1.8V | 1.26        | –   | VDDO + 0.3V | V     |
|                  |                           |  | VDDO = 1.5V | 1.05        | –   | VDDO + 0.3V | V     |
|                  |                           |  | VDDO = 1.2V | 0.84        | –   | VDDO + 0.3V | V     |
| VIL              | Input Low Voltage         | All digital inputs                       | VDDO = 3.3V | -0.3        | –   | 0.8         | V     |
|                  |                           |  | VDDO = 2.5V | -0.3        | –   | 0.75        | V     |
|                  |                           |  | VDDO = 1.8V | -0.3        | –   | 0.54        | V     |
|                  |                           |  | VDDO = 1.5V | -0.3        | –   | 0.45        | V     |
|                  |                           |  | VDDO = 1.2V | -0.3        | –   | 0.36        | V     |
| VOH              | High-level Output Voltage | All digital outputs                      | IOH = -4 mA | VDDO - 0.4V | –   | –           | V     |
| VOL              | Low-level Output Voltage  | All digital outputs                      | IOL = 4 mA  | –           | –   | 0.4         | V     |
| I <sub>ILK</sub> | Input Leakage Current     | With internal pull-up/pull-down resistor | –           | 10          | –   | 70          | μA    |
|                  |                           | All others without resistor              | –           | –           | –   | 10          | μA    |
| I <sub>LED</sub> | Max Current per LED Pin   | All LED pins                             | –           | –           | –   | 8           | mA    |
| CIN              | Input Capacitance         | All pins                                 | –           | –           | –   | 5           | pF    |



### 6.4.2 Reset Timing

Table 50: Reset Timing

(Over Full range of values listed in the Recommended Operating Conditions unless otherwise specified)

| Symbol                 | Parameter  | Condition | Min | Typ | Max | Units |
|------------------------|--|-----------|-----|-----|-----|-------|
| T <sub>PU_RESET</sub>  | Valid Power to RESET De-asserted                         | –         | 10  | –   | –   | ms    |
| T <sub>SU_REFCLK</sub> | Number of Valid REFCLK Cycles Prior to RESET De-asserted | –         | 10  | –   | –   | clks  |
| T <sub>RESET</sub>     | Minimum Reset Pulse Width During Normal Operation        | –         | 10  | –   | –   | ms    |

Figure 23: Reset Timing

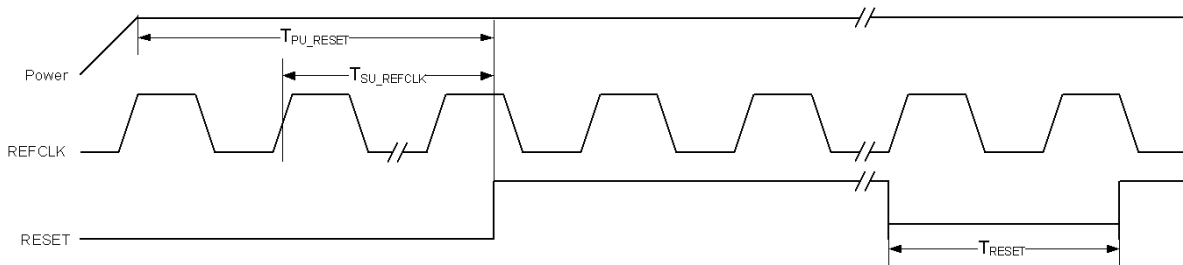

### 6.4.3 LED to CONFIG Timing

Table 51: LED to CONFIG Timing

| Symbol                  | Parameter           | Condition | Min | Typ | Max | Units |
|-------------------------|---------------------|-----------|-----|-----|-----|-------|
| T <sub>DLY_CONFIG</sub> | LED to CONFIG Delay | –         | 0   | –   | 25  | ns    |

Figure 24: LED to CONFIG Timing

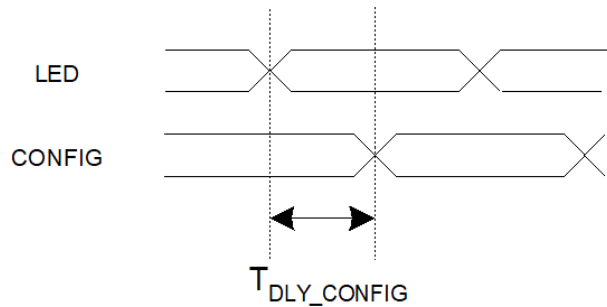

## 6.4.4 MDC/MDIO Management Interface Timing

**Table 52: MDC/MDIO Management Interface Timing**

(Over full range of values listed in the Recommended Operating Conditions unless otherwise specified)

| Symbol          | Parameter                       | Min | Typ | Max | Units |
|-----------------|---------------------------------|-----|-----|-----|-------|
| $T_{DLY\_MDIO}$ | MDC-to-MDIO (Output) Delay Time | 2   | –   | 16  | ns    |
| $T_{SU\_MDIO}$  | MDIO- (Input) to-MDC Setup Time | 3   | –   | –   | ns    |
| $T_{HD\_MDIO}$  | MDIO- (Input) to-MDC Hold Time  | 3   | –   | –   | ns    |
| $T_{P\_MDC}$    | MDC Period                      | 35  | –   | –   | ns    |
| $T_{H\_MDC}$    | MDC High                        | 17  | –   | –   | ns    |
| $T_{L\_MDC}$    | MDC Low                         | 17  | –   | –   | ns    |
| $V_{HYST}$      | VDDO Input Hysteresis           | –   | 360 | –   | mV    |
| $T_{P\_MDC}$    | MDC Period                      | 35  | –   | –   | ns    |
| $T_{read\_dly}$ | Read Delay                      | 160 | –   | –   | ns    |

**Figure 25: MDC/MDIO Management Interface Timing**

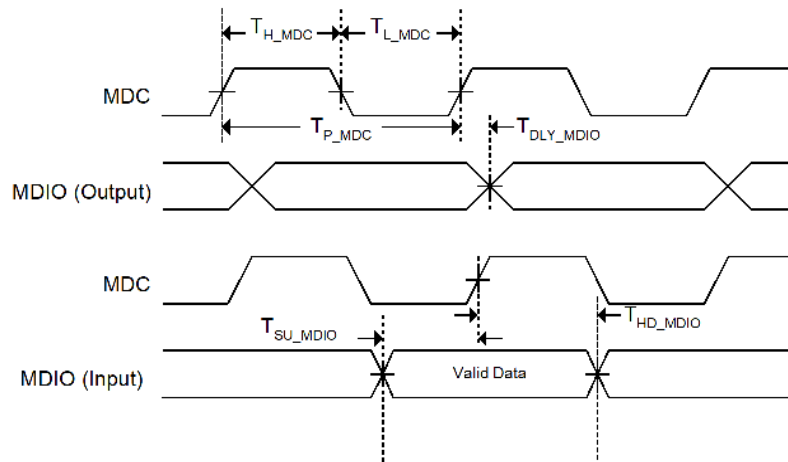
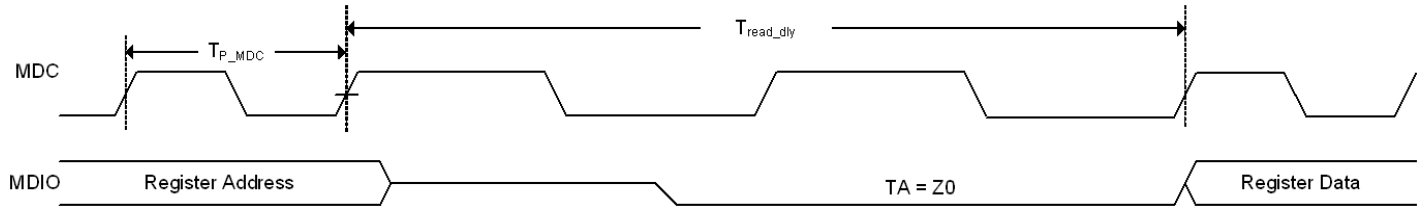

**Figure 26: MDC/MDIO Input Hysteresis**





Figure 27: MDC Read Turnaround Delay



## 6.4.5 JTAG Timing

**Table 53: JTAG Timing**

(Over full range of values listed in the Recommended Operating Conditions unless otherwise specified)

| Symbol         | Parameter                  | Condition | Min | Typ | Max | Units |
|----------------|----------------------------|-----------|-----|-----|-----|-------|
| $T_{P\_TCK}$   | TCK Period                 | –         | 60  | –   | –   | ns    |
| $T_{H\_TCK}$   | TCK High                   | –         | 12  | –   | –   | ns    |
| $T_{L\_TCK}$   | TCK Low                    | –         | 12  | –   | –   | ns    |
| $T_{SU\_TDI}$  | TDI, TMS-to-TCK Setup Time | –         | 10  | –   | –   | ns    |
| $T_{HD\_TDI}$  | TDI, TMS-to-TCK Hold Time  | –         | 10  | –   | –   | ns    |
| $T_{DLY\_TDO}$ | TCK-to-TDO Delay           | –         | 0   | –   | 15  | ns    |

**Figure 28: JTAG Timing**

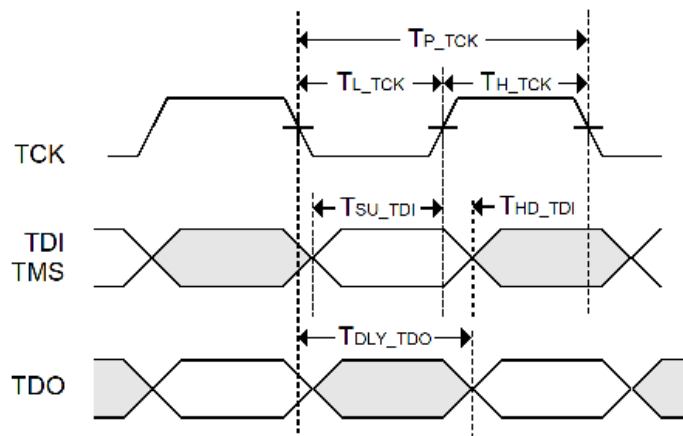



### 6.4.6 SPI Interface Timing

**Table 54: SPI Interface Timing**

(Over full range of values listed in the Recommended Operating Conditions unless otherwise specified)

| Symbol                                  | Parameter                    | Condition | Min | Typ   | Max | Units |
|---|------------------------------|-----------|-----|-------|-----|-------|
| T <sub>SCK_PER</sub>                    | SCK Period                   | –         | –   | 204.8 | –   | ns    |
|   | SCK Duty Cycle               | –         | 48  | 50    | 52  | %     |
| T <sub>O_min to T<sub>O_max</sub></sub> | MOSI Valid from SCK Low      | –         | 0   | –     | 20  | ns    |
| T <sub>DH</sub>                         | MISO Hold Time from SCK High | –         | 0   | –     | –   | ns    |
| T <sub>DS</sub>                         | MISO Setup Time to SCK High  | –         | 50  | –     | –   | ns    |

**Figure 29: SPI Interface Timing**

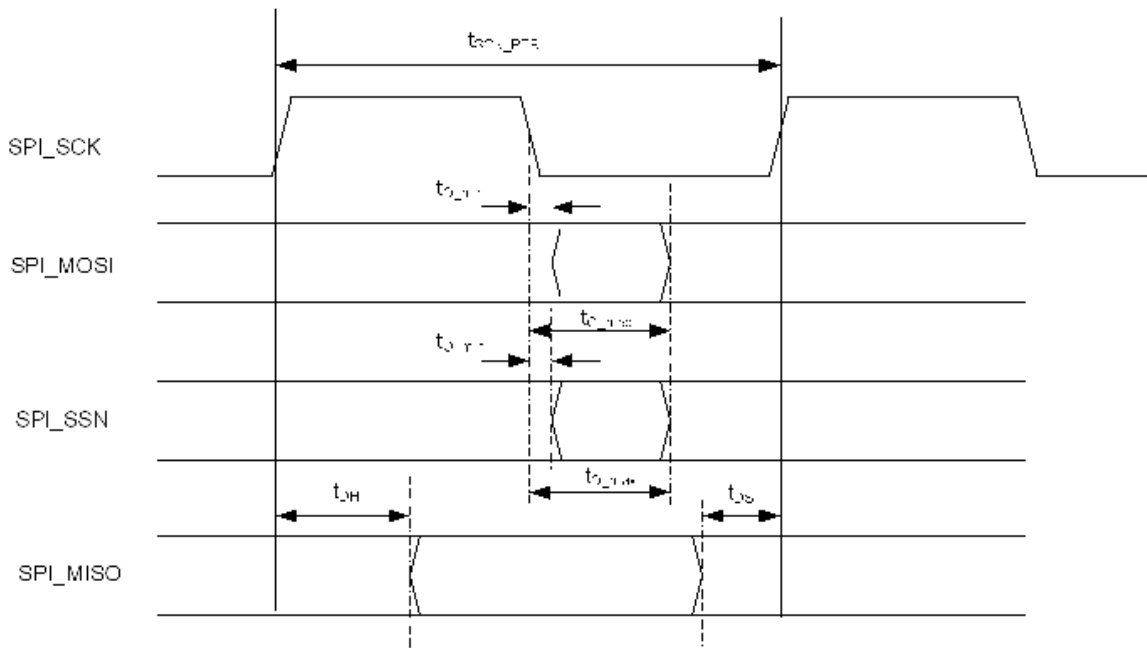

## 6.5 Analog Electrical Specifications

### 6.5.1 SGMII Electrical Summary

**Table 55: SGMII Electrical Summary**

| Test Parameters                         | Specification     |      |      | Units    |
|---|-------------------|------|------|----------|
|   | Transmitter Tests |      |      |          |
|   | Min               | Mean | Max  |          |
| Output Voltage High                     | –                 | –    | 1525 | mV       |
| Output Voltage Low                      | 875               | –    | –    | mV       |
| Output Ringing                          | –                 | –    | 10   | %        |
| Output Differential Voltage             | 150               | –    | 400  | mV       |
| Output Offset Voltage                   | 1.075             | –    | –    | V        |
| Single-ended Output Impedance           | 40                | –    | –    | $\Omega$ |
| Output Current On Short to Gnd          | –                 | –    | 40   | mA       |
| Output Current When P and N are Shorted | –                 | –    | 12   | mA       |
| Power Off Leakage Current               | –                 | –    | 10   | mA       |
| Skew Between P and N                    | –                 | –    | 20   | ps       |
| Total Output Jitter                     | –                 | –    | 300  | ps       |
| Receiver Tests                          |                   |      |      |          |
| Sensitivity                             | –                 | –    | 100  | mVpp     |
| Single-ended Termination                | –                 | 50   | –    | $\Omega$ |
| Jitter Tolerance                        | 500               | –    | –    | ps       |



## 6.5.2 2500BASE-X Electrical Summary

Table 56: 2500BASE-X Electrical Summary

| Test Parameters                               | Specification     |       |          | Units |
|---|-------------------|-------|----------|-------|
|   | Transmitter Tests |       |          |       |
|   | Min               | Mean  | Max      |       |
| Signaling Rate                                | -100 ppm          | 3.125 | +100 ppm | GBaud |
| Nominal Unit Interval                         | –                 | 320   | –        | ps    |
| Differential Output                           | 800               | 1000  | 1200     | mVpp  |
| Deterministic Jitter                          | –                 | –     | 0.17     | UI    |
| Random Jitter                                 | –                 | –     | 0.27     | UI    |
| Total Output Jitter                           | –                 | –     | 0.35     | UI    |
| Receiver Tests                                |                   |       |          |       |
| Signaling Rate                                | -100 ppm          | 3.125 | +100 ppm | GBaud |
| Nominal Unit Interval                         | –                 | 320   | –        | ps    |
| Differential Input Peak-to-Peak Amplitude     | –                 | –     | 1600     | mVpp  |
| Applied Sinusoidal Jitter (Min. Peak-to-Peak) | 0.17              | –     | –        | UI    |
| Applied Random Jitter (Min. Peak-to-Peak)     | 0.18              | –     | –        | UI    |



### 6.5.3 5GBASE-R Electrical Summary

**Table 57: 5GBASE-R Electrical Summary**

| Test Parameters                               | Specification     |       |          | Units |
|---|-------------------|-------|----------|-------|
|   | Transmitter Tests |       |          |       |
|   | Min               | Mean  | Max      |       |
| Signaling Rate                                | -100 ppm          | 3.125 | +100 ppm | GBaud |
| Nominal Unit Interval                         | –                 | 193.9 | –        | ps    |
| Differential Output                           | –                 | –     | 1200     | mVpp  |
| Deterministic Jitter                          | –                 | –     | 0.12     | UI    |
| Random Jitter                                 | –                 | –     | 0.15     | UI    |
| Total Output Jitter                           | –                 | –     | 0.27     | UI    |
| Receiver Tests                                |                   |       |          |       |
| Signaling Rate                                | -100 ppm          | 3.125 | +100 ppm | GBaud |
| Nominal Unit Interval                         | –                 | 193.9 | –        | ps    |
| Applied Random Jitter (Min. Peak-to-Peak)     | 0.15              | –     | –        | UI    |
|   | 5 UI @ 0.02 MHz   | –     | –        | N/A   |
|   | 0.15 UI @ 4 MHz   | –     | –        |       |
| Applied Sinusoidal Jitter (Min. Peak-to-Peak) | 0.15 UI @ 20 MHz  | –     | –        |       |



## 6.5.4 10BASE-Te, 100BASE-TX, and 1000BASE-T Electrical Parameters

IEEE tests are typically based on template and cannot simply be specified by a number. For an exact description of the template and the test conditions, refer to the IEEE specifications.

- 10BASE-Te IEEE 802.3 Clause 14
- 100BASE-TX ANSI X3.263-1995
- 1000BASE-T IEEE Clause 40

**Table 58: IEEE DC Transceiver Parameters**

(Over full range of values listed in the Recommended Operating Conditions unless otherwise specified)

| Symbol             | Parameter                                 | Pins        | Condition               | Min              | Typ              | Max   | Units        |
|--------------------|---|-------------|-------------------------|------------------|------------------|-------|--------------|
| V <sub>ODIFF</sub> | Absolute Peak Differential Output Voltage | MDIP/N[1:0] | 10BASE-Te no cable      | 1.54             | –                | 1.96  | V            |
|                    |   | MDIP/N[1:0] | 10BASE-Te cable model   | 585 <sup>a</sup> | –                | –     | mV           |
|                    |   | MDIP/N[1:0] | 100BASE-TX mode         | 0.950            | –                | 1.050 | V            |
|                    |   | MDIP/N[3:0] | 1000BASE-T <sup>b</sup> | 0.67             | –                | 0.82  | V            |
|                    | Overshoot <sup>2</sup>                    | MDIP/N[1:0] | 100BASE-TX mode         | 0                | –                | 5     | %            |
|                    | Amplitude Symmetry (Positive/Negative)    | MDIP/N[1:0] | 100BASE-TX mode         | 98               | –                | 102   | V+/V-        |
| V <sub>IDIFF</sub> | Peak Differential Input Voltage           | MDIP/N[1:0] | 10BASE-Te mode          | 585 <sup>c</sup> | –                | –     | mV           |
|                    | Signal Detect Assertion                   | MDIP/N[1:0] | 100BASE-TX mode         | 1000             | 460 <sup>d</sup> | –     | mV peak-peak |
|                    | Signal Detect De-assertion                | MDIP/N[1:0] | 100BASE-TX mode         | 200              | 360 <sup>e</sup> | –     | mV peak-peak |

- a. IEEE 802.3 Clause 14, Figure 14.9 shows the template for the far-end wave form. This template allows as little as 495 mV peak differential voltage at the far end receiver.
- b. IEEE 802.3ab Figure 40 -19 points A&B.
- c. The input test is actually a template test; IEEE 802.3 Clause 14, Figure 14.17 shows the template for the receive waveform.
- d. The ANSI TP-PMD specification requires that any received signal with peak-to-peak differential amplitude greater than 1000 mV should turn on signal detect (internal signal in 100BASE-TX mode). The device accepts signals typically with 460 mV peak-to-peak differential amplitude.
- e. The ANSI-PMD specification requires that any received signal with peak-to-peak differential amplitude less than 200 mV should de-assert signal detect (internal signal in 100BASE-TX mode). The device will reject signals typically with peak-to-peak differential amplitude less than 360 mV.

## 6.5.5 IEEE DC Transceiver Parameters

IEEE tests are typically based on template and cannot simply be specified by a number. For an exact description of the template and the test conditions, refer to the IEEE specifications.

-10BASE-T IEEE 802.3 Clause 14

-100BASE-TX ANSI X3.263-1995

**Table 59: IEEE DC Transceiver Parameters**

(Over full range of values listed in the Recommended Operating Conditions unless otherwise specified)

| Symbol             | Parameter                                 | Pins        | Condition               | Min              | Typ              | Max   | Units        |
|--------------------|---|-------------|-------------------------|------------------|------------------|-------|--------------|
| V <sub>ODIFF</sub> | Absolute Peak Differential Output Voltage | MDIP/N[1:0] | 10BASE-T no cable       | 0.950            | 1.0              | 1.050 | V            |
|                    |   | MDIP/N[1:0] | 10BASE-T cable model    | 585 <sup>a</sup> | –                | –     | mV           |
|                    |   | MDIP/N[1:0] | 100BASE-TX mode         | 0.950            | 1.0              | 1.050 | V            |
|                    |   | MDIP/N[3:0] | 1000BASE-T <sup>b</sup> | 0.67             | 0.75             | 0.82  | V            |
|                    | Overshoot <sup>2</sup>                    | MDIP/N[1:0] | 100BASE-TX mode         | 0                | –                | 5%    | V            |
|                    | Amplitude Symmetry (Positive/Negative)    | MDIP/N[1:0] | 100BASE-TX mode         | 0.98x            | –                | 1.02x | V+/-         |
| V <sub>IDIFF</sub> | Peak Differential Input Voltage           | MDIP/N[1:0] | 10BASE-T mode           | 585 <sup>c</sup> | –                | –     | mV           |
|                    | Signal Detect Assertion                   | MDIP/N[1:0] | 100BASE-TX mode         | 100              | 460 <sup>d</sup> | –     | mV peak-peak |
|                    | Signal Detect De-assertion                | MDIP/N[1:0] | 100BASE-TX mode         | 200              | 360 <sup>e</sup> | –     | mV peak-peak |

a. IEEE 802.3 Clause 14, Figure 14.9 shows the template for the far-end waveform. This template allows as little as 495 mV peak differential voltage at the far end receiver.

b. IEEE 802.3ab Figure 40 -19 points A&B.

c. The input test is actually a template test; IEEE 802.3 Clause 14, Figure 14.17 shows the template for the receive wave form.

d. The ANSI TP-PMD specification requires that any received signal with peak-to-peak differential amplitude greater than 1000 mV should turn on signal detect (internal signal in 100BASE-TX mode).

e. The ANSI-PMD specification requires that any received signal with peak-to-peak differential amplitude less than 200 mV should de-assert signal detect (internal signal in 100BASE-TX mode). The device will reject signals typically with peak-to-peak differential amplitude less than 360 mV.



## 6.6 Reference Clock

### 6.6.1 CLKP/N Timing — 156.25 MHz

**Table 60: CLKP/N Timing — 156.25 MHz**

| Symbol | Parameter         | Condition                      | Min     | Typ    | Max             | Units        |
|--------|-------------------|--------------------------------|---------|--------|-----------------|--------------|
| Fclk   | Frequency         | –                              | -50 ppm | 156.25 | +50 ppm         | MHz          |
| tr, tf | Rise, Fall Time   | 20 to 80% of swing             | 0.3     | 0.5    | 0.8             | ns           |
| A      | Amplitude         | Differential pk                | 0.4     | 0.75   | 0.9             | V            |
| Tduty  | Duty Cycle        | –                              | 0.45    | 0.5    | 0.55            | –            |
| Tj     | Jitter            | Integrated from<br>1 to 30 MHz | –       | –      | 0.5             | ps,<br>(RMS) |
| Zin    | Input Impedance   | Differential                   | 90      | 100    | 110             | $\Omega$     |
| Vicm   | Input CM          | CLK can be DC<br>coupled.      | 0.1     | –      | AVDDC -<br>0.1V | V            |
| SDD11  | Input Return Loss | Differential, 100 $\Omega$     | –       | –      | -12             | db           |

**Note**

When the transmitter or the receiver is in LPI transmit mode or switching to and from the LPI mode, a short-term rate of frequency variation will be less than 0.1 ppm/second.

## 6.6.2 CLKP/N Timing — 50 MHz

**Table 61: CLKP/N Timing — 50 MHz**

| Symbol | Parameter         | Condition                   | Min     | Typ  | Max          | Units     |
|--------|-------------------|-----------------------------|---------|------|--------------|-----------|
| Fclk   | Frequency         | –                           | -50 ppm | 50   | +50 ppm      | MHz       |
| tr, tf | Rise, Fall Time   | 20 to 80% of swing          | 0.3     | 0.5  | 0.8          | ns        |
| A      | Amplitude         | Differential pk-pk          | 0.4     | 0.75 | 0.9          | V         |
| Tduty  | Duty Cycle        | –                           | 0.45    | 0.5  | 0.55         | –         |
| Tj     | Jitter            | Integrated from 1 to 30 MHz | –       | –    | 0.5          | ps, (RMS) |
| Zin    | Input Impedance   | Differential                | 90      | 100  | 110          | $\Omega$  |
| Vicm   | Input CM          | CLK can be DC coupled.      | 0.1     | –    | AVDDC - 0.1V | V         |
| SDD11  | Input Return Loss | Differential, 100 $\Omega$  | –       | –    | -12          | db        |



### 6.6.3 XTAL Timing<sup>a</sup> Data

**Table 62: XTAL Timing**

(Over full range of values listed in the Recommended Operating Conditions unless otherwise specified)

| Symbol              | Parameter                      | Condition | Min           | Typ | Max           | Units |
|---------------------|--------------------------------|-----------|---------------|-----|---------------|-------|
| T <sub>P_XTAL</sub> | XTAL Period                    | –         | 20<br>-50 ppm | 20  | 20<br>+50 ppm | ns    |
| T <sub>H_XTAL</sub> | XTAL High Time                 | –         | 6.5           | 10  | 13.5          | ns    |
| T <sub>L_XTAL</sub> | XTAL Low Time                  | –         | 6.5           | 10  | 13.5          | ns    |
| T <sub>R_XTAL</sub> | XTAL Rise                      | 10 to 90% | –             | 2.0 | –             | ns    |
| T <sub>F_XTAL</sub> | XTAL Fall                      | 90 to 10% | –             | 2.0 | –             | ns    |
| T <sub>J_XTAL</sub> | XTAL Total Jitter <sup>b</sup> | –         | –             | –   | 200           | ps    |

- a. If the crystal option is used, then ensure that the frequency is 50 MHz ±50 ppm. Capacitors must be chosen carefully - see the application note supplied by the crystal vendor.
- b. PLL-generated clocks are not recommended as input to XTAL since they can have excessive jitter. Zero delay buffers are also not recommended for the same reason.



**Note**

50 MHz crystal operation is only supported for commercial-grade devices.

**Figure 30: XTAL Timing**

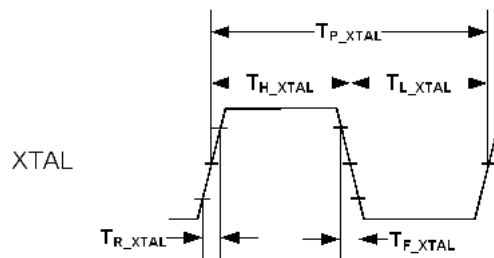

## 6.7 Latency

The total latency in the egress direction is  $T_{EGRESS} + T_{EGRESS\_HL} + T_{CORE}$ . The total latency in the ingress direction is  $T_{INGRESS} + T_{CORE}$ . If the high latency mode is not used, then the  $T_{CORE}$  and  $T_{EGRESS\_HL}$  are 0, respectively.

**Table 63: Egress Path Latency<sup>a b c d</sup> Data**

| Symbol       | Condition (per Port, Line to Host)  | Min    | Typ    | Max    | Unit |
|--------------|-------------------------------------|--------|--------|--------|------|
| $T_{EGRESS}$ | Reserved to 5GBASE-T                | 1,698  | 1,713  | 1,740  | ns   |
|              | Reserved to 2.5GBASE-T              | 2,727  | 2,753  | 2,802  | ns   |
|              | Reserved to 1000BASE-T              | 358    | 385    | 423    | ns   |
|              | Reserved to 1000BASE-X/SGMII-1000   | 318    | 367    | 428    | ns   |
|              | Reserved to 100BASE-T               | 2,381  | 2,552  | 2,814  | ns   |
|              | Reserved to 10BASE-T                | 19,542 | 21,157 | 23,593 | ns   |
|              | 5GBASE-R to 5GBASE-T                | 1,716  | 1,731  | 1,752  | ns   |
|              | 2500BASE-X to 2.5GBASE-T            | 2,746  | 2,765  | 2,804  | ns   |
|              | 1000BASE-X/SGMII-1000 to 1000BASE-T | 271    | 302    | 332    | ns   |
|              | 1000BASE-X/SGMII-1000 to 1000BASE-X | 231    | 284    | 337    | ns   |
|              | SGMII to 100BASE-TX                 | 1,143  | 1,174  | 1,298  | ns   |
|              | SGMII to 10BASE-T                   | 6,192  | 6,290  | 6,428  | ns   |

- a. Latency numbers are based on default ppm FIFO depth = 01 in both egress and ingress direction.
- b. The packet size used for ingress side RM FIFO simulation is 1512+4 (CRC) bytes per packet.
- c. Low latency enabled
- d.  $T_{EGRESS\_HL} @5G = 625$  ns,  $T_{EGRESS\_HL} @2.5G = 1,875$  ns, and others = 0 ns

**Table 64: Ingress Path Latency<sup>a b c d</sup> Data**

| Symbol               | Condition (per Port, Line to Host)  | Min    | Typ    | Max    | Unit |
|----------------------|-------------------------------------|--------|--------|--------|------|
| T <sub>INGRESS</sub> | 5GBASE-T to Reserved                | 1,394  | 1,415  | 1,449  | ns   |
|                      | 2.5GBASE-T to Reserved              | 2,625  | 2,664  | 2,726  | ns   |
|                      | 1000BASE-T to Reserved              | 521    | 556    | 602    | ns   |
|                      | 1000BASE-X/SGMII-1000 to Reserved   | 412    | 461    | 522    | ns   |
|                      | 100BASE-TX to Reserved              | 2,990  | 3,241  | 3,583  | ns   |
|                      | 5GBASE-R/2500BASE-X to Reserved     | 125    | 135    | 150    | ns   |
|                      | 5GBASE-T to 5GBASE-R                | 1,367  | 1,384  | 1,405  | ns   |
|                      | 2500BASE-T to 2.5GBASE-X            | 2,541  | 2,587  | 2,626  | ns   |
|                      | 1000BASE-T to 1000BASE-X/SGMII-1000 | 340    | 379    | 417    | ns   |
|                      | 1000BASE-X to 1000BASE-X/SGMII-1000 | 231    | 284    | 337    | ns   |
|                      | 100BASE-TX to SGMII                 | 1,242  | 1,352  | 1,391  | ns   |
|                      | 10BASE-T to SGMII                   | 11,358 | 12,193 | 12,245 | ns   |

- a. Latency numbers are based on default ppm FIFO depth = 01 in both egress and ingress direction.  
b. The packet size used for ingress side RM FIFO simulation is 1512+4 (CRC) bytes per packet.  
c. Low latency enabled.  
d. T<sub>EGRESS\_HL @5G</sub> = 625 ns, T<sub>EGRESS\_HL @2.5G</sub> = 1,875 ns, and others = 0 ns



# 7 Mechanical Drawing

## 7.1 168-pin 10 mm x 12 mm HFCBGA Package Mechanical Drawings

Figure 31: 168-pin 10 mm x 12 mm HFCBGA Top and Side View

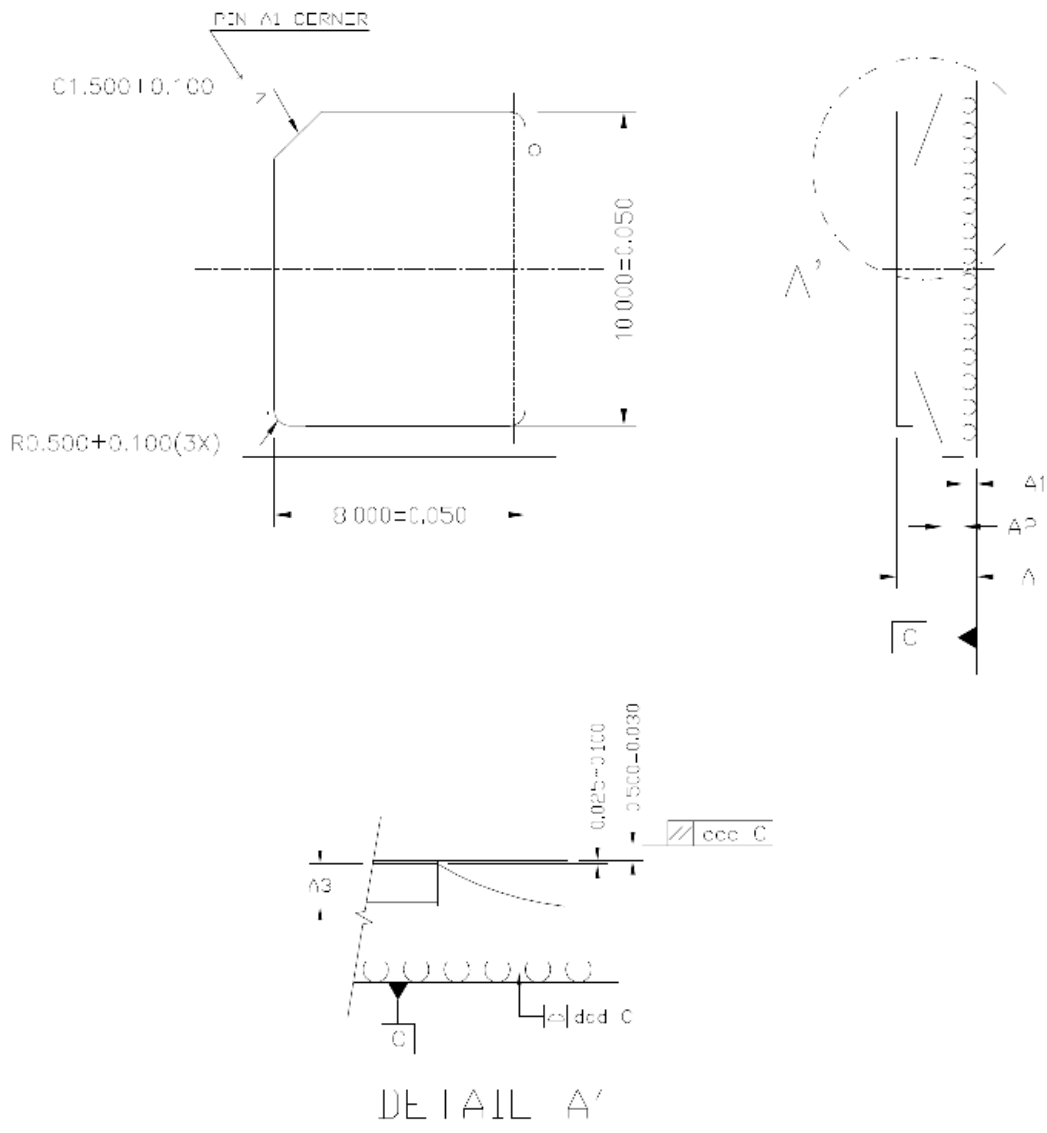
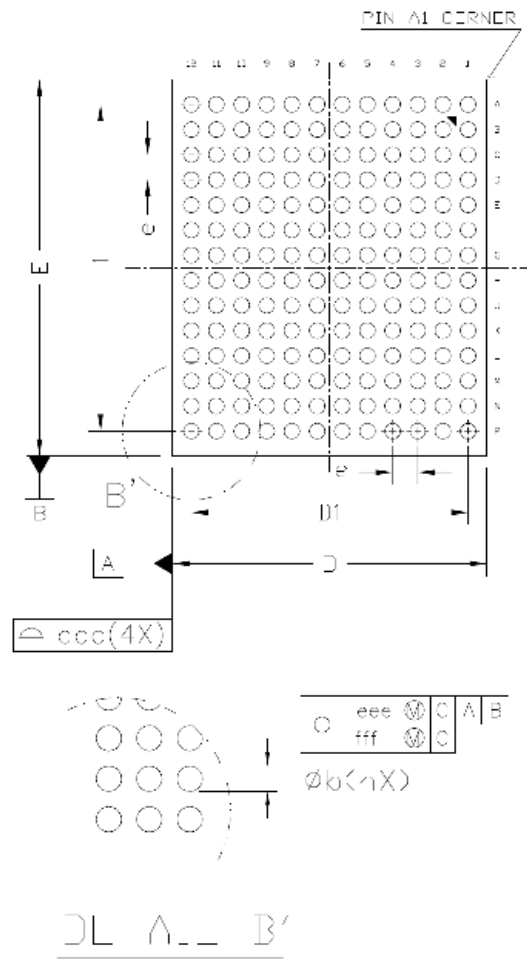



Figure 32: 168-pin 10 mm x 12 mm HFCBGA Bottom View



**Table 65: 168-pin 10 mm x 12 mm HFCBGA Package Dimensions**

|  | SYMBOL | COMMON DIMENSIONS |       |       |
|--|--------|-------------------|-------|-------|
|  |        | MIN.              | NOM.  | MAX.  |
| TOTAL THICKNESS                                  | A      | 2.407             | 2.527 | 2.647 |
| STAND OFF  | A1     | 0.360             | --    | 0.460 |
| SUBSTRATE THICKNESS                              | A2     | 0.670 REF         |       |       |
| THICKNESS FROM SUBSTRATE SURFACE TO DIE BACKSIDE | A3     | 0.887 REF         |       |       |
| BODY SIZE  | D      | 10.000 BSC        |       |       |
|  | E      | 12.000 BSC        |       |       |
| BALL DIAMETER                                    |        | 0.500             |       |       |
| BALL WIDTH                                       | b      | 0.440             | --    | 0.640 |
| BALL PITCH                                       | e      | 0.800 BSC         |       |       |
| BALL COUNT                                       | n      | 168               |       |       |
| EDGE BALL CENTER TO CENTER                       | D1     | 8.800 BSC         |       |       |
|  | E1     | 10.400 BSC        |       |       |
| EXPOSE DIE SIZE                                  | D2     | --                |       |       |
|  | E2     | --                |       |       |
| PACKAGE EDGE TOLERANCE                           | aaa    | 0.100             |       |       |
| SUBSTRATE PARALLELISM                            | bbb    | --                |       |       |
| TOP PARALLELISM                                  | ccc    | 0.200             |       |       |
| COPLANARITY                                      | ddd    | 0.150             |       |       |
| BALL OFFSET (PACKAGE)                            | eee    | 0.150             |       |       |
| BALL OFFSET (BALL)                               | fff    | 0.80              |       |       |



## 7.2 484-pin 23 mm x 23 mm HFCBGA Package Mechanical Drawings

Figure 33: 484-pin 23 mm x 23 mm HFCBGA Top and Side View

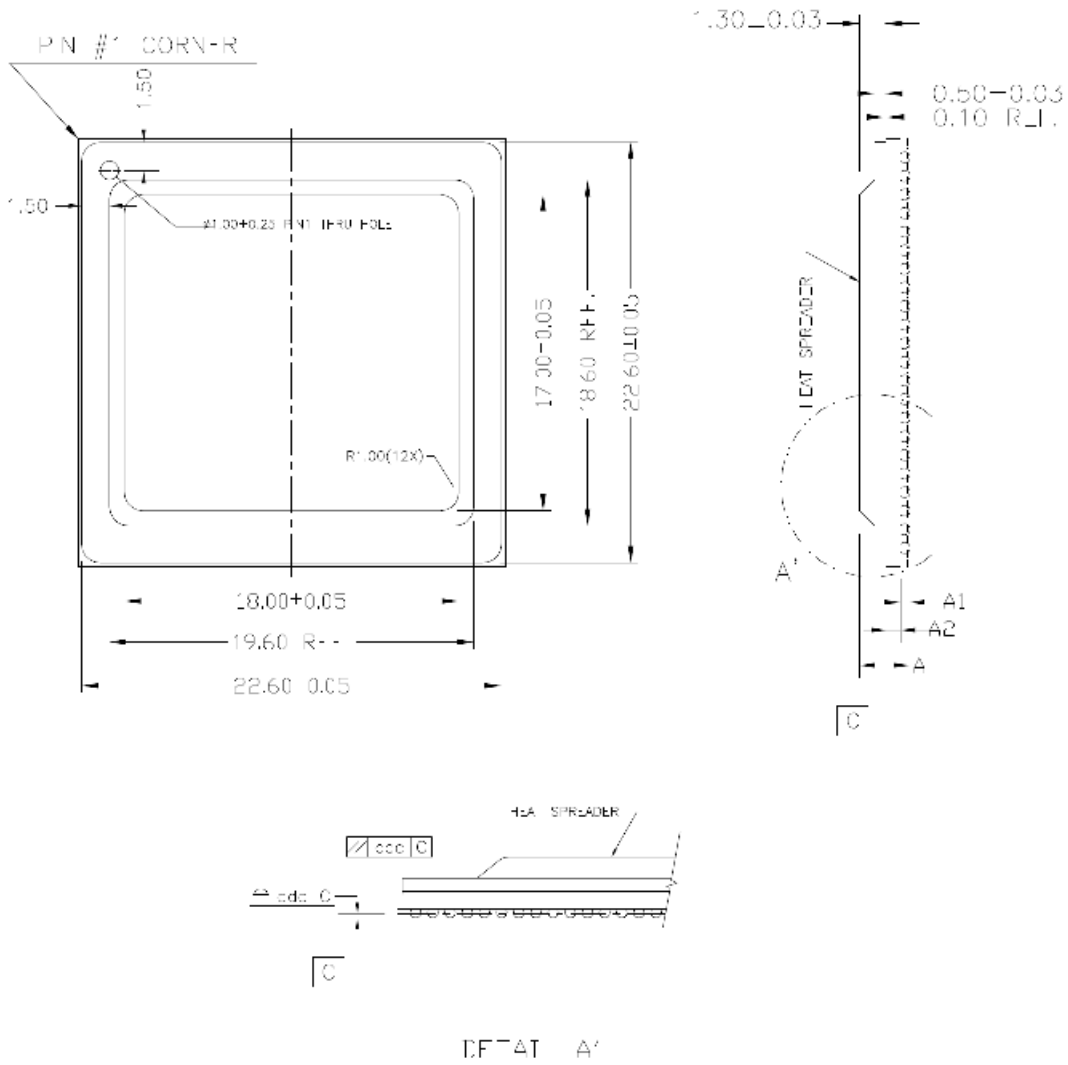

Figure 34: 484-pin 23 mm x 23 mm HFCBGA Bottom View

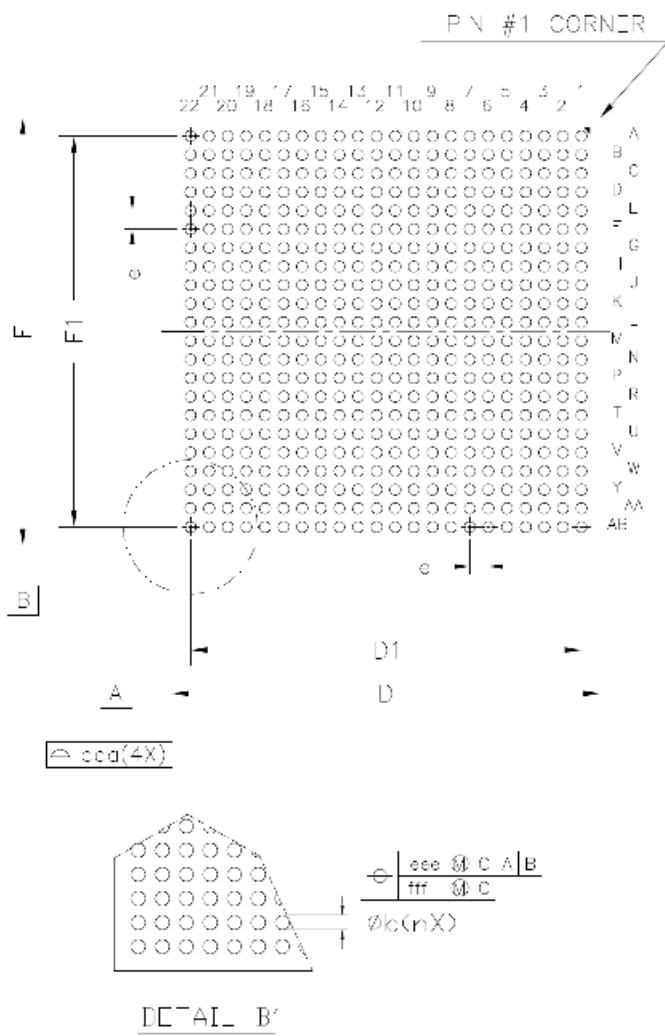



Table 66: 484-pin 23 mm x 23 mm HFCBGA Package Dimensions

|  | SYMBOL | COMMON DIMENSIONS |       |       |
|--|--------|-------------------|-------|-------|
|  |        | MIN.              | NOM.  | MAX.  |
| TOTAL THICKNESS                                  | A      | 2.580             | 2.700 | 2.820 |
| STAND OFF  | A1     | 0.400             | --    | 0.600 |
| SUBSTRATE THICKNESS                              | A2     | 0.800 REF         |       |       |
| THICKNESS FROM SUBSTRATE SURFACE TO DIE BACKSIDE | A3     | -- REF            |       |       |
| BODY SIZE  | D      | 23.000 BSC        |       |       |
|  | E      | 23.000 BSC        |       |       |
| BALL DIAMETER                                    |        | 0.600             |       |       |
| BALL WIDTH                                       | b      | 0.500             | --    | 0.700 |
| BALL PITCH                                       | e      | 1.000 BSC         |       |       |
| BALL COUNT                                       | n      | 484               |       |       |
| EDGE BALL CENTER TO CENTER                       | D1     | 21.000 BSC        |       |       |
|  | E1     | 21.000 BSC        |       |       |
| EXPOSE DIE SIZE                                  | D2     | --                |       |       |
|  | E2     | --                |       |       |
| PACKAGE EDGE TOLERANCE                           | aaa    | 0.100             |       |       |
| SUBSTRATE PARALLELISM                            | bbb    | --                |       |       |
| TOP PARALLELISM                                  | ccc    | 0.200             |       |       |
| COPLANARITY                                      | ddd    | 0.150             |       |       |
| BALL OFFSET (PACKAGE)                            | eee    | 0.150             |       |       |
| BALL OFFSET (BALL)                               | fff    | 0.100             |       |       |

# 8

## Part Order Numbering/Package Marking

This section includes information on the following topics:

- Section 8.1, Part Order Numbering
- Section 8.2, Package Marking

### 8.1 Part Order Numbering

Figure 35 shows the ordering part numbering scheme for the 88E2010/88E2040L devices. Contact Marvell FAEs or sales representatives for complete ordering information.

Figure 35: Sample Part Number

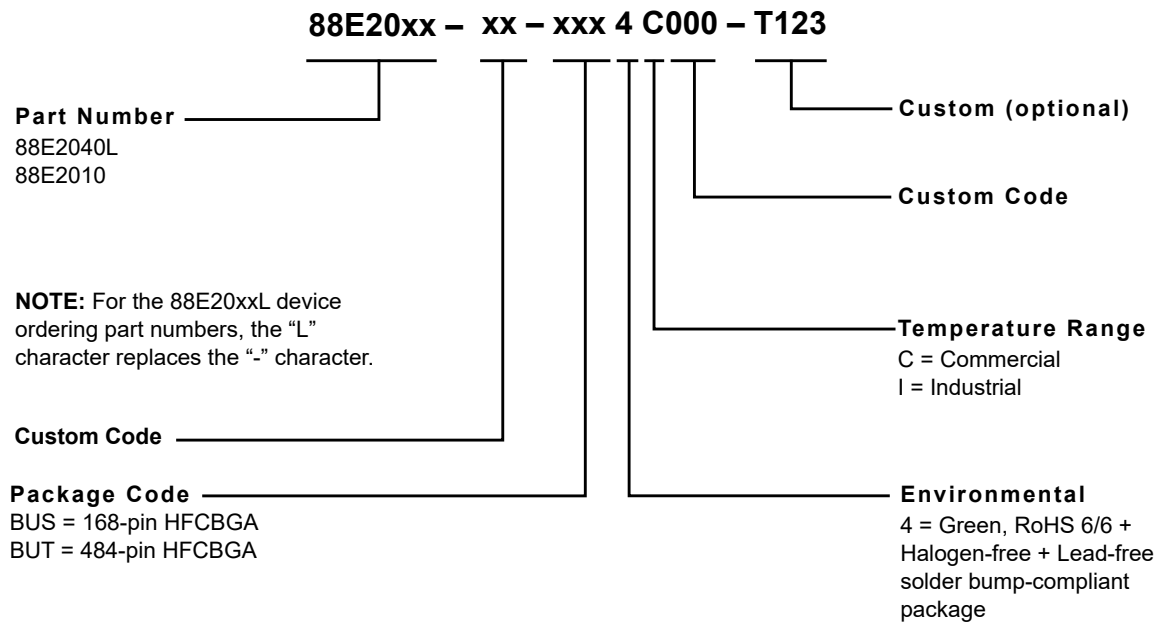

Table 67: 88E2010/88E2040L Commercial Part Order Options

| Part Number | Package Type  | Part Order Number   |
|-------------|---|---------------------|
| 88E2010     | 168-pin 10 mm x 12 mm HFCBGA- Commercial, Green, RoHS 6/6 + Halogen-free + Lead-free solder bump-compliant  | 88E2010-XX-BUS4C000 |
| 88E2040L    | 484-pin 23 mm x 23 mm HFCBGA - Commercial, Green, RoHS 6/6 + Halogen-free + Lead-free solder bump-compliant | 88E2040LXX-BUT4C000 |



**Table 68: 88E2010/88E2040L Industrial Part Order Options**

| Part Number | Package Type   | Part Order Number   |
|-------------|--|---------------------|
| 88E2010     | 168-pin 10 mm x 12 mm HFCBGA- Commercial, Green, RoHS 6/6<br>+ Halogen-free + Lead-free solder bump-compliant  | 88E2010-XX-BUS4I000 |
| 88E2040L    | 484-pin 23 mm x 23 mm HFCBGA - Commercial, Green, RoHS 6/6<br>+ Halogen-free + Lead-free solder bump-compliant | 88E2040LXX-BUT4I000 |



## 8.2 Package Marking

### 8.2.1 Commercial Marking Examples

Figure 36 is an example of the package marking and pin 1 location for the 88E2010 package.

Figure 36: 88E2010 Commercial Package Marking and Pin 1 Location

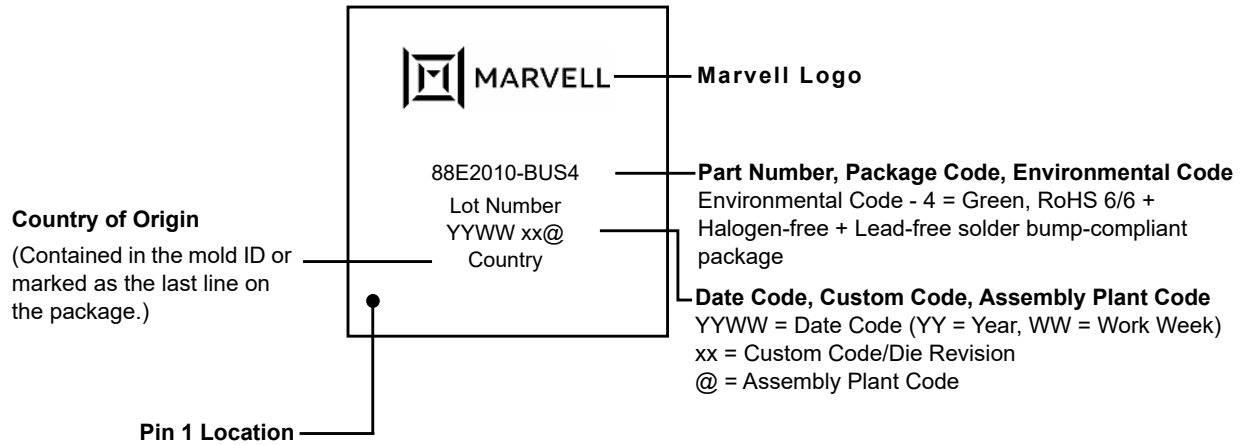

**Note:** The above example is not drawn to scale. Location of markings is approximate.



Figure 37 is an example of the package marking and pin 1 location for the 88E2040L package.

**Figure 37: 88E2040L Commercial Package Marking and Pin 1 Location**

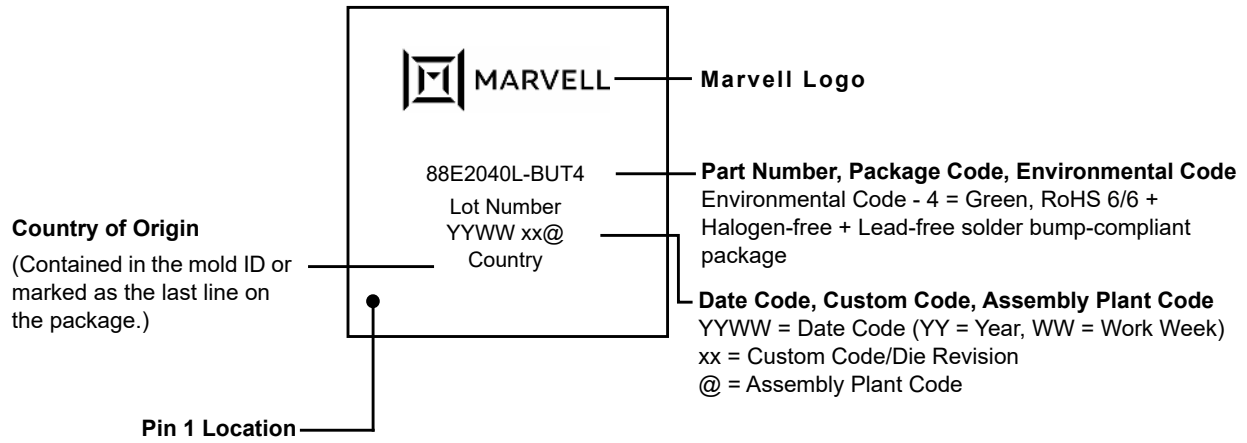

**Note:** The above example is not drawn to scale. Location of markings is approximate.

## 8.2.2 Industrial Marking Examples

Figure 38 is an example of the package marking and pin 1 location for the 88E2010 package.

Figure 38: 88E2010 Industrial Package Marking and Pin 1 Location

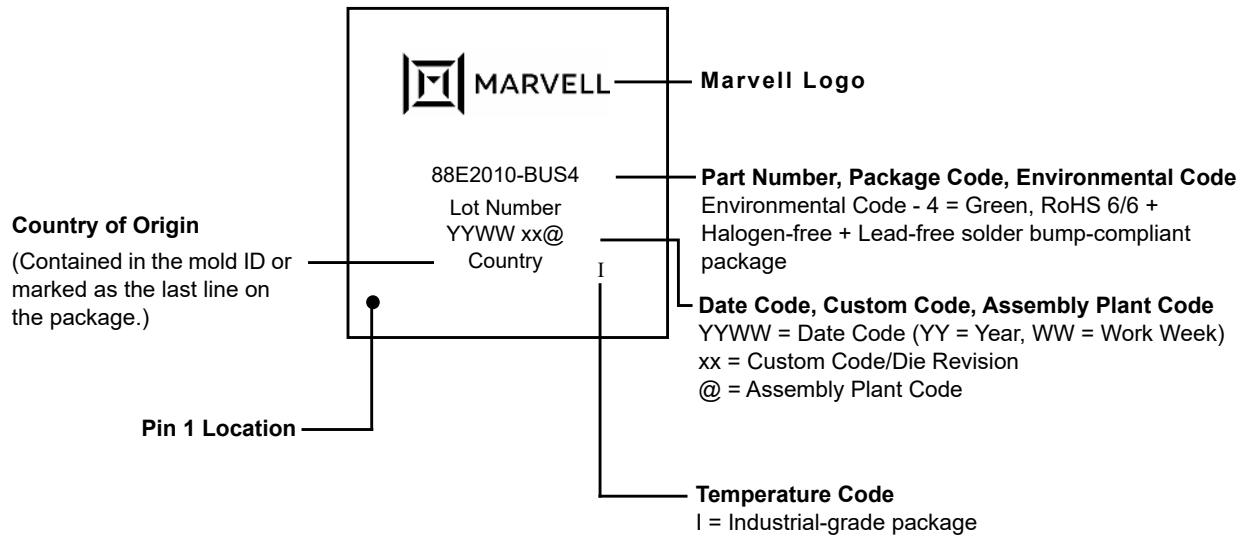

**Note:** The above example is not drawn to scale. Location of markings is approximate.



Figure 39 is an example of the package marking and pin 1 location for the 88E2040L package.

**Figure 39: 88E2040L Industrial Package Marking and Pin 1 Location**

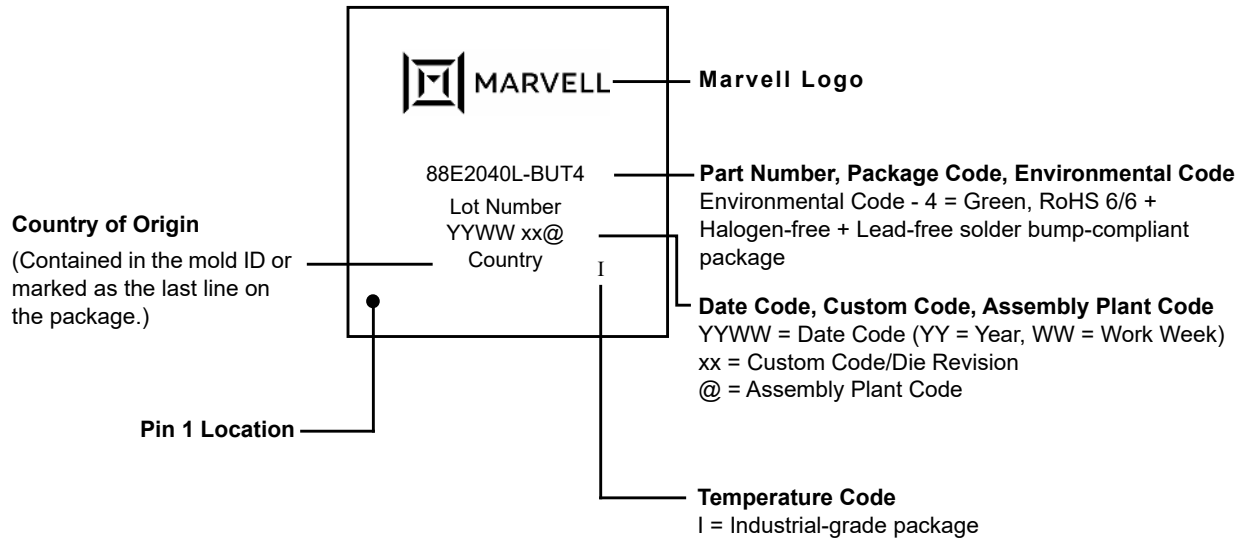

**Note:** The above example is not drawn to scale. Location of markings is approximate.



# Revision History

**Table 69: Document Change History**

| Revision    | Date               | Section                              | Detail   |
|-------------|--------------------|--------------------------------------|--|
| Rev. D      | December 1, 2020   | <b>All applicable</b>                | <ul style="list-style-type: none"> <li>Disclaimer updated</li> <li>Corporate rebranding and template update</li> <li>New Marvell logos added to all figures with Marvell logo marking</li> </ul>   |
| Rev. C      | September 17, 2019 | Revision C released.                 |  |
| Rev. C 3.01 |                    | Section 7, Mechanical Drawing        | <ul style="list-style-type: none"> <li>Figure 31, 168-pin 10 mm x 12 mm HFCBGA Top and Side View, on page 137 updated.</li> <li>Figure 32, 168-pin 10 mm x 12 mm HFCBGA Bottom View, on page 138 updated.</li> <li>Table 65, 168-pin 10 mm x 12 mm HFCBGA Package Dimensions, on page 139 updated.</li> <li>Figure 33, 484-pin 23 mm x 23 mm HFCBGA Top and Side View, on page 140 updated.</li> <li>Figure 34, 484-pin 23 mm x 23 mm HFCBGA Bottom View, on page 141 updated.</li> <li>Table 66, 484-pin 23 mm x 23 mm HFCBGA Package Dimensions, on page 142 updated.</li> </ul> |
| Rev. C 3.00 | October 10, 2018   | Entire document                      | <ul style="list-style-type: none"> <li>Styles and format updated.</li> </ul>   |
| Rev. B 2.08 | September 10, 2018 | Section 6, Electrical Specifications | <ul style="list-style-type: none"> <li>6.5.1 "SGMII Electrical Summary" on page 127 updated.</li> <li>6.5.2 "2500BASE-X Electrical Summary" on page 128 updated.</li> <li>6.5.3 "5GBASE-R Electrical Summary" on page 129 updated.</li> <li>6.5.4 "10BASE-Te, 100BASE-TX, and 1000BASE-T Electrical Parameters" on page 130 updated.</li> <li>6.5.5 "IEEE DC Transceiver Parameters" on page 131 updated.</li> </ul>   |
| Rev. B 2.07 | August 10, 2018    | Entire document                      | <ul style="list-style-type: none"> <li>Styles and format updated.</li> </ul>   |
| Rev. B 2.06 | August 2, 2018     | Cover/Legal                          | <ul style="list-style-type: none"> <li>Legal disclaimer updated.</li> </ul>  |
| Rev. B 2.05 | July 31, 2018      | Section 2, Signal Description        | <ul style="list-style-type: none"> <li>Table 13, 88E2010 Pin List — Alphabetical by Signal Name, on page 39 added.</li> </ul>  |
|             |                    | Section 3, Functional Description    | <ul style="list-style-type: none"> <li>Table 20, Configuration Bit Definition, on page 67 updated.</li> </ul>  |



Table 69: Document Change History (Continued)

| Revision                             | Date   | Section                           | Detail  |
|--------------------------------------|--|-----------------------------------|---|
| Rev. B<br>2.04                       | May 25, 2018   | Product Overview                  | <ul style="list-style-type: none"> <li>Features, on page 3 updated.</li> <li>References to EEE, 802.3az, Long Reach, Clause 22, AVS, WOL, and GPIO removed.</li> </ul>  |
|                                      |  | Section 2, Signal Description     | <ul style="list-style-type: none"> <li>Table 2, Media Dependent Interface, on page 21 through Table 12, Power and Ground (Continued), on page 33 updated.</li> </ul>  |
|                                      |  |                                   | <ul style="list-style-type: none"> <li>Table 10, Adaptive Voltage Scaling Interface (88E2010/P Device Only), on page 49 removed.</li> </ul>   |
|                                      |  | Section 3, Functional Description | <ul style="list-style-type: none"> <li>3.5.1 "Clause 45 MDIO Framing" on page 72 updated.</li> <li>Table 25, Basic LED Status, on page 76 updated.</li> <li>3.8 "Wake On LAN (WOL)" on page 86 removed.</li> <li>3.9 "Long Reach Mode of Operation" on page 86 removed.</li> <li>3.13 "GPIO" on page 94, 3.13.1 "Enabling the GPIO Function" on page 94 and 3.13.3 "GPIO Interrupts" on page 94 removed.</li> <li>3.21 "Adaptive Voltage Scaling (AVS)" on page 134 removed.</li> </ul> |
|                                      |  | Section 4, Copper Unit (T Unit)   | <ul style="list-style-type: none"> <li>4.5 "Energy Efficient Ethernet" on page 140 removed.</li> <li>4.4.1 "802.3 Clause 28, 40, and 55 Auto-Negotiation" on page 102 removed.</li> </ul>   |
| Section 6, Electrical Specifications | <ul style="list-style-type: none"> <li>Table 46, Recommended Operating Conditions, on page 118 updated.</li> </ul> |                                   |   |

**Table 69: Document Change History (Continued)**

| Revision       | Date           | Section                             | Detail  |
|----------------|----------------|-------------------------------------|---|
| Rev. B<br>2.03 | April 24, 2018 | Cover                               | <ul style="list-style-type: none"> <li>Updated title.</li> </ul>  |
|                |                | Product Overview                    | <ul style="list-style-type: none"> <li>Features, on page 3, Figure 1, 88E2010 Top-level Block Diagram, on page 4 and Figure 2, 88E2040L Top-level Block Diagram, on page 5 updated.</li> </ul>  |
|                |                | Section 1, General Chip Description | <ul style="list-style-type: none"> <li>General Chip Description, on page 13, Figure 3, 88E2010 Device Functional Block Diagram, on page 14 and Figure 3, 88E2010 Device Functional Block Diagram, on page 14 updated.</li> </ul>  |
|                |                | Section 2, Signal Description       | <ul style="list-style-type: none"> <li>2.1.1 "88E2010 Device Pin Map" on page 18 and 2.1.2 "88E2040L Device Pin Map" on page 19 updated.</li> </ul>   |
|                |                |                                     | <ul style="list-style-type: none"> <li>Table 2, Media Dependent Interface, on page 21, Table 3, SERDES Interface, on page 23, Table 4, Clock/Reset/Reference, on page 25, Table 5, Management Interface, on page 26, Table 6, SPI Interface, on page 27, and Table 7, LED, on page 28 updated.</li> </ul>   |
|                |                |                                     | <ul style="list-style-type: none"> <li>Table 8, Configuration, on page 29, Table 9, JTAG Interface, on page 29, Table 10, Adaptive Voltage Scaling Interface (88E2010/P Device Only), on page 49, Table 10, Test Pins, on page 30, Table 11, Power and Ground, on page 32, and Table 12, Power and Ground (Continued), on page 33, and Table 13, 88E2010 Pin List — Alphabetical by Signal Name, on page 39 updated.</li> </ul> |
|                |                | Section 3, Functional Description   | <ul style="list-style-type: none"> <li>Figure 5, Device Data Path (88E2040L), on page 54 and Figure 6, Device Data Path (88E2010), on page 55 updated.</li> </ul>   |
|                |                |                                     | <ul style="list-style-type: none"> <li>3.4 "Configuration and Resets" on page 65, 3.4.2 "Hardware Configuration" on page 65, 3.5.3 "Independent MDC/MDIO Support" on page 72, 3.6.2 "Firmware Download to RAM" on page 73, 3.7.1 "Manual Power Down" on page 73, and 3.7.3 "Controlling and Sensing" on page 74 updated.</li> </ul>   |
|                |                |                                     | <ul style="list-style-type: none"> <li>Table 32, 88E2010 Boundary Scan Chain Order, on page 84 and Table 33, 88E2010 Boundary Scan Exclusion List, on page 86 updated.</li> </ul>   |



Table 69: Document Change History (Continued)

| Revision       | Date           | Section   | Detail   |
|----------------|----------------|---|--|
| Rev. B<br>2.02 | April 23, 2018 | Section 3, Functional Description               | <ul style="list-style-type: none"> <li>Table 32, 88E2010 Boundary Scan Chain Order, on page 84 and Table 33, 88E2010 Boundary Scan Exclusion List, on page 86 updated.</li> <li>3.10.6 "ID CODE Instruction" on page 93 updated.</li> </ul>  |
|                |                | Section 5, Host Interface Unit (H Unit)         | <ul style="list-style-type: none"> <li>Host Interface Unit (H Unit), on page 111 updated.</li> <li>5.2 "PCS" on page 112 updated.</li> <li>5.2.1 "5GBASE-R/2500BASE-X" on page 112 updated.</li> <li>5.2.2 "5GBASE-R" on page 112 updated.</li> <li>5.2.3 "2500BASE-X" on page 113 updated.</li> <li>5.2.4 "SGMII (Media)" on page 113 updated.</li> </ul> |
|                |                | Section 6, Electrical Specifications            | <ul style="list-style-type: none"> <li>6.3.1 "Thermal Conditions for 88E2010, 168-pin, HFCBGA Package" on page 119 updated.</li> <li>6.3.2 "Thermal Conditions for 88E2040L, 484-pin, HFCBGA Package" on page 120 updated.</li> <li>6.7 "Latency" on page 135 updated.</li> </ul>  |
|                |                | Section 8, Part Order Numbering/Package Marking | <ul style="list-style-type: none"> <li>Table 67, 88E2010/88E2040L Commercial Part Order Options, on page 143 and Table 68, 88E2010/88E2040L Industrial Part Order Options, on page 144 updated.</li> </ul>   |
| Rev. B<br>2.01 | April 20, 2018 | Initial datasheet draft.                        |  |





Marvell first revolutionized the digital storage industry by moving information at speeds never thought possible. Today, that same breakthrough innovation remains at the heart of the company's storage, networking and connectivity solutions. With leading intellectual property and deep system-level knowledge, Marvell semiconductor solutions continue to transform the enterprise, cloud, automotive, industrial, and consumer markets. For more information, visit [www.marvell.com](http://www.marvell.com).

© 2020 Marvell. All rights reserved. The MARVELL mark and M logo are registered and/or common law trademarks of Marvell and/or its Affiliates in the US and/or other countries. This document may also contain other registered or common law trademarks of Marvell and/or its Affiliates.

Doc. No. MV-S111597-U0 Rev. D Revised: December 1, 2020