

**【1. 適用範囲 SCOPE】**

本仕様書は、\_\_\_\_\_ 殿 に納入する

\_\_\_\_\_ 1.0mm PITCH 電線対基板 コネクタ 1列 \_\_\_\_\_ について規定する。

This specification covers the 1.0 mm PITCH WIRE TO BOARD CONNECTOR 1-ROW series.

**【2. 製品名称及び型番 PRODUCT NAME AND PART NUMBER】**

製品名称 Product Name	製品型番 Part Number
ターミナル Terminal	501334-0*00
リセハウジング Rec Housing	501939-****
ウエハーアセンブリ ストレート Wafer Assembly Straight	501940-****9
501940-****9 エンボス梱包品 (501940-**07以外は乾燥剤入り、ハイバリア梱包) Embossed Tape Packaging For 501940-***9 (Besides 501940-**07 high barrier package including Desiccant)	501940-****7
ウエハーアセンブリ ライトアングル Wafer Assembly Right-Angle	501953-****9
501953-****9 エンボス梱包品 (501953-**07以外は乾燥剤入り、ハイバリア梱包) Embossed Tape Packaging For 501953-***9 (Besides 501953-**07 high barrier package including Desiccant)	501953-****7

\* : 図面参照 Refer to the drawing.

REV.	J								
SHEET	1~16								
REVISE ON PC ONLY					TITLE: 1.0 WIRE TO BOARD CONNECTOR (1-ROW) <b>製品仕様書</b>				
<b>J</b>	変更 REVISED J2015-1447 '15/09/17 T.AKAIKE				THIS DOCUMENT CONTAINS INFORMATION THAT IS PROPRIETARY TO MOLEX INC. AND SHOULD NOT BE USED WITHOUT WRITTEN PERMISSION				
REV.	DESCRIPTION				WRITTEN BY: N.YOSHIDA	CHECKED BY: A.MIZUMURA	APPROVED BY: M.YAGI	DATE : YR/MO/DAY 2005/10/31	
DESIGN CONTROL J			STATUS					FILE NAME PS501940001.doc	SHEET 1 OF 16
DOCUMENT NUMBER <b>PS-501940-001</b>								EN-037(2015-09 rev.4)	

**【3. 定格及び適用電線 RATINGS AND APPLICABLE WIRES】**

項目 Item	規格 Standard	
最大許容電圧 Rated Voltage (MAX.)	50 V	
最大許容電流 Rated Current (MAX.)	AWG#28	1.0A
	AWG#30	1.0A
	AWG#32	0.8A
使用温度範囲 <sup>*1</sup> Ambient Temperature Range	-40°C ~ +105°C <sup>*2*3</sup> 低温において氷結しないこと Not freeze to low temperature	
防湿梱包開梱後の保管条件 Storage condition after opening the Humidity Prevention package 501940-**07、501953-**07 以外に適用	温度 Temperature	-5°C~+35°C
	湿度 Humidity	70%R.H.以下 (但し結露なきこと) 70%R.H.MAX.(No condensation)
	期間 Term	開梱後48時間 For 48 hours after opening the package

\*1 : 基板実装後の無通電状態は、使用温度範囲が適用されます。

Non-operating connectors after reflow must follow the operating temperature range condition.

\*2 : 通電による温度上昇分を含む。

This includes the terminal temperature rise generated by conducting electricity.

\*3 : 適合電線、ケーブル等も本使用温度範囲を満足すること。

Applicable wires and cables must also meet the specified temperature range.

REVISE ON PC ONLY		TITLE:	
<b>J</b>	SEE SHEET 1 OF 16	1.0 WIRE TO BOARD CONN. (1-ROW)	
		<b>製品仕様書</b>	
REV.	DESCRIPTION	THIS DOCUMENT CONTAINS INFORMATION THAT IS PROPRIETARY TO MOLEX INC. AND SHOULD NOT BE USED WITHOUT WRITTEN PERMISSION	
DOCUMENT NUMBER <b>PS-501940-001</b>		FILE NAME PS501940001.doc	SHEET 2 OF 16
EN-037(2015-09 rev.4)			

**【4. 性能 PERFORMANCE】**

4-1.電氣的性能 Electrical performance

項 目 Item		条 件 Test Condition	規 格 Requirement
4-1-1	接 触 抵 抗 Contact Resistance	コネクタを嵌合させ、開放電圧 20mV以下、短絡電流 10mA にて測定する。 (JIS C5402 5.4)  Mate connectors and measured by dry circuit, 20mV MAX., 10mA. (JIS C5402 5.4)	20 milliohms MAX.
4-1-2	絶 縁 抵 抗 Insulation Resistance	コネクタを嵌合させ、隣接するターミナル間及びターミナル、アース間に、DC 500Vを印加し測定する。 (JIS C5402 5.2/MIL-STD-202 試験法 302)  Mate connectors and apply 500V DC between adjacent terminal or ground. (JIS C5402 5.2/MIL-STD-202 Method 302)	100 Megohms MIN.
4-1-3	耐 電 圧 Dielectric Strength	コネクタを嵌合させ、隣接するターミナル間及びターミナル、アース間に、AC(rms) 250V (実効値) を1分間 印加する。 (JIS C5402 5.1/MIL-STD-202 試験法 301)  Mate connectors and apply 250V AC(rms) for 1 minute between adjacent terminal or ground. (JIS C5402 5.1/MIL-STD-202 Method 301)	異状なきこと No Breakdown
4-1-4	圧着部接触抵抗 Contact Resistance on Crimped Portion	ターミナルに適合電線を圧着し、開放電圧20mV以下、短絡電流 10mA にて測定する。  Crimp the applicable wire to the terminal, measured by dry circuit, 20mV MAX., 10mA.	5 milliohms MAX.

REVISE ON PC ONLY		TITLE:	
<b>J</b>	SEE SHEET 1 OF 16	1.0 WIRE TO BOARD CONN. (1-ROW)	
		<b>製品仕様書</b>	
REV.	DESCRIPTION	THIS DOCUMENT CONTAINS INFORMATION THAT IS PROPRIETARY TO MOLEX INC. AND SHOULD NOT BE USED WITHOUT WRITTEN PERMISSION	
DOCUMENT NUMBER <b>PS-501940-001</b>		FILE NAME PS501940001.doc	SHEET 3 OF 16
EN-037(2015-09 rev.4)			

4-2. 機械的性能 Mechanical Performance

項目 Item		条件 Test Condition		規格 Requirement
4-2-1	挿入力及び抜去力 Insertion and Withdrawal Force	毎分 25±3mm の速さで挿入、抜去を行う。 Insert and withdraw connectors at the speed rate of 25±3 mm/minute.		第6項参照 Refer to paragraph 6
4-2-2	圧着部引張強度 Crimping Pull out Force	圧着されたターミナルを治具に固定し、電線を軸方向に毎分25±3mmの速さで引張る。 (JIS C5402 6.8) Fix the crimped terminal, apply axial pull out force on the wire at the speed rate of 25±3mm/minute. (JIS C5402 6.8)	AWG#28	9.8N{1.0kgf}MIN.
			AWG#30	4.9N{0.5kgf}MIN.
			AWG#32	3.0N{0.3kgf}MIN.
4-2-3	ターミナル挿入力 Terminal Insertion Force	圧着されたターミナルをハウジングに挿入する。 Insert the crimped terminal into the housing.		4.9N {0.5 kgf} MAX.
4-2-4	ターミナル保持力 Terminal / Housing Retention Force	ハウジングに装着されたターミナルを毎分 25±3mm の速さで引張る。 Apply axial pull out force at the speed rate of 25±3mm/minute on the terminal assembled in the housing.		4.9N {0.5 kgf} MIN.
4-2-5	ピン保持力 Pin Retention Force	ウエハーに装着されたピンを毎分 25±3mm の速さで軸方向に押す。 Apply axial push force at the speed rate of 25±3mm/minute on the pin assembled in the wafer.		2.94N {0.3 kgf} MIN.
4-2-6	ハウジングロック強度 Housing Lock Strength	3CKT.	ハウジングを嵌合し、軸方向に9.8N{1.0kgf}の力で引張る。 Mated connectors, and apply axial pull out force of 9.8N.	異状なきこと No Damage
		4・5CKT	ハウジングを嵌合し、軸方向に19.6N{2.0kgf}の力で引張る。 Mated connectors, and apply axial pull out force of 19.6N.	

REVISE ON PC ONLY		TITLE:  1.0 WIRE TO BOARD CONN. (1-ROW)  <b>製品仕様書</b>
<b>J</b>	SEE SHEET 1 OF 16	
REV.	DESCRIPTION	THIS DOCUMENT CONTAINS INFORMATION THAT IS PROPRIETARY TO MOLEX INC. AND SHOULD NOT BE USED WITHOUT WRITTEN PERMISSION

DOCUMENT NUMBER  
**PS-501940-001**

FILE NAME  
PS501940001.doc

SHEET  
4 OF 16

## 4-3. その他 Environmental Performance and Others

項目 Item		条件 Test Condition	規格 Requirement	
4-3-1	挿抜寿命 Repeated Insertion / Withdrawal	1分間 10回 以下の速さで挿入、抜去を30回 繰返す。  When mated up to 30 cycles repeatedly by the rate of 10 cycles per minute.	接触抵抗 Contact Resistance	40 milliohms MAX.
4-3-2	温度上昇 Temperature Rise	コネクタを嵌合させ、最大許容電流を通电し、コネクタの温度上昇分を測定する。(UL 498)  Carrying rated current load. (UL 498)	温度上昇 Temperature Rise	30 °C MAX.
4-3-3	耐振動性 Vibration	DC 1mA 通电状態にて、嵌合軸を含む互いに垂直な 3方向に 掃引割合 10~55~10 Hz/分、全振幅 1.52mm の振動を各2時間 加える。 (MIL-STD-202 試験法 201)  Amplitude : 1.52mm P-P Frequency : 10~55~10 Hz in 1 minute. Duration : 2 hours in each X.Y.Z.axes. (MIL-STD-202 Method 201)	外観 Appearance	異常なきこと No Damage
			接触抵抗 Contact Resistance	40 milliohms MAX.
			瞬断 Discontinuity	1 microsecond MAX.
4-3-4	耐衝撃性 Mechanical Shock	DC 1mA 通电状態にて、嵌合軸を含む互いに垂直な 6方向に 490m/s <sup>2</sup> { 50G } の衝撃を各3回 加える。 (JIS C60068-2-27/MIL-STD-202 試験法213)  490m/s <sup>2</sup> { 50G } , 3 strokes in each X.Y.Z. axes. (JIS C60068-2-27/MIL-STD-202 Method 213)	外観 Appearance	異常なきこと No Damage
			接触抵抗 Contact Resistance	40 milliohms MAX.
			瞬断 Discontinuity	1 microsecond MAX.
4-3-5	耐熱性 Heat Resistance	コネクタを嵌合させ、105±2°C の雰囲気中に96時間放置後取り出し、1時間 室温に放置する。 (JIS C60068-2-2/MIL-STD-202 試験法 108)  105±2°C, 96 hours (JIS C60068-2-2/MIL-STD-202 Method 108)	外観 Appearance	異常なきこと No Damage
			接触抵抗 Contact Resistance	40 milliohms MAX
4-3-6	耐寒性 Cold Resistance	コネクタを嵌合させ、-40±3°C の雰囲気中に96時間 放置後取り出し、1時間 室温に放置する。 (JIS C60068-2-1)  -40±3°C, 96 hours (JIS C60068-2-1)	外観 Appearance	異常なきこと No Damage
			接触抵抗 Contact Resistance	40 milliohms MAX.

REVISE ON PC ONLY

**J**

SEE SHEET 1 OF 16

TITLE:

 1.0 WIRE TO BOARD CONN.  
(1-ROW)

**製品仕様書**

THIS DOCUMENT CONTAINS INFORMATION THAT IS PROPRIETARY TO MOLEX INC. AND SHOULD NOT BE USED WITHOUT WRITTEN PERMISSION

REV.

DESCRIPTION

 DOCUMENT NUMBER  
**PS-501940-001**

 FILE NAME  
PS501940001.doc

 SHEET  
5 OF 16

項 目 Item		条 件 Test Condition	規 格 Requirement	
4-3-7	耐湿性 Humidity	コネクタを嵌合させ、60±2°C、相対湿度90~95%の雰囲気中に96時間放置後取り出し、1時間室温に放置する。 (JIS C60068-2-3/MIL-STD-202 試験法 103)  Temperature : 60±2°C Relative Humidity : 90~95% Duration : 96 hours (JIS C60068-2-3/MIL-STD-202 Method 103)	外 観 Appearance	異常なきこと No Damage
			接 触 抵 抗 Contact Resistance	40 milliohms MAX.
			耐 電 圧 Dielectric Strength	4-1-3項満足のこと Must meet 4-1-3
			絶 縁 抵 抗 Insulation Resistance	10 Megohms MIN.
4-3-8	温度サイクル Temperature Cycling	コネクタを嵌合させ、-55°Cに30分、+105°Cに30分これを1サイクルとし、5サイクル繰返す。但し、温度移行時間は5分以内とする。試験後1~2時間室温に放置する。 (JIS C0025)  5 cycles of : a) -55°C 30 minutes b) +105°C 30 minutes (JIS C0025)	外 観 Appearance	異常なきこと No Damage
			接 触 抵 抗 Contact Resistance	40 milliohms MAX.
4-3-9	塩水噴霧 Salt Spray	コネクタを嵌合させ、35±2°Cにて5±1%重量比の塩水を48±4時間噴霧し、試験後常温で水洗いした後、室温で乾燥させる。 (JIS C60068-2-11/MIL-STD-202 試験法101)  48±4 hours exposure to a salt spray from the 5±1% solution at 35±2°C. (JIS C60068-2-11/MIL-STD-202 Method101)	外 観 Appearance	異常なきこと No Damage
			接 触 抵 抗 Contact Resistance	40 milliohms MAX.
4-3-10	亜硫酸ガス SO <sub>2</sub> Gas	コネクタを嵌合させ、40±2°Cにて50±5ppmの亜硫酸ガス中に24時間放置する。  24 hours exposure to 50±5ppm SO <sub>2</sub> gas at 40±2°C.	外 観 Appearance	異常なきこと No Damage
			接 触 抵 抗 Contact Resistance	40 milliohms MAX.
4-3-11	耐アンモニア性 NH <sub>3</sub> Gas	コネクタを嵌合させ、濃度28%のアンモニア水を入れた容器中に40分間放置する。 (1Lに対して25mLの割合)  40 minutes exposure to NH <sub>3</sub> gas evaporating from 28% Ammonia solution.	外 観 Appearance	異常なきこと No Damage
			接 触 抵 抗 Contact Resistance	40 milliohms MAX.

REVISE ON PC ONLY		TITLE:  1.0 WIRE TO BOARD CONN. (1-ROW)  <b>製品仕様書</b>
<b>J</b>	SEE SHEET 1 OF 16	
REV.	DESCRIPTION	THIS DOCUMENT CONTAINS INFORMATION THAT IS PROPRIETARY TO MOLEX INC. AND SHOULD NOT BE USED WITHOUT WRITTEN PERMISSION

DOCUMENT NUMBER <b>PS-501940-001</b>	FILE NAME PS501940001.doc	SHEET 6 OF 16
---	------------------------------	------------------

項 目 Item		条 件 Test Condition	規 格 Requirement	
4-3-12	半田付け性 Solder ability	端子先端及び金具先端より0.5mm迄、 245±3℃の半田に3±0.5秒浸す。 Soldering Time: 3±0.5seconds Solder Temperature: 245±3℃ 0.5mm from terminal tip and fitting nail tip.	濡れ性 Solder Wetting	浸漬面積の 90%以上 90% of immersed area must show no voids,pin holes.
4-3-13	半田耐熱性 Resistance to Soldering Heat	リフロー時 第7項の条件にて行う。  <u>Refer soldering method</u> See paragraph 7.	外 観 Appearance	端子ガタ、割れ等 異状なきこと No Damage
		手半田時 端子先端及び金具先端より0.2mmの位置ま で、370~400℃の半田ゴテにて 3±1秒以下加熱する。  <u>Soldering iron method</u> 0.2mm from terminal tip Solder Temperature : 370~400℃ Soldering Time :3±1 seconds MAX.		

( ) :参考規格 Reference Standard  
{ } :参考単位 Reference Unit

\* 各項目の評価サンプルは、製品図面に記載されている推奨基板レイアウト、推奨メタルマスクにて実装しています。リフロー条件は4-3-14の推奨温度プロファイルにて実装しております。半田ペーストは、無鉛半田 (Sn-3Ag-0.5Cu) を使用しています。

The evaluation samples of each specification test are reflowed according to the recommended Print Circuit Board layout and the recommended metal mask thickness specified in the sales drawing. The reflow conditions followed are specified in the reflow profile in section 4-3-14. Lead free solder (Sn-3Ag-0.5Cu) was used as the soldering paste.

【5. 外観形状、寸法及び材質 PRODUCT SHAPE, DIMENSIONS AND MATERIALS】

図面参照 Refer to the drawing.

REVISE ON PC ONLY		TITLE:	
<b>J</b>	SEE SHEET 1 OF 16	1.0 WIRE TO BOARD CONN. (1-ROW)	
		<b>製品仕様書</b>	
REV.	DESCRIPTION	THIS DOCUMENT CONTAINS INFORMATION THAT IS PROPRIETARY TO MOLEX INC. AND SHOULD NOT BE USED WITHOUT WRITTEN PERMISSION	
DOCUMENT NUMBER <b>PS-501940-001</b>		FILE NAME PS501940001.doc	SHEET 7 OF 16



**【6. 挿入力及び抜去力 INSERTION / WITHDRAWAL FORCE】**

ロック形状 Lock Shape	極 数 No. of CKT	単位 UNIT	挿入力(最大値) Insertion (MAX.)			抜去力(最小値) Withdrawal (MIN.)		
			初回 1st	6回目 6th	30回目 30th	初回 1st	6回目 6th	30回目 30th
アウター ポジティブロック Outer Positive Lock	3	N {kgf}	8.83 {0.9}	8.83 {0.9}	8.83 {0.9}	0.59 {0.06}	0.59 {0.06}	0.59 {0.06}
	4	N {kgf}	11.8 {1.2}	11.8 {1.2}	11.8 {1.2}	0.78 {0.08}	0.78 {0.08}	0.78 {0.08}
	5	N {kgf}	14.7 {1.5}	14.7 {1.5}	14.7 {1.5}	0.98 {0.10}	0.98 {0.10}	0.98 {0.10}

※ ポジティブロックはロックを解除して測定 Released positive lock, and measure.

{ } :参考単位 Reference Unit

REVISE ON PC ONLY		TITLE:	
<b>J</b>	SEE SHEET 1 OF 16	1.0 WIRE TO BOARD CONN. (1-ROW)	
	REV.	DESCRIPTION	製品仕様書
DOCUMENT NUMBER <b>PS-501940-001</b>		THIS DOCUMENT CONTAINS INFORMATION THAT IS PROPRIETARY TO MOLEX INC. AND SHOULD NOT BE USED WITHOUT WRITTEN PERMISSION	
		FILE NAME PS501940001.doc	SHEET 8 OF 16
EN-037(2015-09 rev.4)			



【7. 赤外線リフロー条件 INFRARED REFLOW CONDITION】

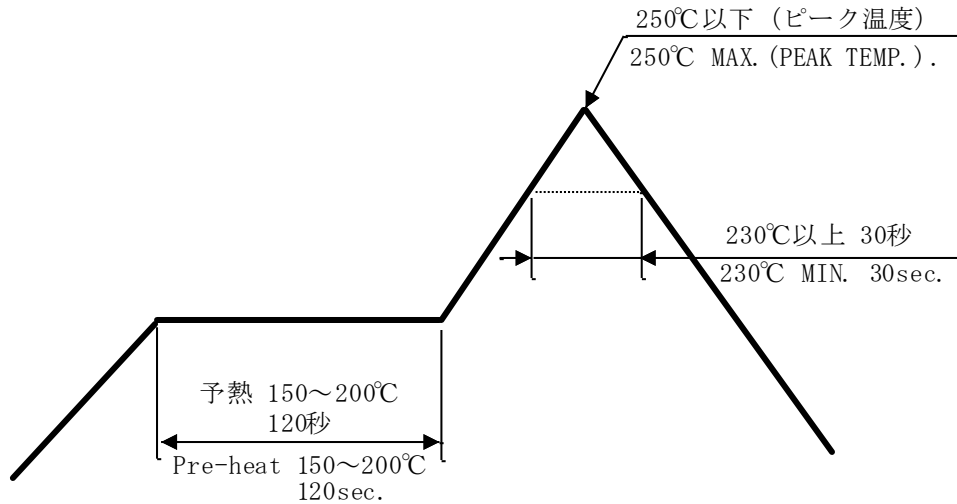

温度条件グラフ  
TEMPERATURE CONDITION GRAPH  
(基板表面温度)  
(TEMPERATURE ON BOARD PATTERN SIDE)

注記: 本リフロー条件に関しては、リフロー装置及び基板などにより条件が異なりますので  
 事前に実装評価(リフロー評価)の御確認を御願ひ致します。  
 フィッティングネイルが変色する場合がございますが、半田付け性には問題ありません。  
 NOTE : Please check the mount condition (reflow soldering condition) by your own devices  
 beforehand, because the condition changes by the soldering devices, p.c. boards, and so on.  
 Although fitting nail may discolors, a solderability does not have a problem

【8. 注記 NOTES】

本製品のプラスチック部に黒点、気泡等が確認される場合や色合いが異なる場合（経年変化によるハウジング変色を含む）がありますが、製品性能に影響はありません。

There is no influence in the product performance though the black spot or bubble etc. might be confirmed to the plastic part of this product and the shade might be different (discoloration by secular distortion etc.).

REVISE ON PC ONLY		TITLE:	
<b>J</b>	SEE SHEET 1 OF 16	1.0 WIRE TO BOARD CONN. (1-ROW)	
	REV.	DESCRIPTION	製品仕様書
		THIS DOCUMENT CONTAINS INFORMATION THAT IS PROPRIETARY TO MOLEX INC. AND SHOULD NOT BE USED WITHOUT WRITTEN PERMISSION	
DOCUMENT NUMBER <b>PS-501940-001</b>		FILE NAME PS501940001.doc	SHEET 9 OF 16
EN-037(2015-09 rev.4)			

**【9. 取り扱い上の注意事項 INSTRUCTION UPON USAGE】**

1. ポジティブロックタイプコネクタの嵌合を取り外す際は、必ずロックを解除して行って下さい。  
When unmated positive lock type connectors, positive locks shall be released.
2. 嵌合時にリセハウジングの矢印で示す部位を押し嵌合して下さい。  
電線やハウジングのロック部を押した場合、これらが破損する恐れがありますのでお避け下さい。  
Please push the part directed by FIG.1 at the time of mate.  
It may damage, when electric wires or lock part of the receptacle housing are pushed.

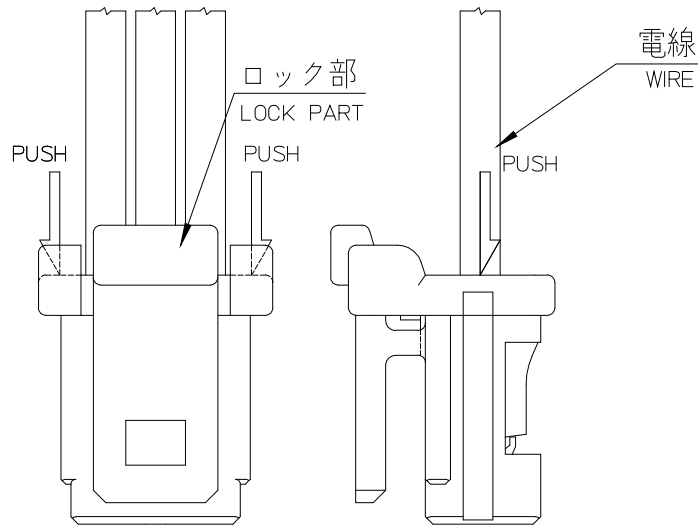

501939-\*\*00

図 1 .  
**FIG.1**

3. 本製品のハウジングには、ナイロン系樹脂を使用しているため、使用環境によっては吸水の可能性があります。  
3%以上の吸水で、機械的物性が変化する場合があります。  
Because the receptacle housings are formed from nylon resin,  
they may absorb water from the ambient environment.  
Mechanical Performance may change when they absorb water over 3%.

REVISE ON PC ONLY		TITLE:	
<b>J</b>	SEE SHEET 1 OF 16	1.0 WIRE TO BOARD CONN. (1-ROW)	
	REV.	DESCRIPTION	製品仕様書
DOCUMENT NUMBER <b>PS-501940-001</b>		THIS DOCUMENT CONTAINS INFORMATION THAT IS PROPRIETARY TO MOLEX INC. AND SHOULD NOT BE USED WITHOUT WRITTEN PERMISSION	
		FILE NAME PS501940001.doc	SHEET 10 OF 16
EN-037(2015-09 rev.4)			

4. 本製品の樹脂部に多少の傷や、めっきの色相が異なる事がありますが、製品性能には影響ございません。  
Although this product may have a weld line or a scratch on the housing, and a different color condition of plating, these will not have any influence on the product's performance.
  
5. 本製品のハウジング及びメッキ表面に多少の傷が確認される場合がありますが、製品性能に問題ありません。  
A few scratch may be confirmed to the surface of the housing and the plating of this product, however, There is no problem in the product performance.
  
6. 本製品のプラスチック部に紫外線により変色する場合がありますが、製品性能に問題ありません。  
Discoloration of the plastic part of this product can result from exposure to ultraviolet light. There is no problem in the product performance.

<b>J</b>	REVISE ON PC ONLY	SEE SHEET 1 OF 16	TITLE: 1.0 WIRE TO BOARD CONN. (1-ROW) <b>製品仕様書</b>	
	REV.		DESCRIPTION	THIS DOCUMENT CONTAINS INFORMATION THAT IS PROPRIETARY TO MOLEX INC. AND SHOULD NOT BE USED WITHOUT WRITTEN PERMISSION
DOCUMENT NUMBER <b>PS-501940-001</b>			FILE NAME PS501940001.doc	SHEET 11 OF 16
EN-037(2015-09 rev.4)				

【10. 圧着端子取り扱い上の注意事項 INSTRUCTION UPON USAGE OF CRIMP TERMINAL】

- 保管する場合には、外装カートン表示に従って保管願ます。縦置き又は、天地逆に保管すると巻き緩みの原因になります。  
When storing crimp terminal, please follow the view of outer carton. Do not store in an upright position or upside down. It could loosen the terminal.



図1 端子梱包に関する各部名称  
FIG.1. NOMENCLATURE FOR THE TERMINAL PACKAGING

- 保管環境に著しい高温・湿度がある場合、端子表面層に錆等の影響を及ぼす事がありますのでご注意願います。  
When storing the terminal in the significant temperature or, humidity, may be affected at the terminal surface.

REVISE ON PC ONLY		TITLE:	
<b>J</b>	SEE SHEET 1 OF 16	1.0 WIRE TO BOARD CONN. (1-ROW)	
		<b>製品仕様書</b>	
REV.	DESCRIPTION	THIS DOCUMENT CONTAINS INFORMATION THAT IS PROPRIETARY TO MOLEX INC. AND SHOULD NOT BE USED WITHOUT WRITTEN PERMISSION	
DOCUMENT NUMBER <b>PS-501940-001</b>		FILE NAME PS501940001.doc	SHEET 12 OF 16
EN-037(2015-09 rev.4)			

3. 輸送、運搬時、カートン内リール数が規定梱包数量に満たない場合には、リールに衝撃を与えぬ様に緩衝材を入れガタつき防止を行って下さい。  
When number of reel in carton less than the prescribed quantity, prevent looseness with adding the cushion, during transport, conveyance.

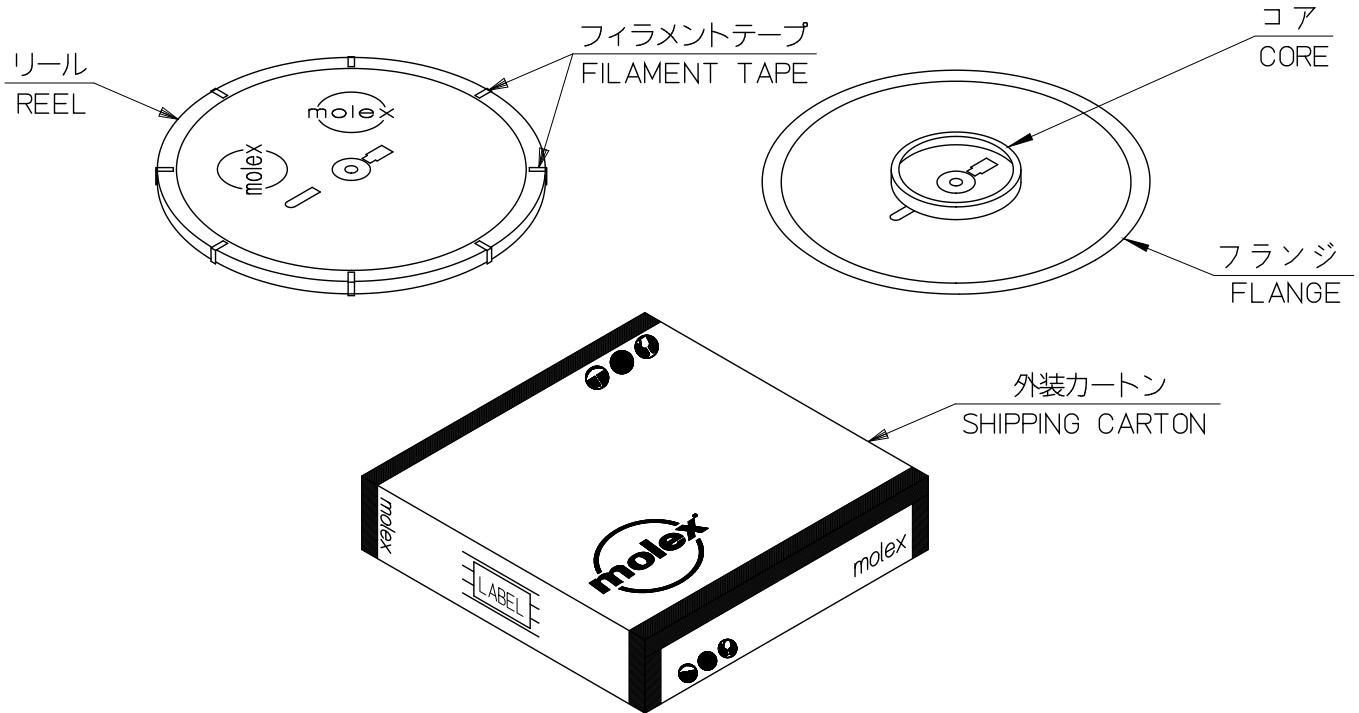

図2 カートン内リール数が規定梱包数量に満たない場合の梱包方法  
FIG.2 PACKAGING METHOD, IN CASE OF NUMBER OF REEL  
IN CARTON LESS THAN THE PRESCRIBED QUANTITY

REVISE ON PC ONLY		TITLE:	
<b>J</b>	SEE SHEET 1 OF 16	1.0 WIRE TO BOARD CONN. (1-ROW)	
REV.	DESCRIPTION	製品仕様書	
		THIS DOCUMENT CONTAINS INFORMATION THAT IS PROPRIETARY TO MOLEX INC. AND SHOULD NOT BE USED WITHOUT WRITTEN PERMISSION	
DOCUMENT NUMBER <b>PS-501940-001</b>		FILE NAME PS501940001.doc	SHEET 13 OF 16
EN-037(2015-09 rev.4)			

4. カートンからリールを取り出す際は、両側フランジを持ち取り出して下さい。片面だけを掴んだ場合端子自重によりコア部からフランジ面が剥がれる恐れがあります。  
When removing the reel from the carton, please remove with holding the flange on both sides. Do not grab only one side. It could detach the flange from the core.

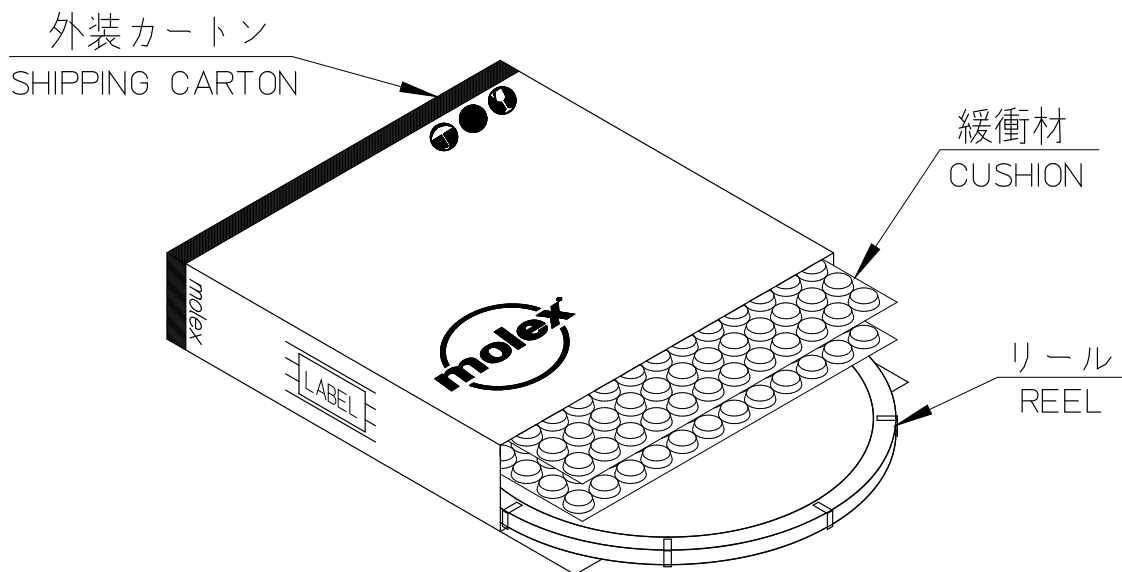

図3 リールの取り出し方法  
FIG.3 METHOD OF REMOVING THE REEL FROM THE CARTON

REVISE ON PC ONLY		TITLE:	
<b>J</b>	SEE SHEET 1 OF 16	1.0 WIRE TO BOARD CONN. (1-ROW)	
		<b>製品仕様書</b>	
REV.	DESCRIPTION	THIS DOCUMENT CONTAINS INFORMATION THAT IS PROPRIETARY TO MOLEX INC. AND SHOULD NOT BE USED WITHOUT WRITTEN PERMISSION	
DOCUMENT NUMBER <b>PS-501940-001</b>		FILE NAME PS501940001.doc	SHEET 14 OF 16
EN-037(2015-09 rev.4)			

5. カートンよりリールを取り出し保管される場合には、キャリア側を下側にし保管願います。  
 キャリア側を上にし、保管されますと端子自重により巻き緩みが発生する恐れがあります。  
 When storing the terminal with remove the reel from the carton, please keep carrier down side. Do not keep carrier up side. It could loosen the terminal.

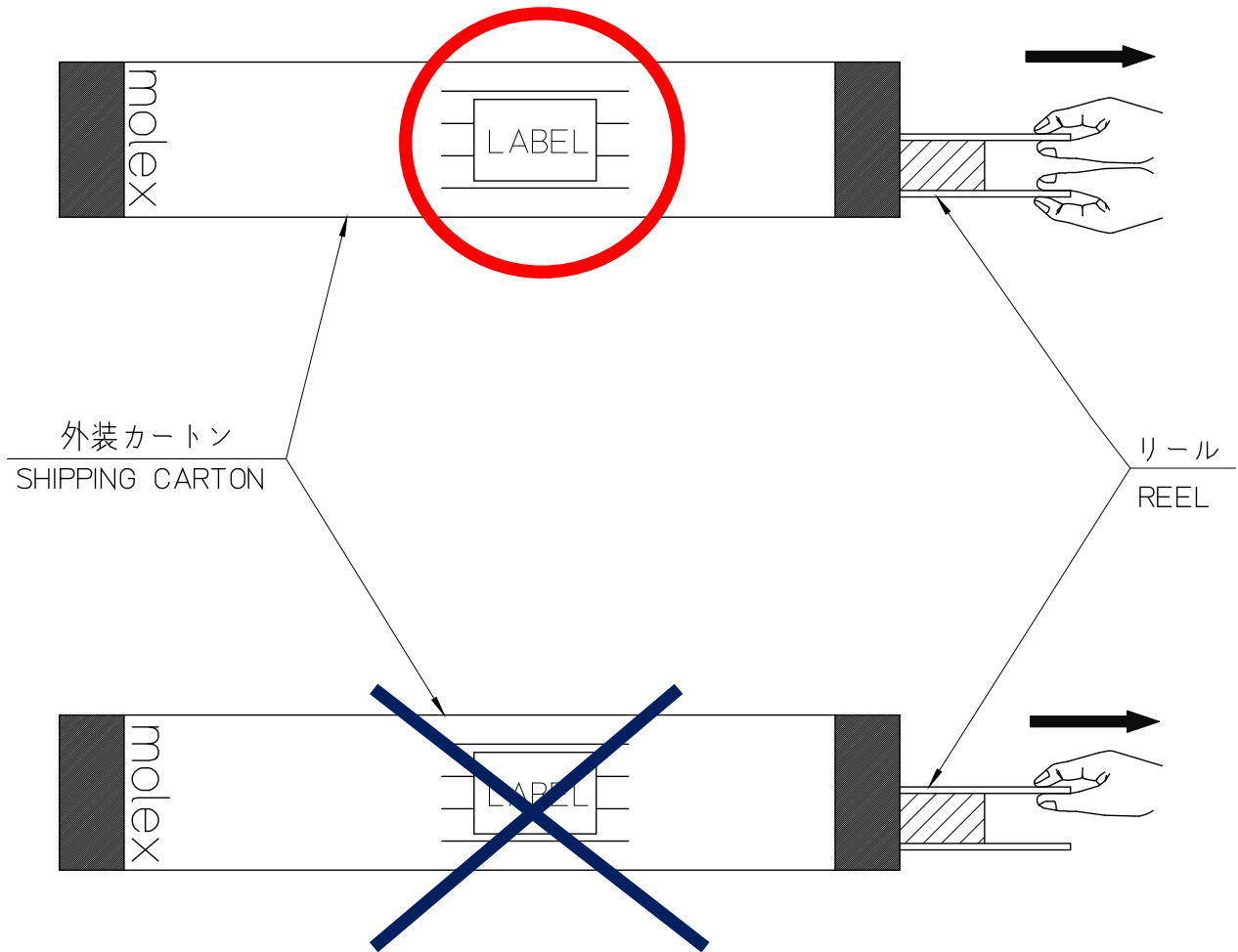

図4リール保管時の向き  
 FIG.4 DIRECTION OF THE REEL STORAGE

6. 圧着機へリールを長時間掛けた状態でいますと、端子自重により巻き緩みが発生する恐れがあります。  
 ご使用にならない場合には、中間紙で端子全周を2~3周巻いた後、巻き緩みが生じない様、中間紙先端、フランジ間のテープ止めをし、キャリア側を下にし保管願います。  
 Do not put the reel in the crimping machine for long period. It could loosen the terminal. When it is not used, after rolling interleaf twice, or three times into terminal all around, please keep carrier down side, with taping tip of the interleaf and flange.
7. 圧着仕様を満足する為に、当社推奨圧着機のご使用をお願い致します。  
 In order to meet the crimp specification, please use our recommended crimping machine.
8. 外装カートン組立及び、中間紙繋ぎにステープル(ホチキス)は、使用しないで下さい。  
 Stapler prohibited in whole area with outer carton assembly, linking the interleaf .

【11. 環境指令への適合 COMPLIANCE WITH ENVIRONMENTAL DIRECTIVE】

1. ELV及びRoHS適合品  
 ELV and RoHS Compliant

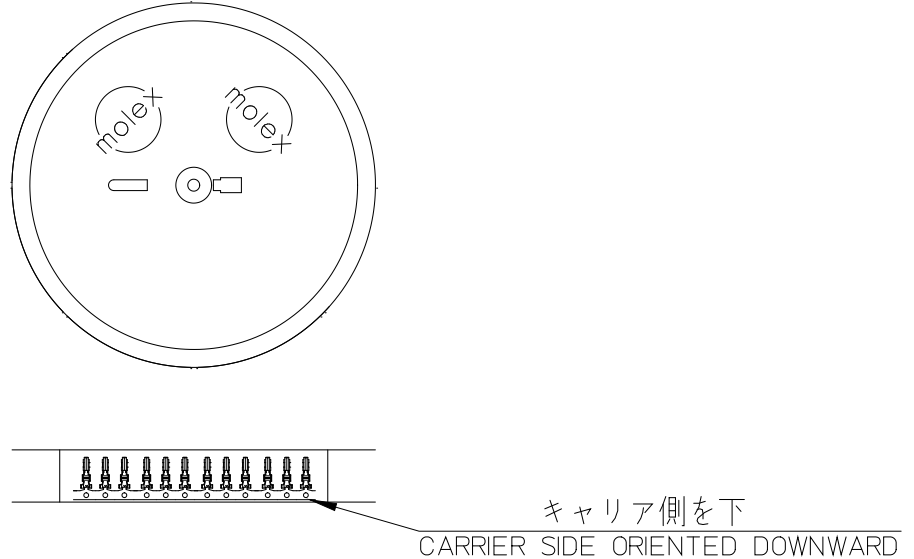
REVISE ON PC ONLY		TITLE:	
<b>J</b>	SEE SHEET 1 OF 16	1.0 WIRE TO BOARD CONN. (1-ROW)	
	REV.	DESCRIPTION	製品仕様書
		THIS DOCUMENT CONTAINS INFORMATION THAT IS PROPRIETARY TO MOLEX INC. AND SHOULD NOT BE USED WITHOUT WRITTEN PERMISSION	
DOCUMENT NUMBER <b>PS-501940-001</b>		FILE NAME PS501940001.doc	SHEET 15 OF 16
EN-037(2015-09 rev.4)			



