

PART NUMBER CODING
SWT201-UP_N-S01-UU-UU

PLATING

E = TIN OVERALL.
P = GOLD FLASH OVERALL.

REVISIONS				
REV.	ECO. NO	DESCRIPTION	DATE	BY
A	2003	INITIAL RELEASE	9/08/2009	JH

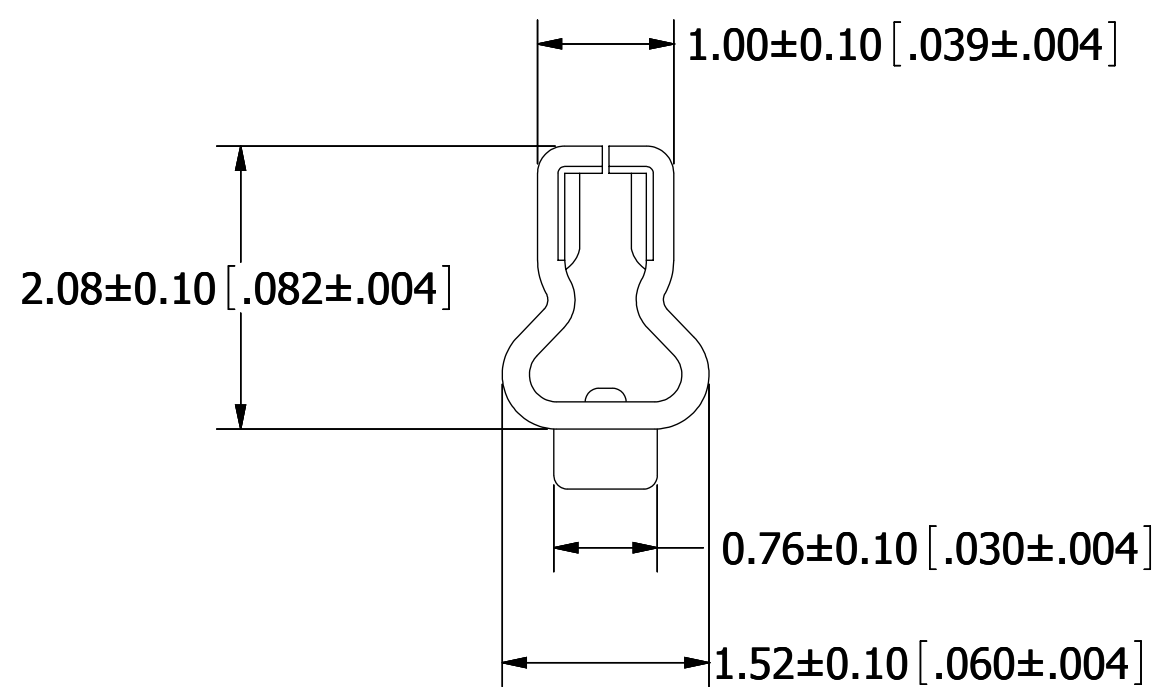
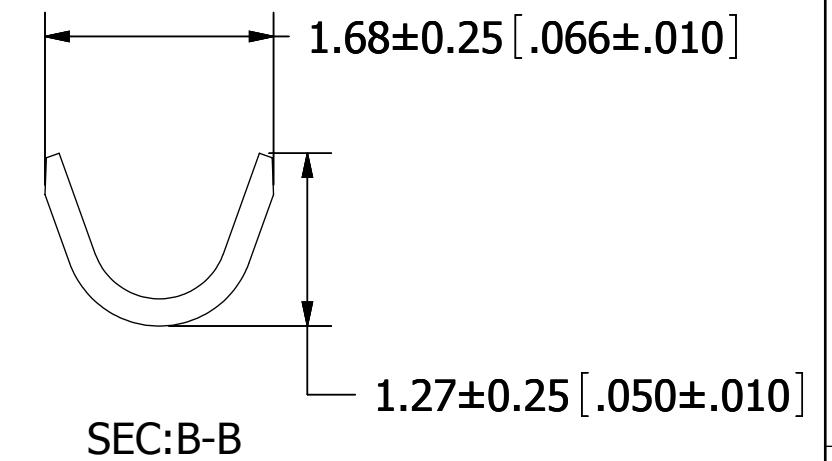
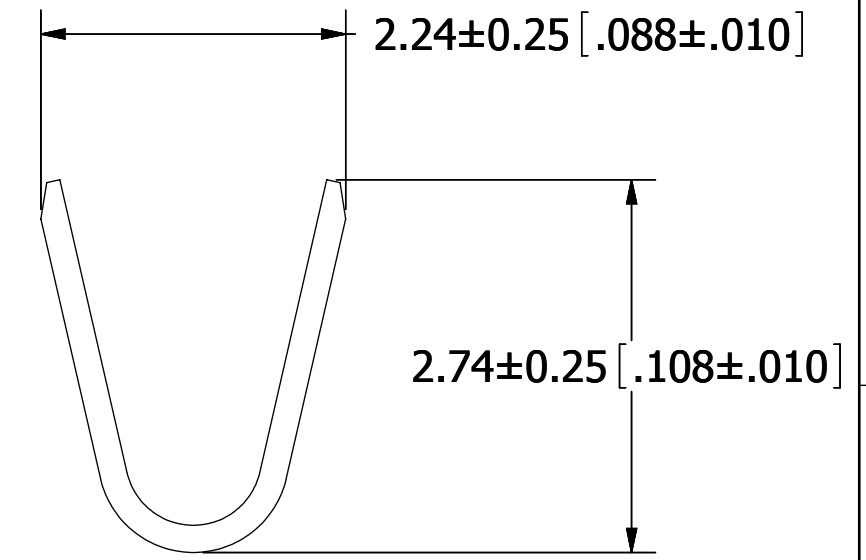
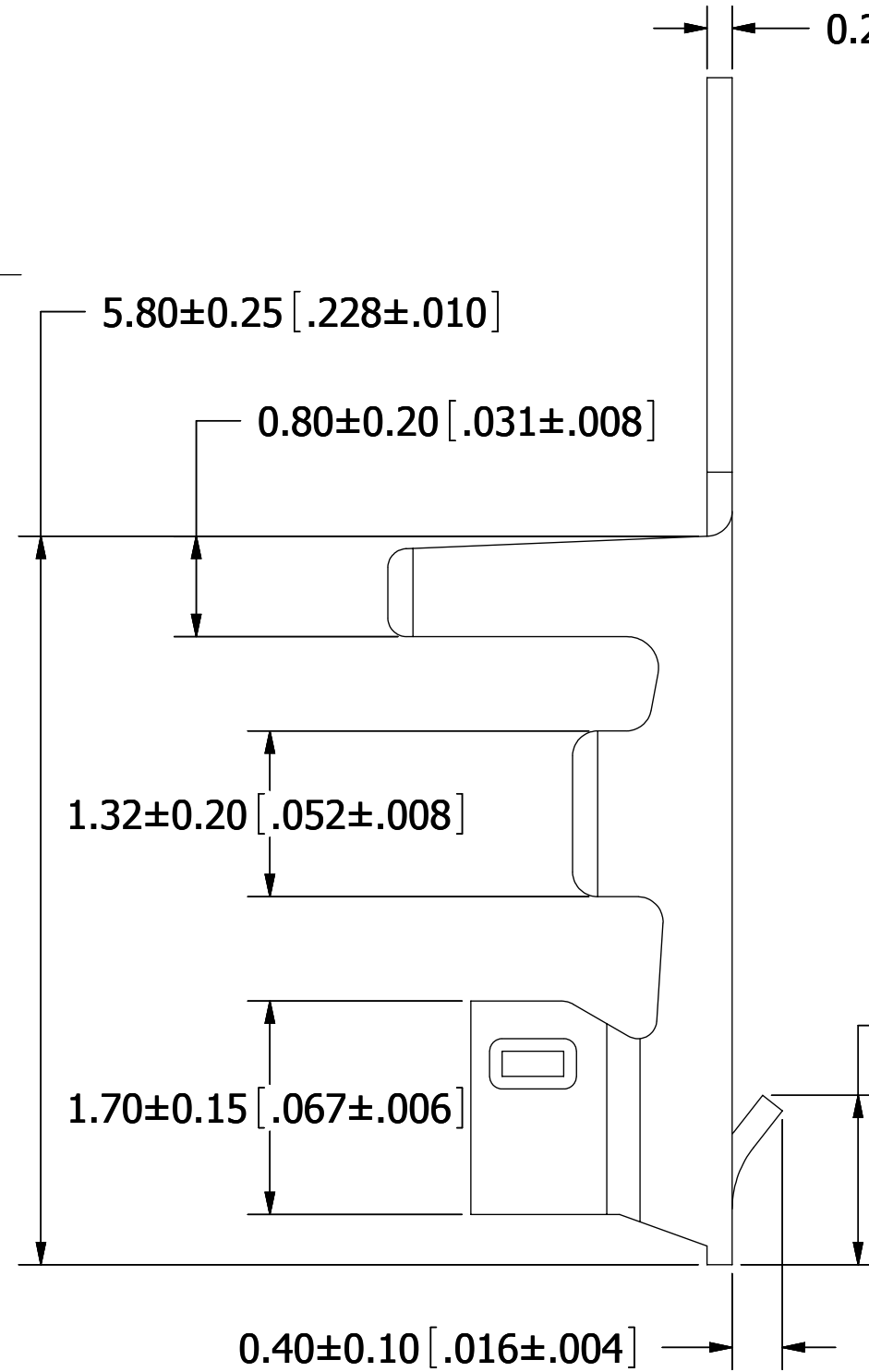
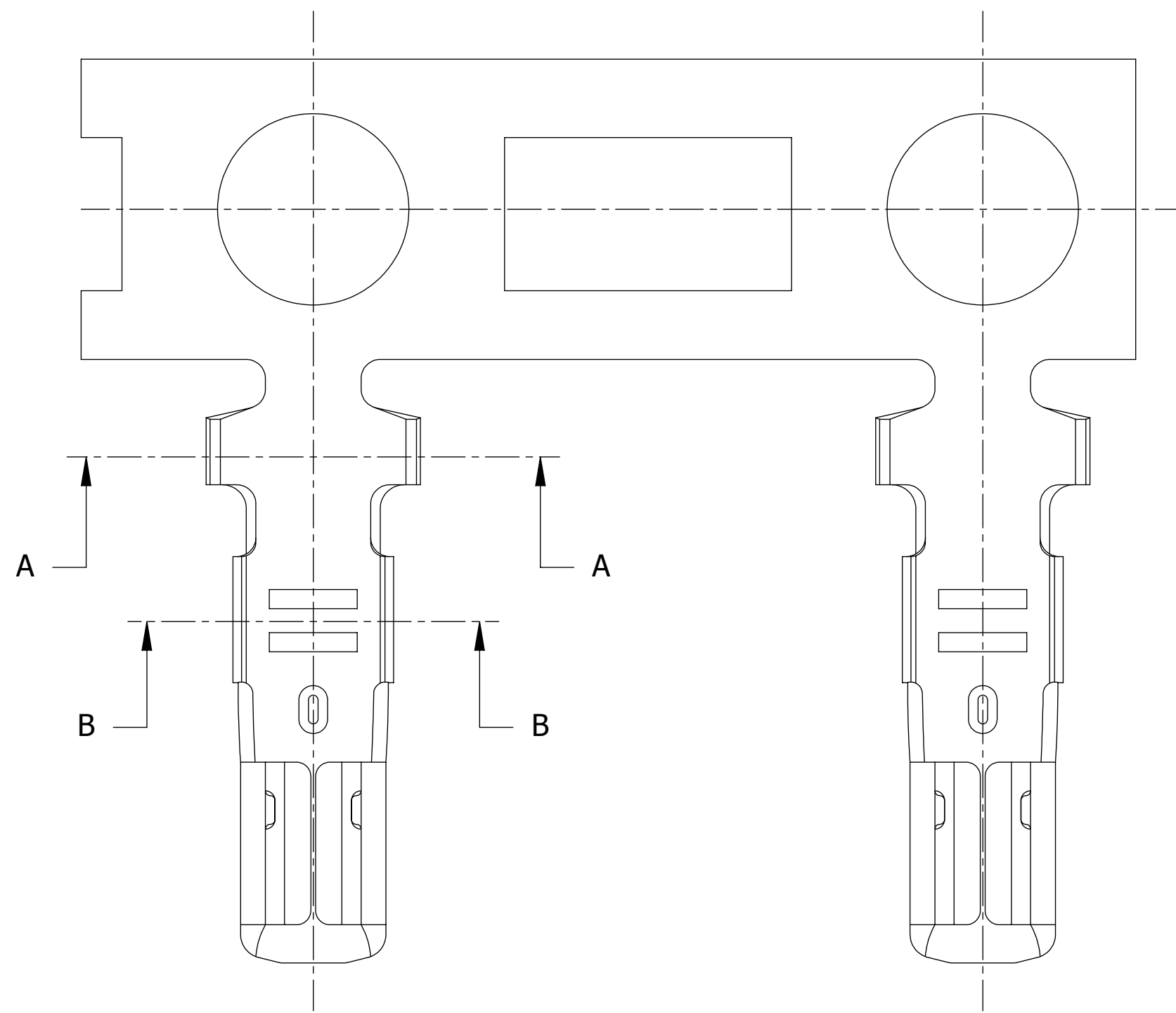

- NOTES:**
1. MATERIAL: PHOSPHOR BRONZE.
 2. PLATING: SEE PART NUMBER CODING.
 3. WIRE RANGE: AWG #24 - #30.
 4. INSULATION O.D.: 1.50mm MAX.
 5. QUANTITY PER REEL = 10,000 PIECES.
 6. USED IN SWH201 SERIES HOUSING.

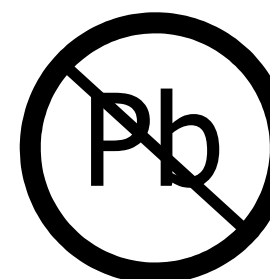

RoHS COMPLIANT

UNLESS OTHERWISE SPECIFIED:
DIMENSIONS ARE IN MM [INCHES]
TOLERANCES:
ANGULAR: ± 5°
.X = ± .3 [.01]
.XX = ± .15 [.006]
.XXX = ± .050 [.0020]
SURFACE FINISH: 63 R_a
REMOVE ALL BURRS AND SHARP EDGES .010 MAX

INTERPRET DIMENSIONS AND GEOMETRIC TOLERANCING PER: ANSI Y14.5M-1994

DATE	NAME	
9/09/09	JH	
<small>THE INFORMATION HEREIN CONTAINS PROPRIETARY INFORMATION OF SULLINS ELECTRONICS AND IS NOT TO BE REPRODUCED, USED OR DISCLOSED TO OTHERS FOR ANY PURPOSE EXCEPT AS SPECIFICALLY AUTHORIZED IN WRITING BY AN OFFICER OF SULLINS ELECTRONICS.</small>		DESCRIPTION CRIMP TERMINAL - SWH201 PART NUMBER SWT201-UP_N-S01-UU-UU
SIZE	DWG. NO.	REV
C	11296	A
SCALE: 18:1		SHEET 1 OF 1