

PRODUCT NO.	HOUSING POST
10055090-001	NO
10055090-001LF	
10055090-002	YES
10055090-002LF	

NOTE:

- MATERIALS:
HOUSING: HIGH TEMPERATURE THERMOPLASTIC, UL 94V-0 RATED, BLACK.
TERMINAL: HIGH CONDUCTIVITY COPPER ALLOY.
- PLATING SPEC:
10055090-XXX:
CONTACT AREA: 30u" GOLD OVER 50u" NICKEL UNDER PLATED.
SOLDER TAIL: 100u" TIN/LEAD OVER 50u" NICKEL UNDER PLATED.
10055090-XXXLF:
CONTACT AREA: 30u" GOLD OVER 50u" NICKEL UNDER PLATED.
SOLDER TAIL: 100u" TIN OVER 50u" NICKEL UNDER PLATED.
PART NUMBER 10055090-XXXLF MEETS EUROPEAN UNION DIRECTIVE AND OTHER COUNTRY REGULATIONS AS DESCRIBED IN GS-22-008.
THE HOUSING WILL WITHSTAND EXPOSURE TO 260°C PEAK TEMPERATURE FOR 10 SECONDS IN A WAVE SOLDER APPLICATION WITH A CIRCUIT BOARD.
- PRODUCT PERFORMANCE SPEC. PER GS-12-259.
- PACKAGE SPECIFICATION PER GS-14-937.
- THE EMPTY POSITIONS ARE 18, 19, 20, 23.
- MANUFACTURER'S NAME, P/N AND DATE CODE TO APPEAR ON THIS SURFACE AS PER GS-24-007.

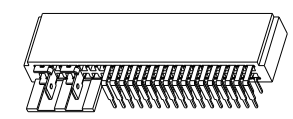
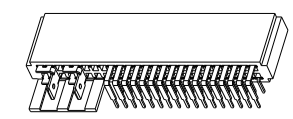
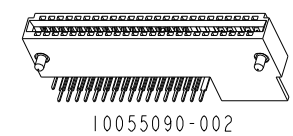
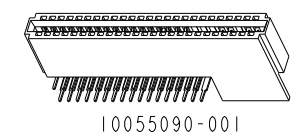
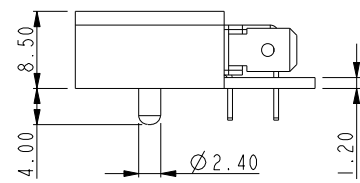
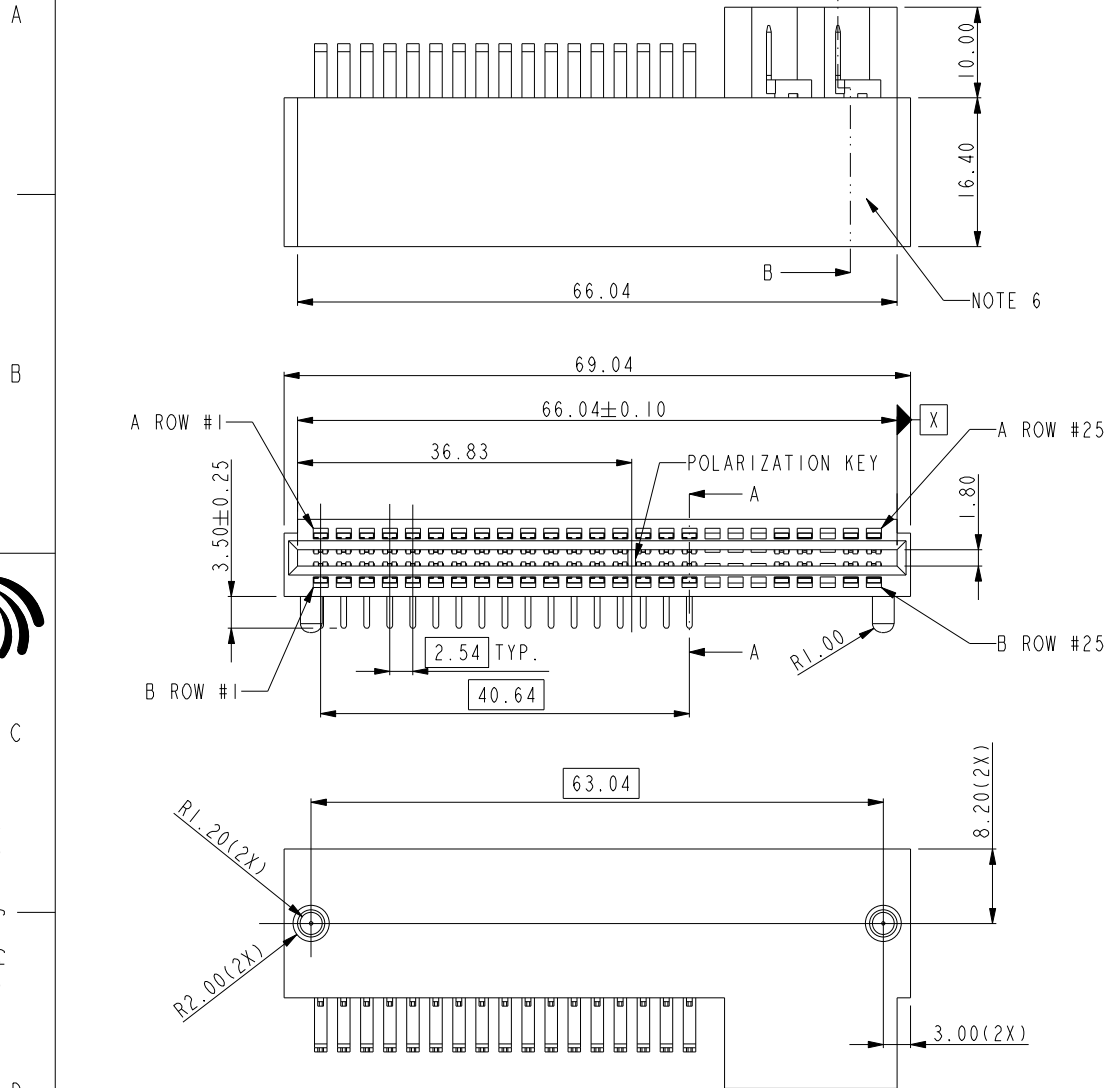

Copyright FCI.

rev	ecn no	dr	date
A	T05-0087	D T	04/22/05
B	T05-0117	D T	05/31/05
C	T05-0130	D T	06/16/05
D	T05-0162	D T	08/10/05
E	DG05-0461	SW	11/14/05
F	DG06-0306	RYAN	08/28/06
G	DG06-0524	JULIA	12/26/06

www.fciconnect.com			surface <input checked="" type="checkbox"/>	tolerance std	projection	MM
			TOLERANCES UNLESS OTHERWISE SPECIFIED			
Dr	DAVID TENG	03/30/05	ANGULAR	0.X ± .30	size	Scale
Eng	DAVID TENG	04/22/05	LINEAR	0.XX ± .15	A4	1.000
Chr	PAUL WANG	04/22/05	x" ± 2"	0.XXX ± .08	ECN	
Appr	JOSEPH HSIA	04/22/05	Product family	Spec ref #		
FCI			title		dwg no	Rev.
			POWER EDGE CARD CONNECTOR ASSY WITH LARGE CHAMFER		10055090	G
catalog			PDM: Rev:G		CUSTOMER	sheet 1 of 2

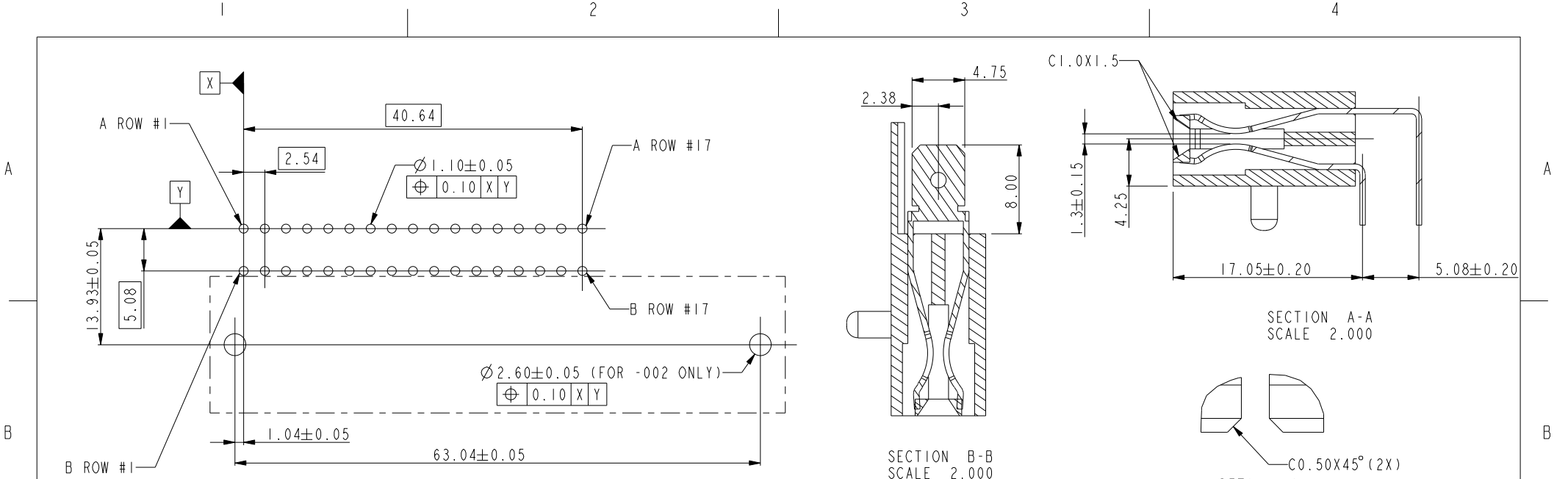

RECOMMENDED PCB LAYOUT

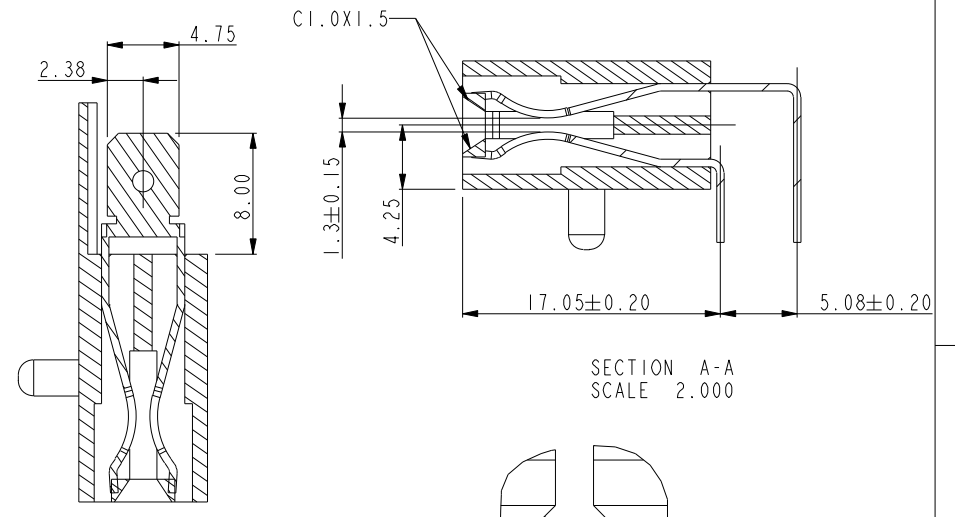

SECTION B-B
SCALE 2.000

SECTION A-A
SCALE 2.000

DETAIL A
SCALE 5.000

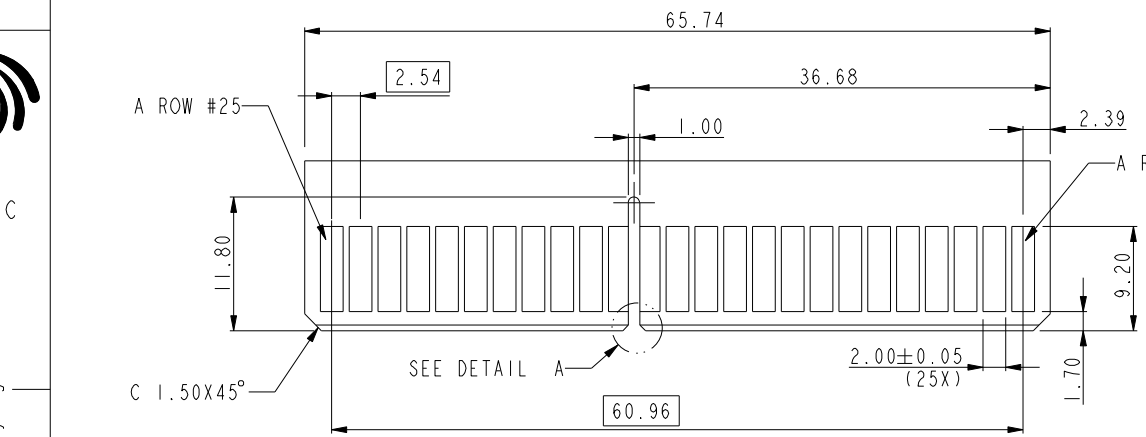

RECOMMENDED DAUGHTER CARD LAYOUT (TOP SIDE)

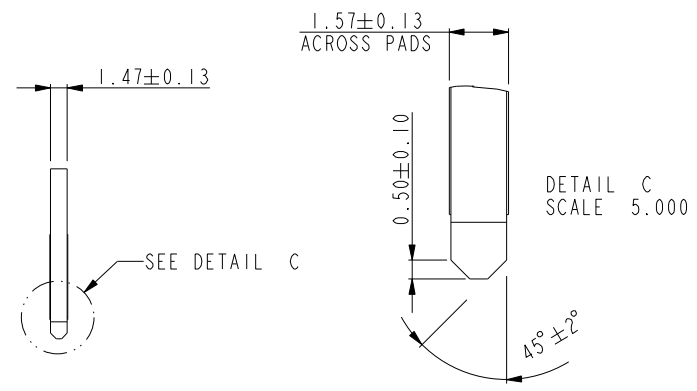

DETAIL C
SCALE 5.000

Copyright FCI.

www.fciconnect.com			surface <input checked="" type="checkbox"/>	tolerance std	projection	MM	
			TOLERANCES UNLESS OTHERWISE SPECIFIED			←→	
Dr	DAVID TENG	03/30/05	ANGULAR	0.X	±.30	size A4	Scale 1.000
Eng	DAVID TENG	04/22/05		LINEAR	0.XX		
Chr	PAUL WANG	04/22/05	X° ± 2°	0.XXX	±.08	ECN	
Appr	JOSEPH HSIA	04/22/05	Product family			Spec ref	*
FCI		title POWER EDGE CARD CONNECTOR ASSY WITH LARGE CHAMFER			dwg no 10055090		Rev. G
catalog		PDM: Rev:G			STATUS: Released		Printed: Dec 03, 2010