

## GENERAL DESCRIPTION

The 841S012DI is an optimized PCIe, sRIO and Gigabit Ethernet Frequency Synthesizer and a member of high performance clock solutions from IDT. The 841S012DI uses a 25MHz parallel resonant crystal to generate 33.33MHz - 200MHz clock signals, replacing multiple oscillators and fanout buffer solutions. The device supports  $\pm 0.25\%$  center-spread, and  $-0.5\%$  down-spread clocking with two spread select pins (SSC[1:0]). The VCO operates at a frequency of 2GHz. The device has three output banks: Bank A with two 100MHz – 250MHz HCSL outputs; Bank B with seven 33.33MHz – 200MHz LVCMOS/ LVTTTL outputs; and Bank C with one 33.33MHz – 200MHz LVCMOS/LVTTTL output.

All Banks A, B and C have their own dedicated frequency select pins and can be independently set for the frequencies mentioned above. The low jitter characteristic of the 841S012DI makes it an ideal clock source for PCIe, sRIO and Gigabit Ethernet applications. Designed for networking and industrial applications, the 841S012DI can also drive the high-speed clock inputs of communication processors, DSPs, switches and bridges.

## FEATURES

- Two 0.7V differential HCSL outputs (Bank A), configurable for PCIe (100MHz or 250MHz) and sRIO (100MHz or 125MHz) clock signals
- Eight LVCMOS/LVTTTL outputs (Banks B/C), 18 $\Omega$  typical output impedance
- Two REF\_OUT LVCMOS/LVTTTL clock outputs, 23 $\Omega$  typical output impedance
- Selectable crystal oscillator interface, 25MHz, 18pF parallel resonant crystal or one LVCMOS/LVTTTL single-ended reference clock input
- Supports the following output frequencies:  
**HCSL Bank A:** 100MHz, 125MHz, 200MHz and 250MHz  
**LVCMOS/LVTTTL Bank B/C:** 33.33MHz, 50MHz, 66.67MHz, 100MHz, 125MHz, 133.33MHz, 166.67MHz and 200MHz
- VCO: 2GHz
- Spread spectrum clock:  $\pm 0.25\%$  center-spread (typical) and  $-0.6\%$  down-spread (typical)
- PLL bypass and output enable
- RMS period jitter: 10ps (typical), QAx/nQAx outputs
- Full 3.3V supply mode
- $-40^{\circ}\text{C}$  to  $85^{\circ}\text{C}$  ambient operating temperature
- Available in lead-free (RoHS 6) package

## PIN ASSIGNMENT

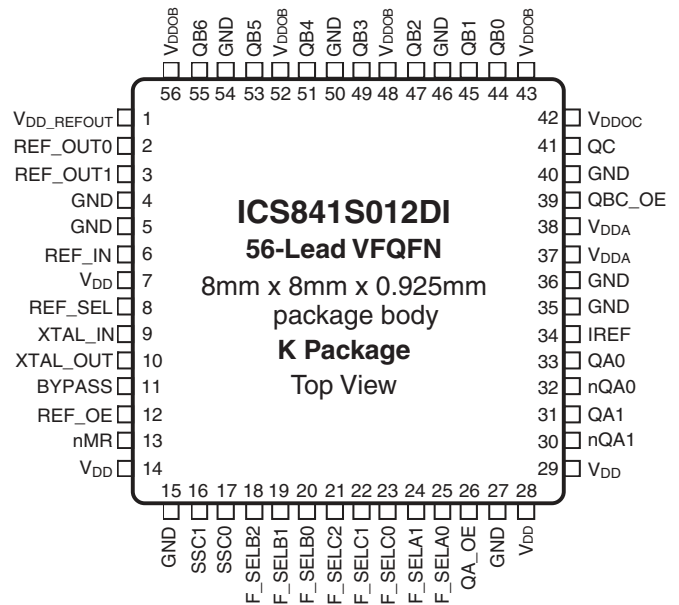

# BLOCK DIAGRAM

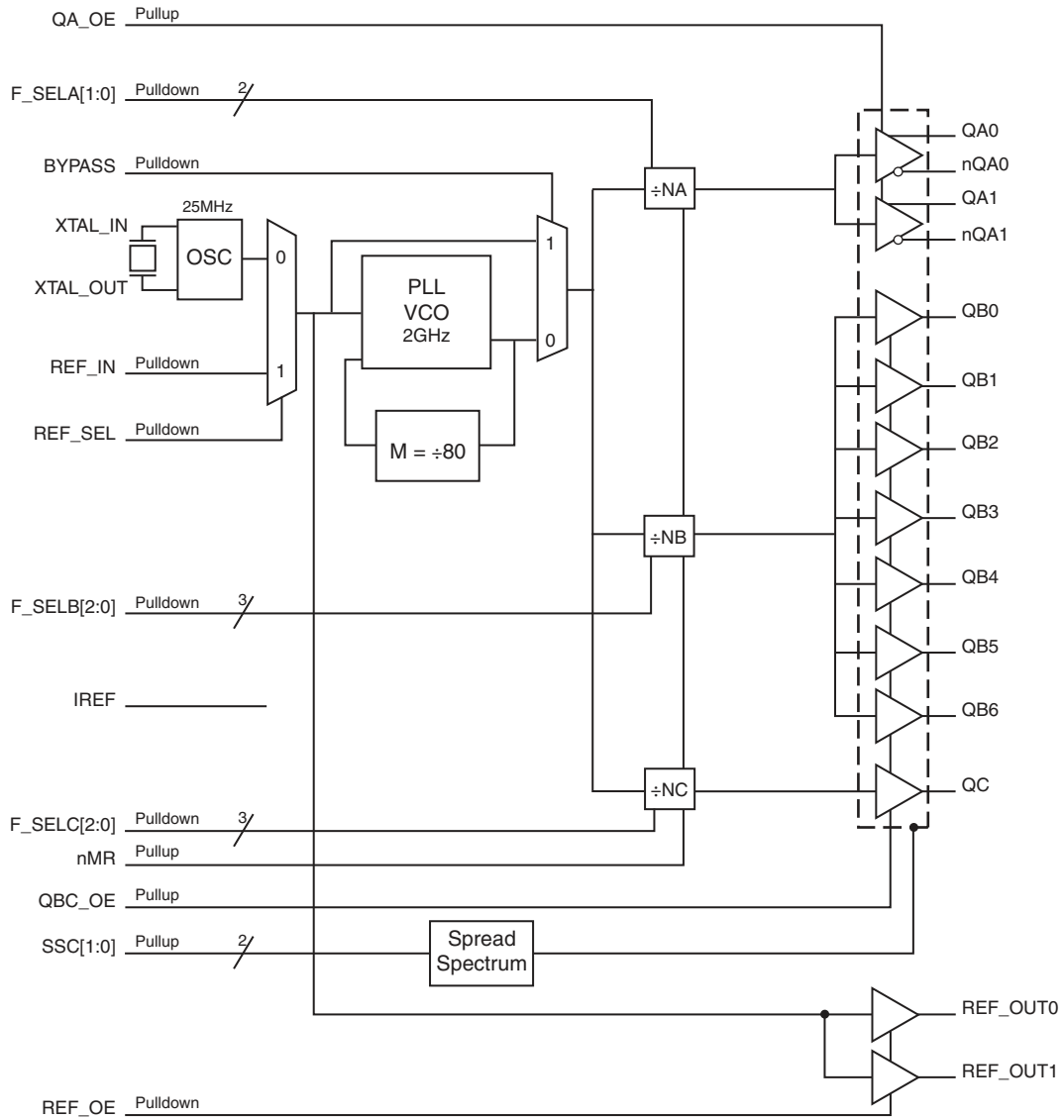

**TABLE 1. PIN DESCRIPTIONS**

Number	Name	Type		Description
1	V <sub>DD_REFOUT</sub>	Power		Output supply pin for REF_OUT.
7, 14, 28, 29	V <sub>DD</sub>	Power		Core supply pins.
2, 3	REF_OUT0, REF_OUT1	Output		Single-ended LVCMOS/LVTTL reference clock outputs. 23Ω typical output impedance.
4, 5, 15, 27, 35, 36, 40, 46, 50, 54	GND	Power		Power supply ground.
6	REF_IN	Input	Pulldown	Single-ended LVCMOS/LVTTL reference clock input.
8	REF_SEL	Input	Pulldown	Reference select pin. When HIGH selects REF_IN. When LOW, selects crystal. LVCMOS/LVTTL interface levels. See Table 3E.
9, 10	XTAL_IN, XTAL_OUT	Input		Crystal oscillator interface. XTAL_OUT is the output. XTAL_IN is the input. External tuning capacitor must be used for proper operation.
11	BYPASS	Input	Pulldown	When HIGH bypasses PLL. When LOW, selects PLL. LVCMOS/LVTTL interface levels. See Table 3J.
12	REF_OE	Input	Pulldown	Active HIGH REF_OUT enables/disables pin. LVCMOS/LVTTL interface levels. See Table 3H.
13	nMR	Input	Pullup	Active LOW Master Reset. When logic LOW, the internal dividers are reset and the outputs are in high impedance (HI-Z). When logic HIGH, the internal dividers and the outputs are enabled. LVCMOS/LVTTL interface levels. See Table 3I.
16, 17	SSC1, SSC0	Input	Pullup	SSC control pin. LVCMOS/LVTTL interface levels. See Table 3D.
18, 19, 20	F_SELB2, F_SELB1, F_SELB0	Input	Pulldown	Frequency select pins for QBx outputs. See Table 3B. LVCMOS/LVTTL interface levels.
21, 22, 23	F_SELC2, F_SELC1, F_SELC0	Input	Pulldown	Frequency select pins for QC output. See Table 3C. LVCMOS/LVTTL interface levels.
24, 25	F_SELA1, F_SELA0	Input	Pulldown	Frequency select pins for QAx/nQAx outputs. See Table 3A. LVCMOS/LVTTL interface levels.
26	QA_OE	Input	Pullup	Output enable pin for Bank A outputs. See Table 3F. LVCMOS/LVTTL interface levels.
30, 31, 32, 33	nQA1, QA1, nQA0, QA0	Output		Differential Bank A clock outputs. HCSL interface levels.
34	IREF	Output		External fixed precision resistor (475Ω) from this pin to ground provides a reference current used for differential current-mode QAx/nQAx clock outputs.
37, 38	V <sub>DDA</sub>	Power		Analog supply pin.
39	QBC_OE	Input	Pullup	Output enable pin for Bank B and Bank C outputs. LVCMOS/LVTTL Interface levels. See Table 3G.
41	QC	Output		Single-ended Bank C clock output. LVCMOS/LVTTL interface levels. 18Ω typical output impedance.
42	V <sub>DDOC</sub>	Power		Output supply pin for QC LVCMOS output.
43, 48, 52, 56	V <sub>DDOB</sub>	Power		Output supply pins for QBx LVCMOS outputs.
44, 45, 47, 49, 51, 53, 55	QB0, QB1, QB2, QB3, QB4, QB5, QB6	Output		Single-ended Bank B clock outputs. LVCMOS/LVTTL interface levels. 18Ω typical output impedance.

NOTE: Pullup and Pulldown refer to internal input resistors. See Table 2, Pin Characteristics, for typical values.

**TABLE 2. PIN CHARACTERISTICS**

Symbol	Parameter	Test Conditions	Minimum	Typical	Maximum	Units
$C_{IN}$	Input Capacitance			4		pF
$C_{PD}$	Power Dissipation Capacitance	QB[0:6], QC $V_{DD}, V_{DD\_REFOUT}, V_{DDOB}, V_{DDOC} = 3.465V$		19		pF
$R_{PULLUP}$	Input Pullup Resistor			51		k $\Omega$
$R_{PULLDOWN}$	Input Pulldown Resistor			51		k $\Omega$
$R_{OUT}$	Output Impedance	QB[0:6], QC		18		$\Omega$
		REF_OUT[1:0]		23		$\Omega$

**TABLE 3A. F\_SELA FREQUENCY SELECT FUNCTION TABLE**

Inputs				Output Frequency (25MHz Ref.)
F_SELA1	F_SELA0	M Divider Value	NA Divider Value	QA[0:1]/nQA[0:1] (MHz)
L	L	80	20	100 (default)
L	H	80	16	125
H	L	80	10	200
H	H	80	8	250

**TABLE 3B. F\_SELB FREQUENCY SELECT FUNCTION TABLE**

Inputs					Output Frequency (25MHz Ref.)
F_SELB2	F_SELB1	F_SELB0	M Divider Value	NB Divider Value	QB[0:6] (MHz)
L	L	L	80	60	33.33 (default)
L	L	H	80	40	50
L	H	L	80	30	66.67
L	H	H	80	20	100
H	L	L	80	16	125
H	L	H	80	15	133.33
H	H	L	80	12	166.67
H	H	H	80	10	200

**TABLE 3C. F\_SELc FREQUENCY SELECT FUNCTION TABLE**

Inputs					Output Frequency (25MHz Ref.)
F_SELc2	F_SELc1	F_SELc0	M Divider Value	NC Divider Value	QC (MHz)
L	L	L	80	60	33.33 (default)
L	L	H	80	40	50
L	H	L	80	30	66.67
L	H	H	80	20	100
H	L	L	80	16	125
H	L	H	80	15	133.33
H	H	L	80	12	166.67
H	H	H	80	10	200

**TABLE 3D. SSC FUNCTION TABLE**

Input		Mode
SSC1	SSC0	
0	0	0 to -0.5% Down-spread
0	1	±0.25% Center-spread
1	0	±0.25% Center-spread
1	1	SSC Off (default)

**TABLE 3E. REF\_SEL FUNCTION TABLE**

Input	
REF_SEL	Input Reference
0	XTAL
1	REF_IN

**TABLE 3F. QA\_OE FUNCTION TABLE**

Input	
QA_OE	Function
0	QA[0:1]/nQA[0:1] disabled (High-Impedance)
1 (default)	QA[0:1]/nQA[0:1] enabled

**TABLE 3G. QBC\_OE FUNCTION TABLE**

Input	
QBC_OE	Function
0	QB[0:6] and QC disabled (High-Impedance)
1 (default)	QB[0:6] and QC enabled

**TABLE 3H. REF\_OE FUNCTION TABLE**

Input	
REF_OE	Function
0 (default)	REF_OUT[0:1] disabled (High-Impedance)
1	REF_OUT[0:1] enabled

**TABLE 3I. nMR FUNCTION TABLE**

Input	
nMR	Function
0	Device reset, output divider disabled (High-Impedance)
1 (default)	Output enabled

NOTE: This device requires a reset signal after power-up to function properly.

**TABLE 3J. BYPASS FUNCTION TABLE**

Input	
BYPASS	Function
0 (default)	PLL
1	Bypass (reference ±N)

### ABSOLUTE MAXIMUM RATINGS

Supply Voltage, $V_{DD}$	4.6V
Inputs, $V_I$	-0.5V to $V_{DD} + 0.5V$
Outputs, $V_O$	-0.5V to $V_{DDO} + 0.5V$
Package Thermal Impedance, $\theta_{JA}$	31.4°C/W (0 mps)
Storage Temperature, $T_{STG}$	-65°C to 150°C

NOTE: Stresses beyond those listed under Absolute Maximum Ratings may cause permanent damage to the device. These ratings are stress specifications only. Functional operation of product at these conditions or any conditions beyond those listed in the *DC Characteristics* or *AC Characteristics* is not implied. Exposure to absolute maximum rating conditions for extended periods may affect product reliability.

**TABLE 4A. POWER SUPPLY DC CHARACTERISTICS,  $V_{DD} = V_{DD\_REFOUT} = V_{DDOB} = V_{DDOC} = 3.3V \pm 5\%$ ,  $T_A = -40^\circ C$  TO  $85^\circ C$**

Symbol	Parameter	Test Conditions	Minimum	Typical	Maximum	Units
$V_{DD}$	Core Supply Voltage		3.135	3.3	3.465	V
$V_{DDA}$	Analog Supply Voltage		$V_{DD} - 0.20$	3.3	$V_{DD}$	V
$V_{DDOB}, V_{DDOC}$	Output Supply Voltage		3.135	3.3	3.465	V
$I_{DD}$	Power Supply Current	HCSL Loaded, LVCMOS No Load			300	mA
$I_{DDA}$	Analog Supply Current				20	mA

**TABLE 4B. LVCMOS/LVTTL DC CHARACTERISTICS,  $V_{DD} = V_{DD\_REFOUT} = V_{DDOB} = V_{DDOC} = 3.3V \pm 5\%$ ,  $T_A = -40^\circ C$  TO  $85^\circ C$**

Symbol	Parameter	Test Conditions	Minimum	Typical	Maximum	Units
$V_{IH}$	Input High Voltage		2		$V_{DD} + 0.3$	V
$V_{IL}$	Input Low Voltage		-0.3		0.8	V
$I_{IH}$	Input High Current	QA_OE, QBC_OE, nMR, SSC0, SSC1, $V_{DD} = V_{IN} = 3.465V$			10	$\mu A$
		F_SELA[0:1], F_SELB[0:2], F_SELC[0:2], REF_OE, BYPASS, REF_IN, REF_SEL, $V_{DD} = V_{IN} = 3.465V$			150	$\mu A$
$I_{IL}$	Input Low Current	QA_OE, QBC_OE, nMR, SSC0, SSC1, $V_{DD} = 3.465V, V_{IN} = 0V$	-150			$\mu A$
		F_SELA[0:1], F_SELB[0:2], F_SELC[0:2], REF_OE, BYPASS, REF_IN, REF_SEL, $V_{DD} = 3.465V, V_{IN} = 0V$	-10			$\mu A$
$V_{OH}$	Output High Voltage	$V_{DDOB}, V_{DDOC} = I_{OH} = -2mA$	2.6			V
$V_{OL}$	Output Low Voltage	$V_{DDOB}, V_{DDOC} = I_{OL} = 2mA$			0.5	V

**TABLE 5. CRYSTAL CHARACTERISTICS**

Parameter	Test Conditions	Minimum	Typical	Maximum	Units
Mode of Oscillation		Fundamental			
Frequency			25		MHz
Equivalent Series Resistance (ESR)				50	$\Omega$
Shunt Capacitance				7	pF
Drive Level				100	$\mu W$

NOTE: Characterized using an 18pF parallel resonant crystal.

**TABLE 6. AC CHARACTERISTICS,  $V_{DD} = V_{DD\_REFOUT} = V_{DDOB} = V_{DDOC} = 3.3V \pm 5\%$ ,  $T_A = -40^\circ\text{C}$  TO  $85^\circ\text{C}$** 

Symbol	Parameter	Test Conditions	Minimum	Typical	Maximum	Units
$f_{OUT}$	Output Frequency	QB[0:6]	33.33		200	MHz
		QA[0:1]/nQA[0:1]	100		250	MHz
		QC	33.33		200	MHz
tsk(b)	Bank Skew; NOTE 1, 2	QB[0:6]			50	ps
		QA[0:1]/nQA[0:1]			50	ps
tsk(o)	Output Skew; NOTE 1, 3	across Banks B and C (at Same Frequency)			160	ps
tjit(cc)	Cycle-to-Cycle Jitter; NOTE 1	QA[0:1]/nQA[0:1]	All Outputs at Same Fre- quency		65	ps
tjit(per)	RMS Period Jitter	QA[0:1]/nQA[0:1]	REF_OE = 0, All Outputs at Same Frequency		10	ps
		QB[0:6]			20	ps
		QC			20	ps
$F_M$	SSC Modulation Frequency	Banks A, B, C	29		33.33	kHz
$V_{HIGH}$	Voltage High; NOTE 4, 5		580		1200	mV
$V_{LOW}$	Voltage Low; NOTE 4, 6		-150			mV
$V_{CROSS}$	Absolute Crossing Voltage; NOTE 4, 7, 8		200		600	mV
$\Delta V_{CROSS}$	Total Variation of $V_{CROSS}$ over all edges; NOTE 4, 7, 9				200	mV
$t_R / t_F$	Output Rise/Fall Time	Bank A	$\pm 150\text{mV}$ from crosspoint	25	100	ps
		Banks B, C	20% - 80%	0.4	1.3	ns
odc	Output Duty Cycle	Bank A		45	55	%
		Banks B, C		42	58	%

NOTE: Electrical parameters are guaranteed over the specified ambient operating temperature range, which is established when the device is mounted in a test socket with maintained transverse airflow greater than 500 lfpm. The device will meet specifications after thermal equilibrium has been reached under these conditions.

NOTE 1: This parameter is defined in accordance with JEDEC Standard 65.

NOTE 2: Defined as skew within a bank of outputs at the same supply voltage and with equal load conditions.

NOTE 3: Defined as skew between outputs at the same supply voltages and with equal load conditions.

Measured at  $V_{DDOB,C}/2$ .

NOTE 4: Measurement taken from single-ended waveform.

NOTE 5: Defined as the maximum instantaneous voltage including overshoot. See Parameter Measurement Information Section.

NOTE 6: Defined as the minimum instantaneous voltage including undershoot. See Parameter Measurement Information Section.

NOTE 7: Measured at crossing point where the instantaneous voltage value of the rising edge of Qx equals the falling edge of nQx. See Parameter Measurement Information Section.

NOTE 8: Refers to the total variation from the lowest crossing point to the highest, regardless of which edge is crossing. Refers to all crossing points for this measurement. See Parameter Measurement Information Section.

NOTE 9: Defined as the total variation of all crossing voltage of rising Qx and falling nQx. This is the maximum allowed variance in the  $V_{CROSS}$  for any particular system. See Parameter Measurement Information Section.

## PARAMETER MEASUREMENT INFORMATION

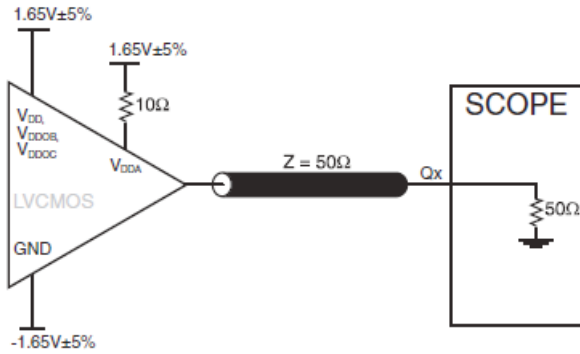

3.3V CORE/3.3V LVCMOS OUTPUT LOAD AC TEST CIRCUIT

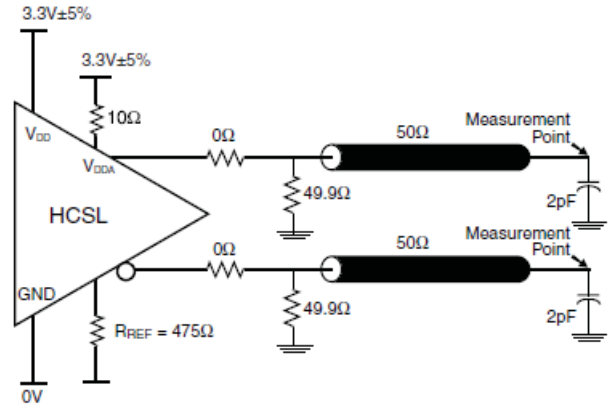

3.3V CORE/3.3V HCSL OUTPUT LOAD AC TEST CIRCUIT

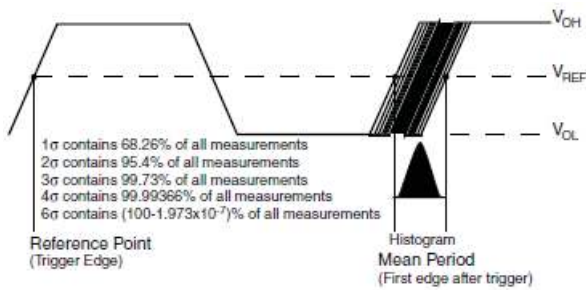

RMS PERIOD JITTER

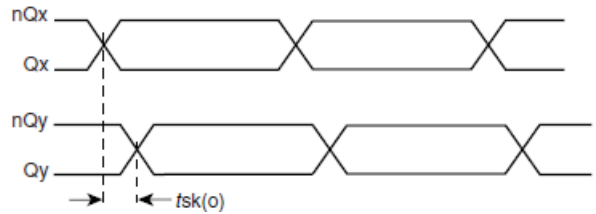

HCSL OUTPUT SKEW



LVCMOS OUTPUT SKEW

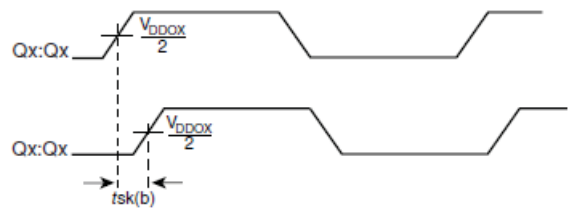

(where X = Bank B or Bank C)

LVCMOS BANK SKEW



## PARAMETER MEASUREMENT INFORMATION, CONTINUED

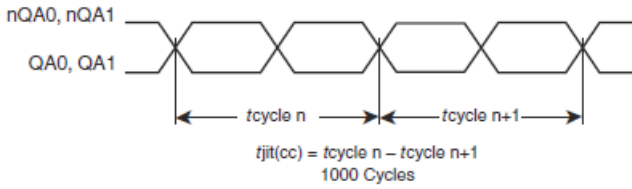

**DIFFERENTIAL CYCLE-TO-CYCLE JITTER**

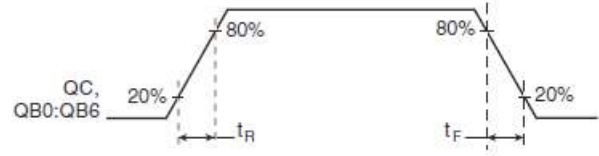

**LVCMOS RISE/FALL TIME**

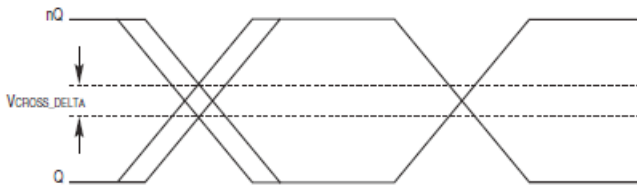

**SINGLE-ENDED MEASUREMENT POINTS FOR DELTA CROSS POINT**

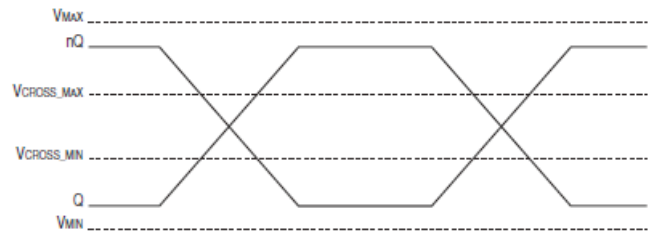

**SINGLE-ENDED MEASUREMENT POINTS FOR ABSOLUTE CROSS POINT AND SWING**

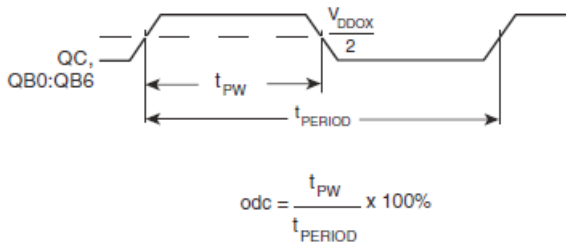

**LVCMOS OUTPUT DUTY CYCLE/PULSE WIDTH/PERIOD**

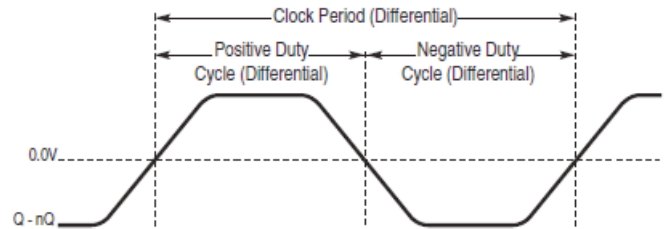

**DIFFERENTIAL MEASUREMENT POINTS FOR DUTY CYCLE/PERIOD**

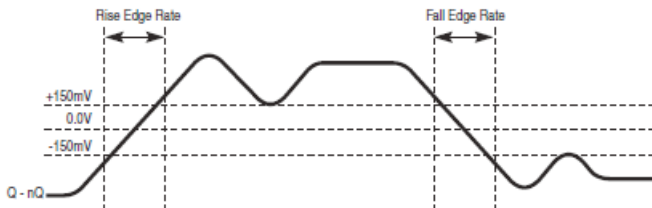

**DIFFERENTIAL MEASUREMENT POINTS FOR RISE/FALL TIME**

## APPLICATION INFORMATION

### POWER SUPPLY FILTERING TECHNIQUES

As in any high speed analog circuitry, the power supply pins are vulnerable to random noise. To achieve optimum jitter performance, power supply isolation is required. The 841S012DI provides separate power supplies to isolate any high switching noise from the outputs to the internal PLL.  $V_{DD}$ ,  $V_{DDA}$ ,  $V_{DDOB}$ , and  $V_{DDOC}$  should be individually connected to the power supply plane through vias, and  $0.01\mu\text{F}$  bypass capacitors should be used for each pin. *Figure 1* illustrates this for a generic  $V_{DD}$  pin and also shows that  $V_{DDA}$  requires that an additional  $10\Omega$  resistor along with a  $10\mu\text{F}$  bypass capacitor be connected to the  $V_{DDA}$  pin.

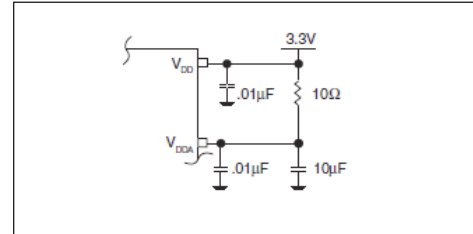

FIGURE 1. POWER SUPPLY FILTERING

### RECOMMENDATIONS FOR UNUSED INPUT AND OUTPUT PINS

#### INPUTS:

##### CRYSTAL INPUTS

For applications not requiring the use of the crystal oscillator input, both XTAL\_IN and XTAL\_OUT can be left floating. Though not required, but for additional protection, a  $1\text{k}\Omega$  resistor can be tied from XTAL\_IN to ground.

##### REF\_IN INPUT

For applications not requiring the use of the reference clock, it can be left floating. Though not required, but for additional protection, a  $1\text{k}\Omega$  resistor can be tied from the REF\_IN to ground.

##### LVC MOS CONTROL PINS

All control pins have internal pull-ups or pull-downs; additional resistance is not required but can be added for additional protection. A  $1\text{k}\Omega$  resistor can be used.

#### OUTPUTS:

##### LVC MOS OUTPUTS

All unused LVC MOS output can be left floating. We recommend that there is no trace attached.

##### DIFFERENTIAL OUTPUTS

All unused differential outputs can be left floating. We recommend that there is no trace attached. Both sides of the differential output pair should either be left floating or terminated.

### CRYSTAL INPUT INTERFACE

The 841S012DI has been characterized with 18pF parallel resonant crystals. The capacitor values shown in *Figure 2* below were determined using a 25MHz, 18pF parallel resonant crystal

and were chosen to minimize the ppm error. NOTE: External tuning capacitors must be used for proper operations.

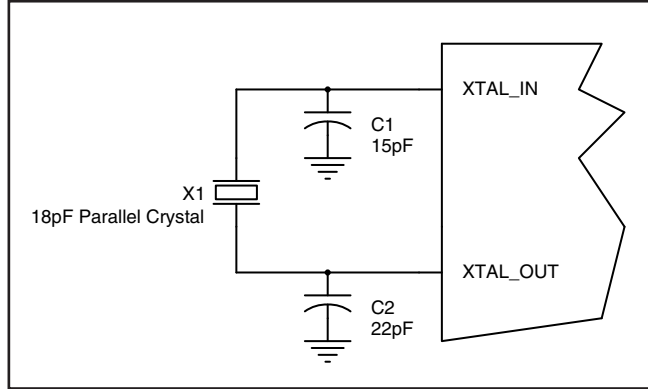

FIGURE 2. CRYSTAL INPUT INTERFACE

### LVC MOS TO XTAL INTERFACE

The XTAL\_IN input can accept a single-ended LVC MOS signal through an AC coupling capacitor. A general interface diagram is shown in *Figure 3*. The XTAL\_OUT pin can be left floating. The input edge rate can be as slow as 10ns. For LVC MOS signals, it is recommended that the amplitude be reduced from full swing to half swing in order to prevent signal interference with the power rail and to reduce noise. This configuration requires that the output impedance of the driver ( $R_o$ ) plus the series resistance ( $R_s$ ) equals

the transmission line impedance. In addition, matched termination at the crystal input will attenuate the signal in half. This can be done in one of two ways. First,  $R_1$  and  $R_2$  in parallel should equal the transmission line impedance. For most 50Ω applications,  $R_1$  and  $R_2$  can be 100Ω. This can also be accomplished by removing  $R_1$  and making  $R_2$  50Ω. By overdriving the crystal oscillator, the device will be functional, but note the device performance is guaranteed by using a quartz crystal.

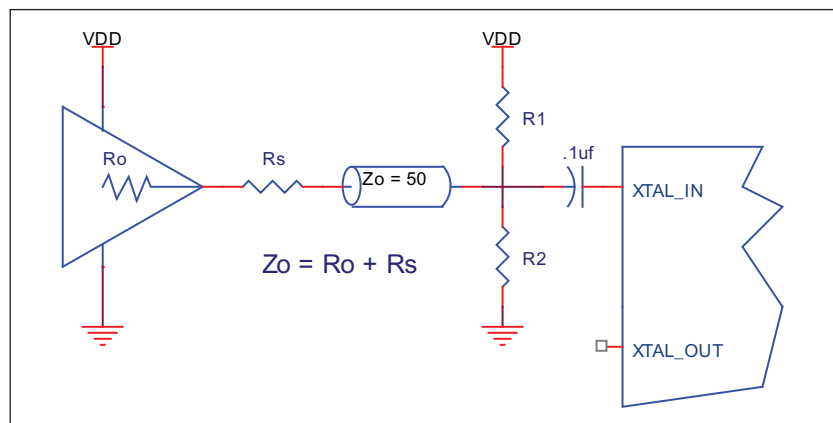

FIGURE 3. GENERAL DIAGRAM FOR LVC MOS DRIVER TO XTAL INPUT INTERFACE

**SPREAD SPECTRUM**

Spread-spectrum clocking is a frequency modulation technique for EMI reduction. When spread-spectrum is enabled, a 32kHz triangle waveform is used with 0.6% down-spread (+0.0% / -0.5%) from the nominal output frequency. An example of a triangle frequency modulation profile is shown in *Figure 4A* below. The ramp profile can be expressed as:

- F<sub>nom</sub> = Nominal Clock Frequency in Spread OFF mode
- F<sub>m</sub> = Nominal Modulation Frequency (30kHz)
- δ = Modulation Factor (0.6% down spread)

$$(1 - \delta) f_{nom} + 2 F_m \times \delta \times F_{nom} \times t \text{ when } 0 < t < \frac{1}{2F_m}$$

$$(1 - \delta) f_{nom} - 2 F_m \times \delta \times F_{nom} \times t \text{ when } \frac{1}{2F_m} < t < \frac{1}{F_m}$$

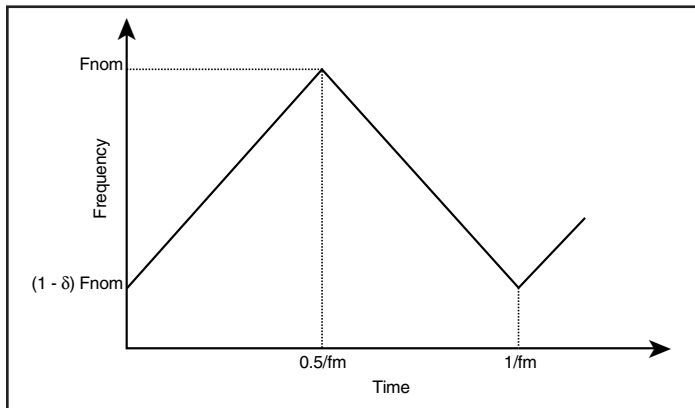

**FIGURE 4A. TRIANGLE FREQUENCY MODULATION**

The 841S012DI triangle modulation frequency deviation will not exceed 0.7% down-spread from the nominal clock frequency (+0.0% / -0.5%). An example of the amount of down spread relative to the nominal clock frequency can be seen in the frequency domain, as shown in *Figure 4B*. The ratio of this width to the fundamental frequency is typically 0.4%, and will not exceed 0.7%. The resulting spectral reduction will be greater than 5dB, as shown in *Figure 4B*. It is important to note the 841S012DI 5dB minimum spectral reduction is the component-specific EMI reduction, and will not necessarily be the same as the system EMI reduction.

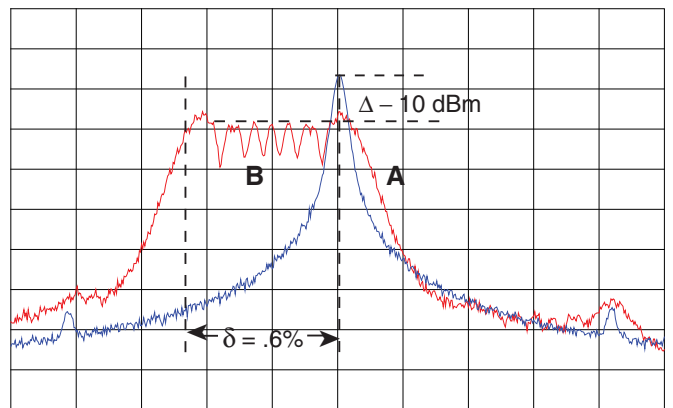

**FIGURE 4B. 200MHz CLOCK OUTPUT IN FREQUENCY DOMAIN (A) SPREAD-SPECTRUM OFF (B) SPREAD-SPECTRUM ON**

**VFQFN EPAD THERMAL RELEASE PATH**

In order to maximize both the removal of heat from the package and the electrical performance, a land pattern must be incorporated on the Printed Circuit Board (PCB) within the footprint of the package corresponding to the exposed metal pad or exposed heat slug on the package, as shown in *Figure 5*. The solderable area on the PCB, as defined by the solder mask, should be at least the same size/shape as the exposed pad/slug area on the package to maximize the thermal/electrical performance. Sufficient clearance should be designed on the PCB between the outer edges of the land pattern and the inner edges of pad pattern for the leads to avoid any shorts.

While the land pattern on the PCB provides a means of heat transfer and electrical grounding from the package to the board through a solder joint, thermal vias are necessary to effectively conduct from the surface of the PCB to the ground plane(s). The land pattern must be connected to ground through these vias. The vias act as “heat pipes”. The number of vias (i.e. “heat pipes”) are application

specific and dependent upon the package power dissipation as well as electrical conductivity requirements. Thus, thermal and electrical analysis and/or testing are recommended to determine the minimum number needed. Maximum thermal and electrical performance is achieved when an array of vias is incorporated in the land pattern. It is recommended to use as many vias connected to ground as possible. It is also recommended that the via diameter should be 12 to 13mils (0.30 to 0.33mm) with 1oz copper via barrel plating. This is desirable to avoid any solder wicking inside the via during the soldering process which may result in voids in solder between the exposed pad/slug and the thermal land. Precautions should be taken to eliminate any solder voids between the exposed heat slug and the land pattern. Note: These recommendations are to be used as a guideline only. For further information, refer to the Application Note on the *Surface Mount Assembly* of Amkor’s Thermally/Electrically Enhance Leadframe Base Package, Amkor Technology.

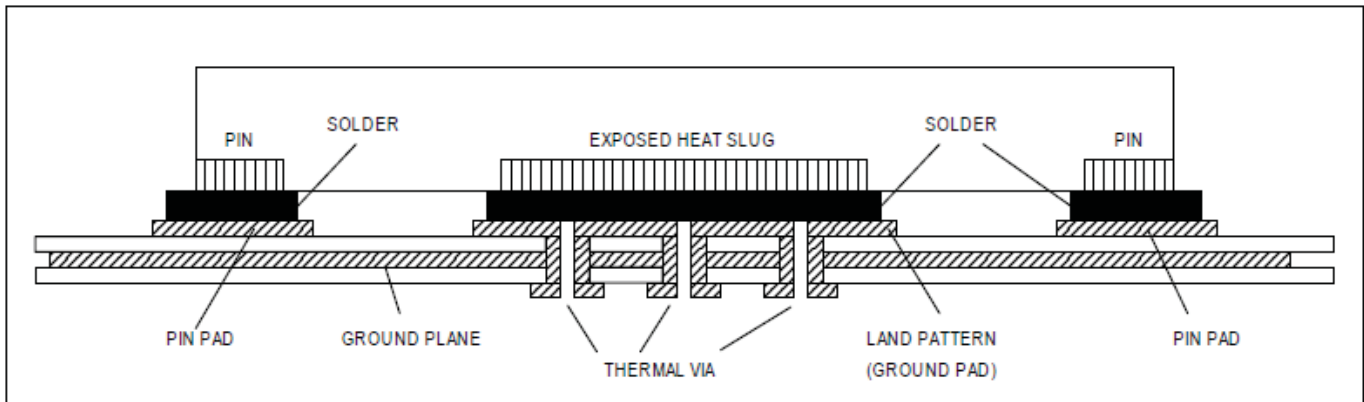

**FIGURE 5. P.C.ASSEMBLY FOR EXPOSED PAD THERMAL RELEASE PATH –SIDE VIEW (DRAWING NOT TO SCALE)**

**RECOMMENDED TERMINATION**

Figure 6A is the recommended termination for applications which require the receiver and driver to be on a separate PCB. All traces should be 50Ω impedance.

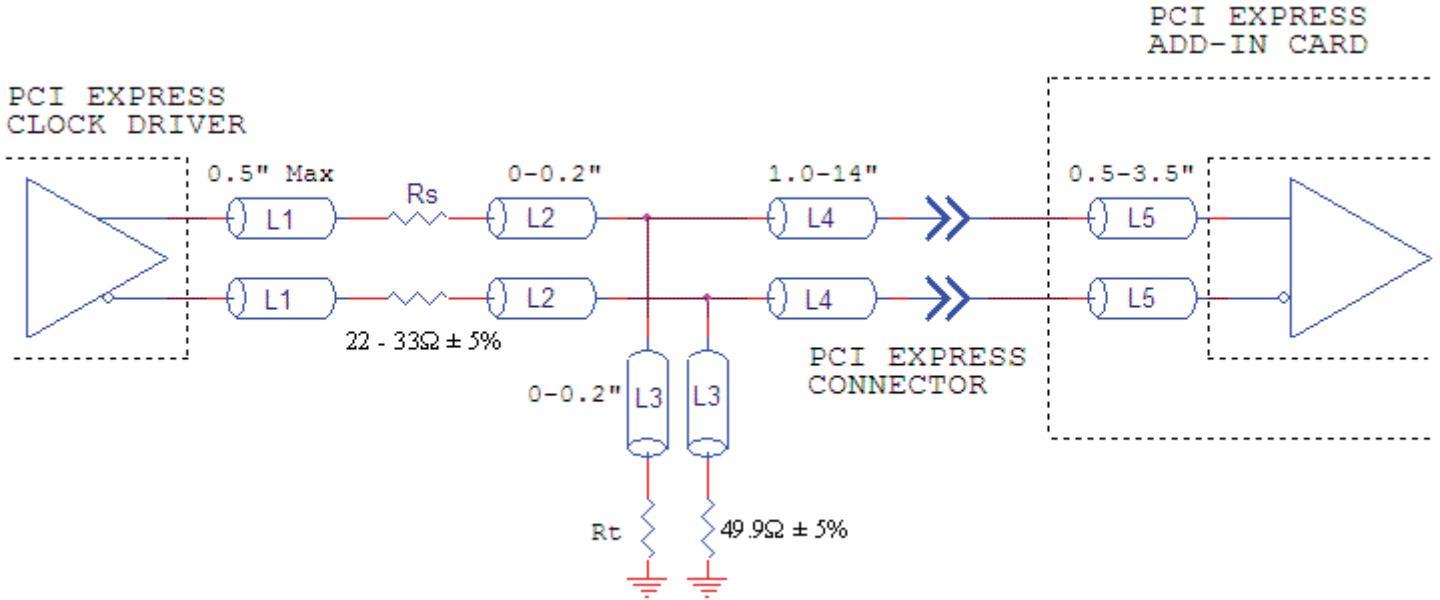

**FIGURE 6A. RECOMMENDED TERMINATION**

Figure 6B is the recommended termination for applications which require a point to point connection and contain the

driver and receiver on the same PCB. All traces should all be 50Ω impedance.

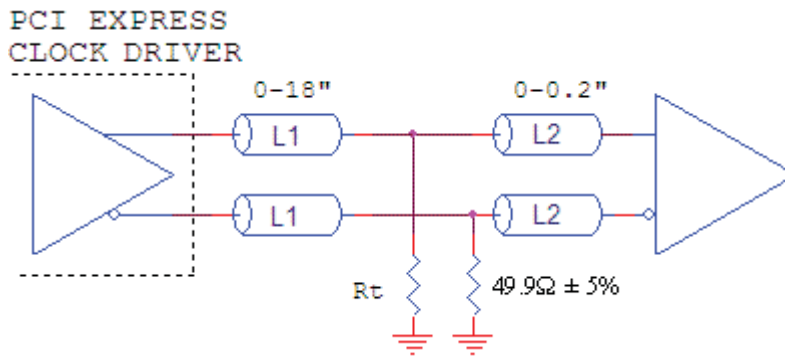
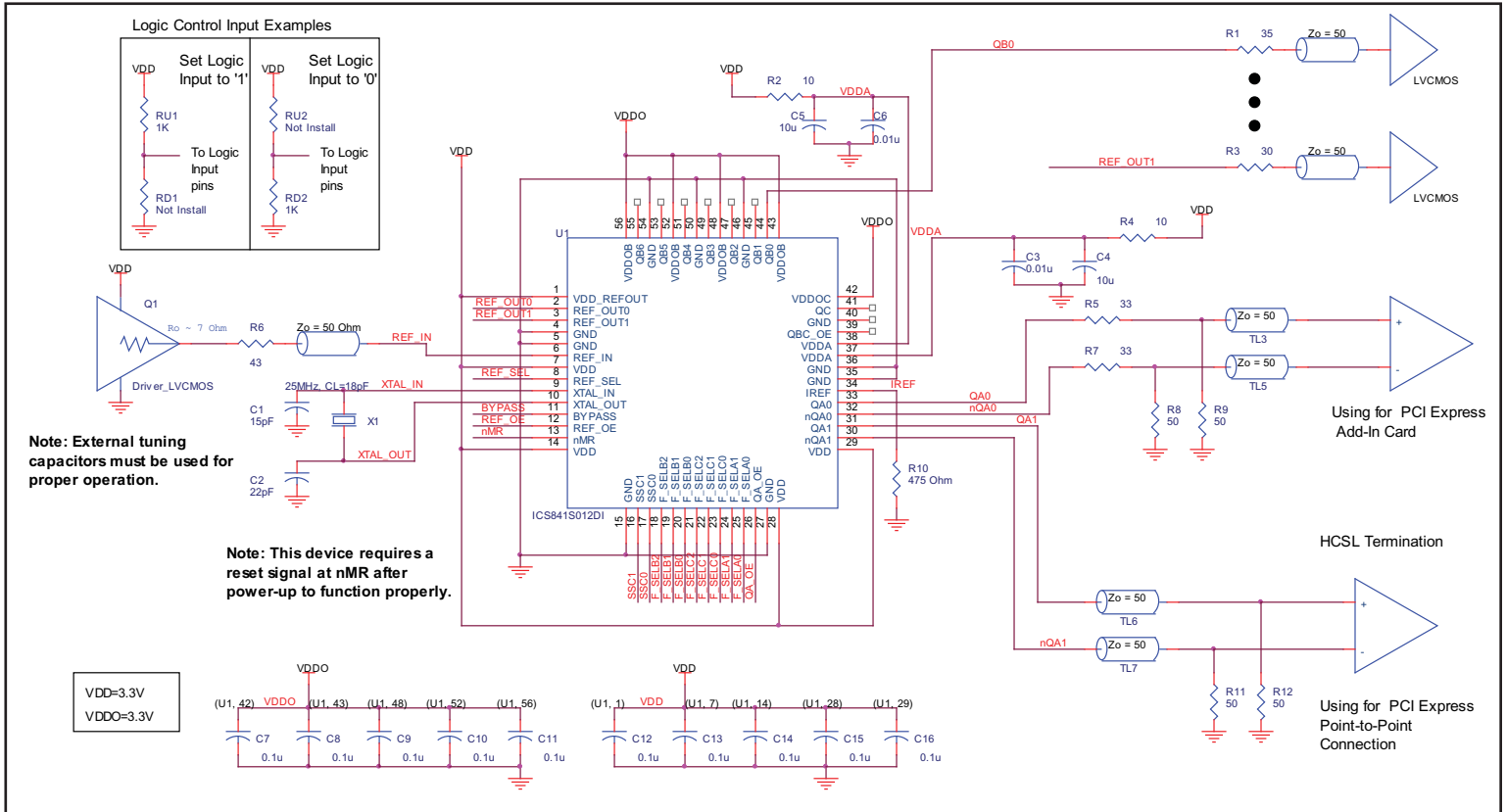

**FIGURE 6B. RECOMMENDED TERMINATION**

**SCHEMATIC EXAMPLE**

Figure 7 shows an example of the 841S012DI application schematic. In this example, the device is operated at  $V_{DD} = V_{DDOB} = V_{DDOC} = 3.3V$ . The 18pF parallel resonant 25MHz crystal is used. The  $C1 = 33pF$  and  $C2 = 33pF$  are recommended for frequency accuracy. For different board layouts, the  $C1$  and  $C2$  may be slightly adjusted

for optimizing frequency accuracy. Two examples of HCSL and one example of LVCMOS termination are shown in this schematic. The decoupling capacitors should be located as close as possible to the power pin.



**FIGURE 7. 841S012DI SCHEMATIC EXAMPLE**

## POWER CONSIDERATIONS

This section provides information on power dissipation and junction temperature for the 841S012DI. Equations and example calculations are also provided.

### 1. Power Dissipation.

The total power dissipation for the 841S012DI is the sum of the core power plus the power dissipated in the load(s). The following is the power dissipation for  $V_{DD} = 3.3V + 5\% = 3.465V$ , which gives worst case results.

#### Core and HCSL Output Power Dissipation

The maximum  $I_{DD}$  current at 85° is 284mA. The HCSL output current (17mA per output pair) is included in this value. For power considerations, this output current is treated separately from the core currents, so for power calculations,  $I_{DD} = 284mA - 2 * 17mA = 250mA$ .

- Power (core) =  $V_{DD\ MAX} * (I_{DD} + I_{DDA}) = 3.465V * (250mA + 20mA) = \mathbf{935.6mW}$   
 Power (HCSL) = **44.5mW/Load Output Pair**  
 If all outputs are loaded, the total power is  $2 * 44.5mW = \mathbf{89mW}$

#### LVCMOS Output Power Dissipation

- Dynamic Power Dissipation at 200MHz, (QB, QC)  
 Power (200MHz) =  $C_{PD} * \text{Frequency} * (V_{DDO})^2 = 19pF * 200MHz * (3.465V)^2 = \mathbf{45mW \text{ per output}}$   
**Total Power (200MHz) = 45mW \* 8 = 360mW**
- Dynamic Power Dissipation at 25MHz, (REF\_OUT)  
 Power (25MHz) =  $C_{PD} * \text{Frequency} * (V_{DDO})^2 = 19pF * 25MHz * (3.465V)^2 = \mathbf{5.6mW \text{ per output}}$   
**Total Power (25MHz) = 5.6mW \* 2 = 11.2mW**

#### Total Power Dissipation

- **Total Power**  
 = Power (core) + Power (HCSL) + Total Power (200MHz) + Total Power (25MHz)  
 = 935.6mW + 89mW + 360mW + 11mW  
 = **1396mW**



2. Junction Temperature.

Junction temperature, T<sub>j</sub>, is the temperature at the junction of the bond wire and bond pad and directly affects the reliability of the device. The maximum recommended junction temperature for HiPerClockS™ devices is 125°C.

The equation for T<sub>j</sub> is as follows:  $T_j = \theta_{JA} * Pd\_total + T_A$

T<sub>j</sub> = Junction Temperature

θ<sub>JA</sub> = Junction-to-Ambient Thermal Resistance

Pd<sub>total</sub> = Total Device Power Dissipation (example calculation is in section 1 above)

T<sub>A</sub> = Ambient Temperature

In order to calculate junction temperature, the appropriate junction-to-ambient thermal resistance θ<sub>JA</sub> must be used. Assuming 1 meter per second air flow and a multi-layer board, the appropriate value is 27.5°C/W per Table 7.

Therefore, T<sub>j</sub> for an ambient temperature of 85°C with all outputs switching is:

$$85^{\circ}\text{C} + 1.396\text{W} * 27.5^{\circ}\text{C}/\text{W} = 123.4^{\circ}\text{C}.$$

This is below the limit of 125°C.

This calculation is only an example. T<sub>j</sub> will obviously vary depending on the number of loaded outputs, supply voltage, air flow, and the type of board (multi-layer).

**TABLE 7. THERMAL RESISTANCE θ<sub>JA</sub> FOR 56 LEAD VFQFN, FORCED CONVECTION**

θ <sub>JA</sub> by Velocity (Meters per second)			
	0	1	2.5
Multi-Layer PCB, JEDEC Standard Test Boards	31.4°C/W	27.5°C/W	24.6°C/W

3. Calculations and Equations.

The purpose of this section is to calculate power dissipation on the IC per HCSL output pair.

HCSL output driver circuit and termination are shown in *Figure 8*.

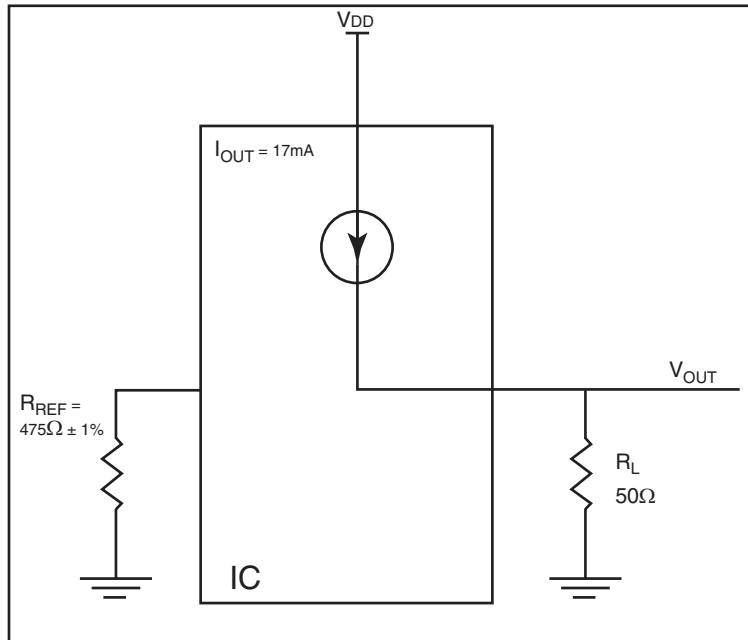

FIGURE 8. HCSL DRIVER CIRCUIT AND TERMINATION

HCSL is a current steering output which sources a maximum of 17mA of current per output. To calculate worst case on-chip power dissipation, use the following equations which assume a 50Ω load to ground.

The highest power dissipation occurs at maximum  $V_{DD}$ .

$$\text{Power} = (V_{DD\_MAX} - V_{OUT}) * I_{OUT}$$

$$\text{since } V_{OUT} = I_{OUT} * R_L$$

$$= (V_{DD\_MAX} - I_{OUT} * R_L) * I_{OUT}$$

$$= (3.465V - 17mA * 50\Omega) * 17mA$$

Total Power Dissipation per output pair = **44.5mW**

## RELIABILITY INFORMATION

TABLE 8.  $\theta_{JA}$  VS. AIR FLOW TABLE FOR 56 LEAD VFQFN

$\theta_{JA}$ by Velocity (Meters per second)			
	0	1	2.5
Multi-Layer PCB, JEDEC Standard Test Boards	31.4°C/W	27.5°C/W	24.6°C/W

### TRANSISTOR COUNT

The transistor count for 841S012DI is: 11,537

PACKAGE OUTLINE - K SUFFIX FOR 56 LEAD VFQFN

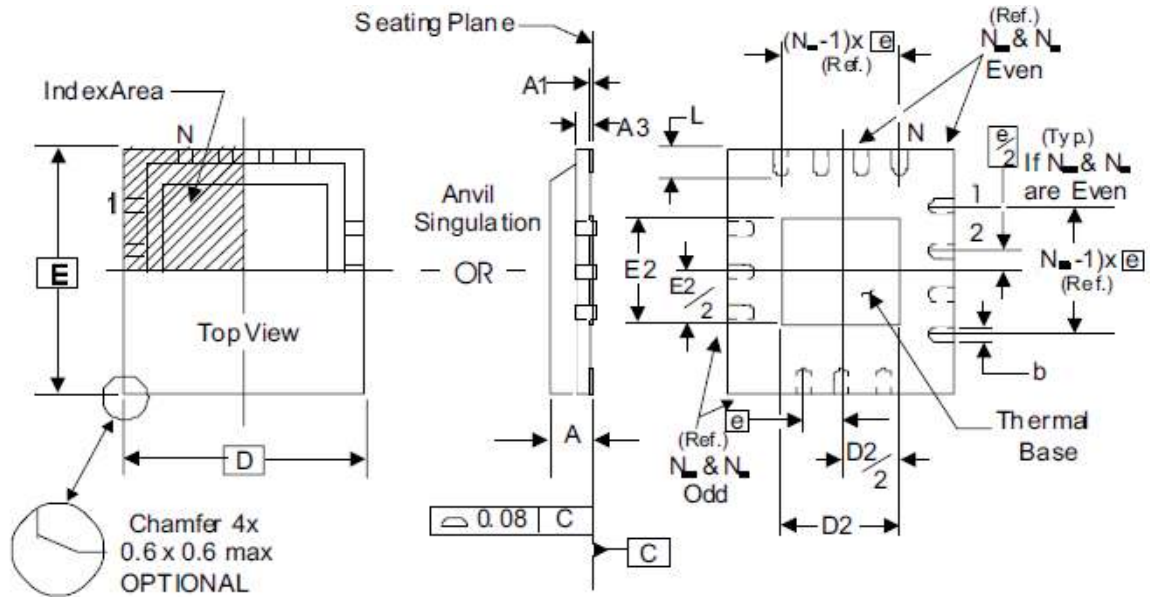

NOTE: The following package mechanical drawing is a generic drawing that applies to any pin count VFQFN package. This drawing is not intended to convey the actual pin count or pin layout of this

device. The pin count and pinout are shown on the front page. The package dimensions are in Table 9 below.

TABLE 9. PACKAGE DIMENSIONS

JEDEC VARIATION ALL DIMENSIONS IN MILLIMETERS		
SYMBOL	MINIMUM	MAXIMUM
N	56	
A	0.80	1.0
A1	0	0.05
A3	0.25 Reference	
b	0.18	0.30
e	0.50 BASIC	
N <sub>D</sub>	14	
N <sub>E</sub>	14	
D	8.0	
D2	4.35	4.65
E	8.0	
E2	5.05	5.35
L	0.3	0.55

Reference Document: JEDEC Publication 95, MO-220

**TABLE 10. ORDERING INFORMATION**

<b>Part/Order Number</b>	<b>Marking</b>	<b>Package</b>	<b>Shipping Packaging</b>	<b>Temperature</b>
841S012DKILF	ICS841S012DIL	56 lead "Lead-Free" VFQFN	tray	-40°C to 85°C
841S012DKILFT	ICS841S012DIL	56 lead "Lead-Free" VFQFN	tape & reel	-40°C to 85°C

**REVISION HISTORY SHEET**

<b>Rev</b>	<b>Table</b>	<b>Page</b>	<b>Description of Change</b>	<b>Date</b>
A		1	Removed ICS chip and Hiperlocks from the General Description. Removed ICS from the part number. Updated data sheet header and footer.	1/4/16



## IMPORTANT NOTICE AND DISCLAIMER

RENESAS ELECTRONICS CORPORATION AND ITS SUBSIDIARIES (“RENESAS”) PROVIDES TECHNICAL SPECIFICATIONS AND RELIABILITY DATA (INCLUDING DATASHEETS), DESIGN RESOURCES (INCLUDING REFERENCE DESIGNS), APPLICATION OR OTHER DESIGN ADVICE, WEB TOOLS, SAFETY INFORMATION, AND OTHER RESOURCES “AS IS” AND WITH ALL FAULTS, AND DISCLAIMS ALL WARRANTIES, EXPRESS OR IMPLIED, INCLUDING, WITHOUT LIMITATION, ANY IMPLIED WARRANTIES OF MERCHANTABILITY, FITNESS FOR A PARTICULAR PURPOSE, OR NON-INFRINGEMENT OF THIRD PARTY INTELLECTUAL PROPERTY RIGHTS.

These resources are intended for developers skilled in the art designing with Renesas products. You are solely responsible for (1) selecting the appropriate products for your application, (2) designing, validating, and testing your application, and (3) ensuring your application meets applicable standards, and any other safety, security, or other requirements. These resources are subject to change without notice. Renesas grants you permission to use these resources only for development of an application that uses Renesas products. Other reproduction or use of these resources is strictly prohibited. No license is granted to any other Renesas intellectual property or to any third party intellectual property. Renesas disclaims responsibility for, and you will fully indemnify Renesas and its representatives against, any claims, damages, costs, losses, or liabilities arising out of your use of these resources. Renesas' products are provided only subject to Renesas' Terms and Conditions of Sale or other applicable terms agreed to in writing. No use of any Renesas resources expands or otherwise alters any applicable warranties or warranty disclaimers for these products.

(Disclaimer Rev.1.0 Mar 2020)

### Corporate Headquarters

TOYOSU FORESIA, 3-2-24 Toyosu,  
Koto-ku, Tokyo 135-0061, Japan  
[www.renesas.com](http://www.renesas.com)

### Contact Information

For further information on a product, technology, the most up-to-date version of a document, or your nearest sales office, please visit:  
[www.renesas.com/contact/](http://www.renesas.com/contact/)

### Trademarks

Renesas and the Renesas logo are trademarks of Renesas Electronics Corporation. All trademarks and registered trademarks are the property of their respective owners.