

HF/VHF/UHF RF power N-channel MOSFETs

Datasheet - production data

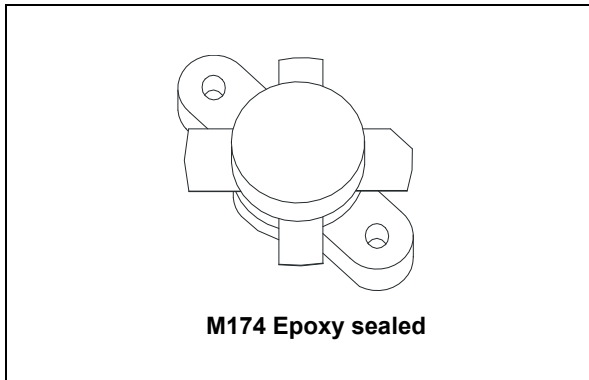
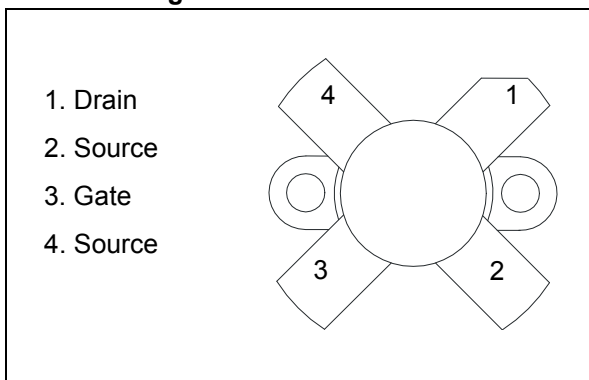

Figure 1. Pin connection



Features

- Gold metallization
- Excellent thermal stability
- Common source configuration
- $P_{OUT} = 175$ W min. with 15 dB gain @ 175 MHz, 50 V
- $P_{OUT} = 135$ W typ. with 14 dB gain @ 123 MHz, 28 V
- Low $R_{DS(on)}$
- Thermally enhanced packaging for lower junction temperatures
- In compliance with the 2002/95/EC1 European directive

Description

The SD2941-10 is a gold metallized N-channel MOS field-effect RF power transistor, intended for use in 28 V to 50 V dc large signal applications up to 230 MHz. It offers 25% lower $R_{DS(on)}$ than the industry standard, with 20% higher P_{SAT} than ST's SD2931-10 device. The SD2941-10 is housed in the low thermal M174 non-pedestal package, offering 25% lower thermal resistance than the industry standard, thus rendering it the "best-in-class" transistor for ISM applications, where reliability and ruggedness are critical factor.

Table 1. Device summary

Order code	Marking	Base qty.	Package	Packaging ⁽¹⁾
SD2941-10W	SD2941-10 ⁽¹⁾	25 pcs	M174	Plastic tray

1. For more details please refer to [Chapter 7: Marking, packing and shipping specifications](#).

Contents

1	Electrical data	3
	1.1 Maximum rating	3
2	Electrical characteristics	4
3	Impedance	6
4	Typical performance	7
5	Test circuit	10
6	Package information	13
7	Marking, packing and shipping specifications	15
8	Revision history	16

1 Electrical data

1.1 Maximum rating

($T_{CASE} = 25\text{ °C}$)

Table 2. Absolute maximum rating

Symbol	Parameter	Value	Unit
$V_{(BR)DSS}^{(1)}$	Drain source voltage	130	V
$V_{DGR}^{(1)}$	Drain-gate voltage ($R_{GS} = 1M\Omega$)	130	V
V_{GS}	Gate-source voltage	± 40	V
I_D	Drain current	20	A
P_{DISS}	Power dissipation	389	W
T_J	Max. operating junction temperature	200	$^{\circ}C$
T_{STG}	Storage temperature	-65 to +150	$^{\circ}C$

1. $T_J = 150\text{ °C}$

Table 3. Thermal data

Symbol	Parameter	Value	Unit
R_{thJC}	Junction to case thermal resistance	0.45	$^{\circ}C/W$

2 Electrical characteristics

($T_{CASE} = 25\text{ }^{\circ}\text{C}$)

Table 4. Static

Symbol	Test conditions		Min.	Typ.	Max.	Unit
$V_{(BR)DSS}^{(1)}$	$V_{GS} = 0\text{ V}$	$I_{DS} = 100\text{ mA}$	130			V
I_{DSS}	$V_{GS} = 0\text{ V}$	$V_{DS} = 50\text{ V}$			50	mA
I_{GSS}	$V_{GS} = 20\text{ V}$	$V_{DS} = 0\text{ V}$			250	nA
$V_{GS(Q)}^{(2)}$	$V_{DS} = 10\text{ V}$	$I_D = 250\text{ mA}$				V
$V_{DS(ON)}$	$V_{GS} = 10\text{ V}$	$I_D = 10\text{ A}$			2.0	V
G_{FS}	$V_{DS} = 10\text{ V}$	$I_D = 5\text{ A}$	5	6		mho
C_{ISS}	$V_{GS} = 0\text{ V}$	$V_{DS} = 50\text{ V}$		415		pF
C_{OSS}	$V_{GS} = 0\text{ V}$	$V_{DS} = 50\text{ V}$		236		pF
$CRSS$	$V_{GS} = 0\text{ V}$	$V_{DS} = 50\text{ V}$		17		pF

1. $T_J = 150^{\circ}\text{C}$
2. $V_{GS(Q)}$ sorted with alpha/numeric code marked on unit.

Table 5. Dynamic

Symbol	Test conditions		Min.	Typ.	Max.	Unit
P_{OUT}	$V_{DD} = 28\text{ V}$ $I_{DQ} = 250\text{ mA}$ $f = 123\text{ MHz}$			135		W
	$V_{DD} = 50\text{ V}$ $I_{DQ} = 250\text{ mA}$ $f = 175\text{ MHz}$		175	200		
G_{PS}	$V_{DD} = 28\text{ V}$ $I_{DQ} = 250\text{ mA}$ $P_{OUT} = 135\text{ W}$ $f = 123\text{ MHz}$			14		dB
	$V_{DD} = 50\text{ V}$ $I_{DQ} = 250\text{ mA}$ $P_{OUT} = 175\text{ W}$ $f = 175\text{ MHz}$		14	15.8		
h_D	$V_{DD} = 28\text{ V}$ $I_{DQ} = 250\text{ mA}$ $P_{OUT} = 135\text{ W}$ $f = 123\text{ MHz}$			65		%
	$V_{DD} = 50\text{ V}$ $I_{DQ} = 250\text{ mA}$ $P_{OUT} = 175\text{ W}$ $f = 175\text{ MHz}$		55	65		
Load Mismatch	$V_{DD} = 50\text{ V}$ $I_{DQ} = 250\text{ mA}$ $P_{OUT} = 175\text{ W}$ $f = 175\text{ MHz}$ All phase angles		10:1			VSWR
	$V_{DD} = 28\text{ V}$ $I_{DQ} = 250\text{ mA}$ $P_{OUT} = 135\text{ W}$ $f = 123\text{ MHz}$ All phase angles		25:1			

Table 6. V_{GS} sorts

Symbol	Value	Symbol	Value	Symbol	Value
AA	1.5 - 1.6	E	2.4 - 2.5	P	3.3 - 3.4
BB	1.6 - 1.7	F	2.5 - 2.6	Q	3.4 - 3.5
CC	1.7 - 1.8	G	2.6 - 2.7	R	3.5 - 3.6
DD	1.8 - 1.9	H	2.7 - 2.8	S	3.6 - 3.7
EE	1.9 - 2.0	J	2.8 - 2.9	T	3.7 - 3.8
A	2.0 - 2.1	K	2.9 - 3.0	U	3.8 - 3.9
B	2.1 - 2.2	L	3.0 - 3.1	V	3.9 - 4.0
C	2.2 - 2.3	M	3.1 - 3.2		
D	2.3 - 2.4	N	3.2 - 3.3		

3 Impedance

Figure 2. Impedance data schematic

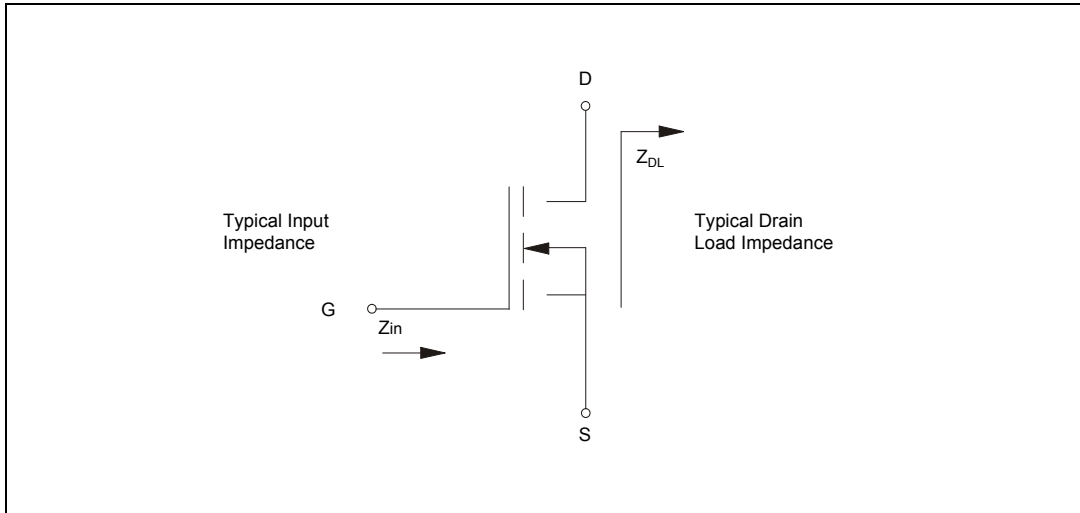

Table 7. Impedance data @ 28 V

f	Z_{IN} (Ω)	Z_{DL} (100W) (Ω)	Z_{DL} (140W) (Ω)
123 MHz	$1.2 - j 3.3$	$2.0 + j 1.4$	$2.0 + j 0.73$

Table 8. Impedance data @ 50 V

f	Z_{IN} (Ω)	Z_{DL} (Ω)
30 MHz	$1.7 - j 5.7$	$6.8 + j 0.9$
175 MHz	$1.2 - j 2.0$	$2.0 + j 2.4$

4 Typical performance

Figure 3. Capacitance vs drain voltage

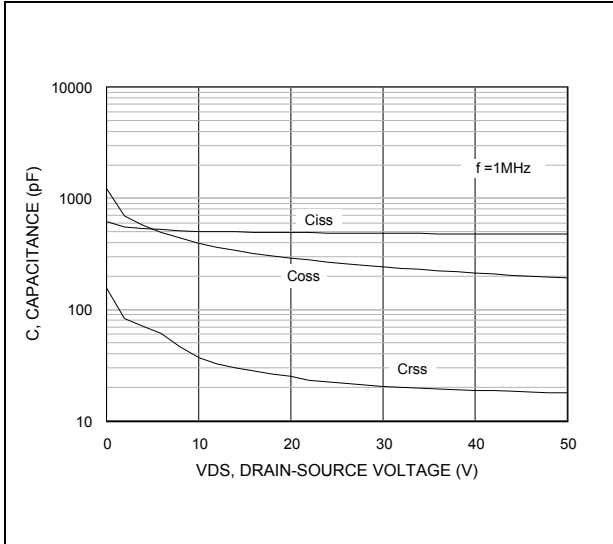

Figure 4. Drain current vs gate voltage

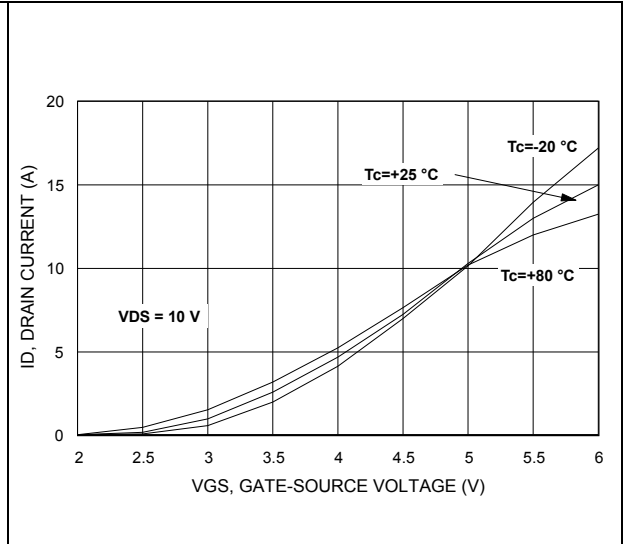

Figure 5. Maximum thermal resistance vs case temperature

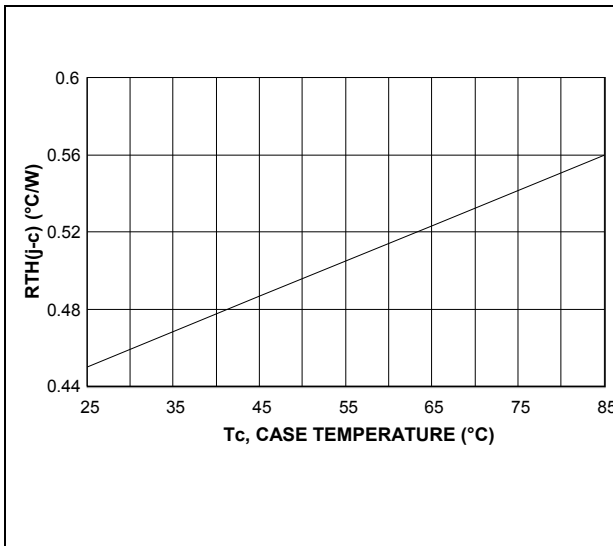

Figure 6. Safe operating area

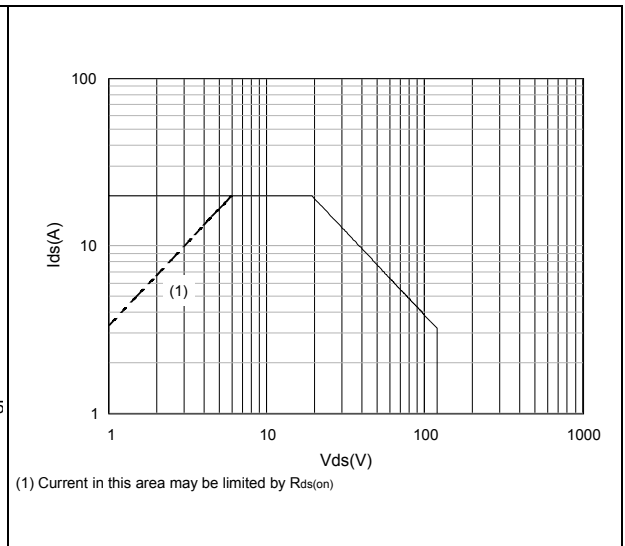

Figure 7. Power gain vs output power

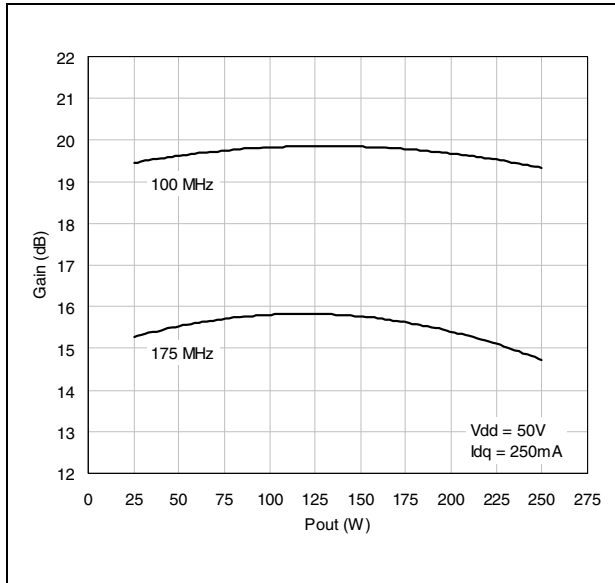

Figure 8. Efficiency vs output power

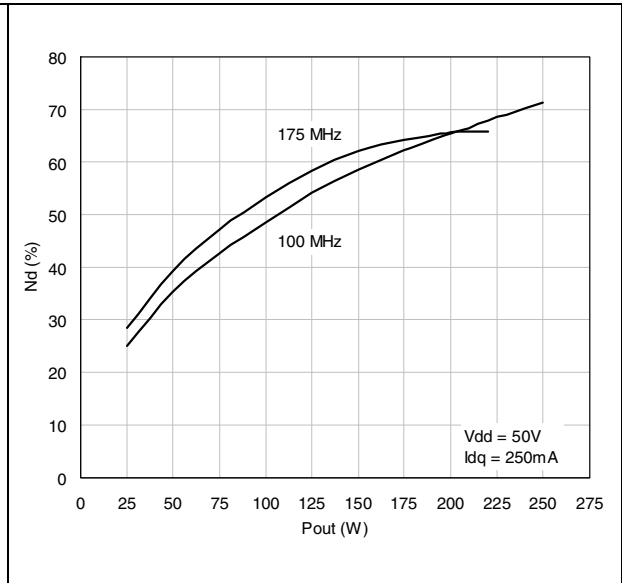

Figure 9. Input return loss vs output power

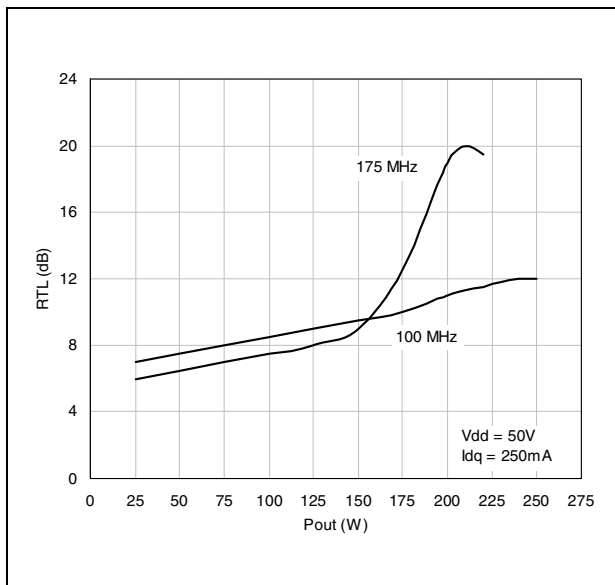

Figure 10. Gain and efficiency vs output power @ 28V and 100W load line

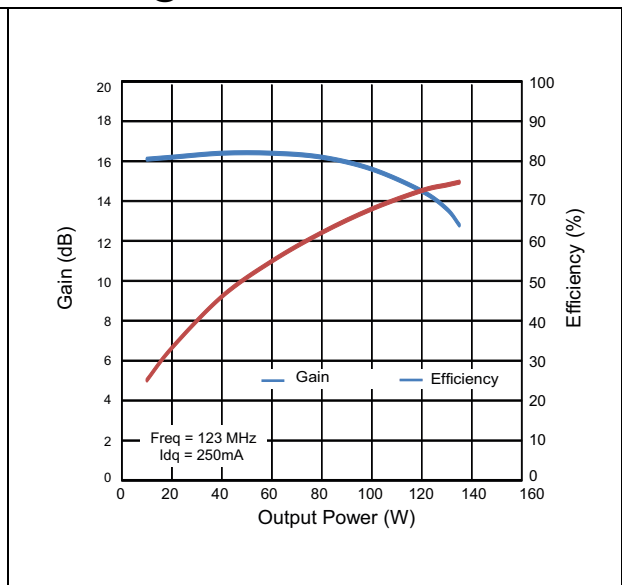
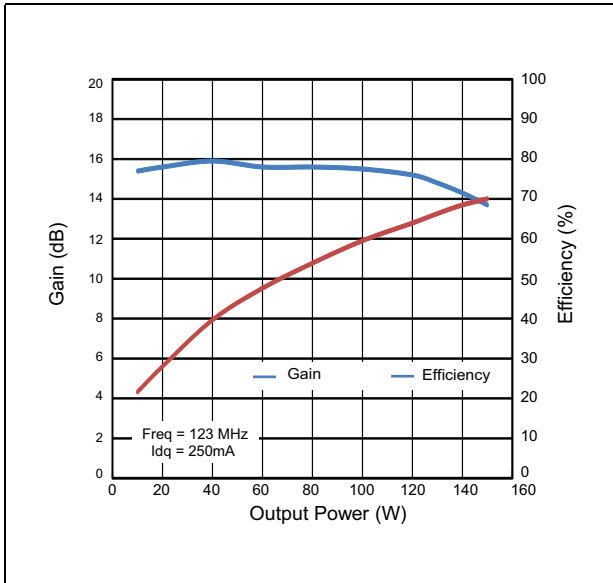
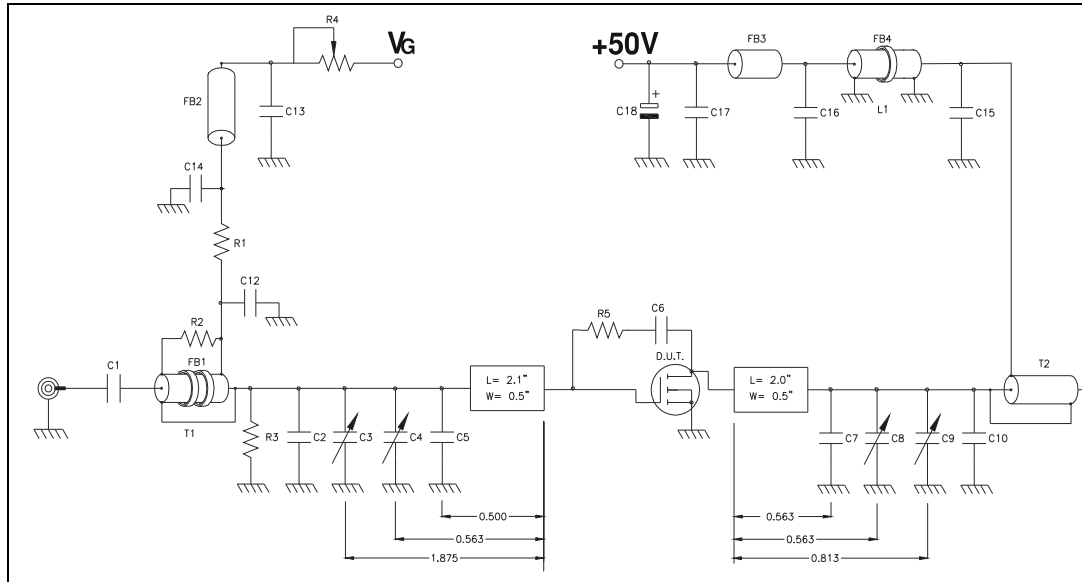

Figure 11. Gain and efficiency vs output power @ 28V and 140W load line



5 Test circuit

Figure 12. 30 MHz test circuit schematic (engineering test circuit)



Note: All dimension are in inches.

Table 9. 30 MHz test circuit component part list

Symbol	Description
T2	1:4 transformer, 25 Ω semi-rigid coax.141 OD 6" Long
FB1	Toroid X 2, 0.5" OD.312" ID 850μ 2 turns
FB2, FB3	VK200
FB4	Shield bead, 1" OD 0.5" ID 850μ 3 Turns
L1	1/4 Wave Choke, 50W Semi-rigid coax.141 OD 12" Long
PCB	0.62" woven fiberglass, 1 oz. copper, 2 sides, εr = 2.55
R1, R3	470 Ω 1 W chip resistor
R2	360 Ω 1/2 W resistor
R4	20 KΩ 10 turn potentiometer
R5	560 Ω 1 W resistor
C1, C11	470 pF ATC chip cap
C2	43 pF ATC chip cap
C3, C8, C9	Arco 404, 12-65 pF
C4	Arco 423, 16-100 pF
C5	120 pF ATC chip cap
C6	0.01 μF ATC chip cap
C7	30 pF ATC chip cap

Table 9. 30 MHz test circuit component part list (continued)

Symbol	Description
C10	91 pF ATC chip cap
C12, C15	1200 pF ATC chip cap
C13, C14,C16, C17	0.01 mF / 500 V chip cap
C18	10 mF 63 V electrolytic capacitor

Figure 13. 175 MHz test circuit photomaster

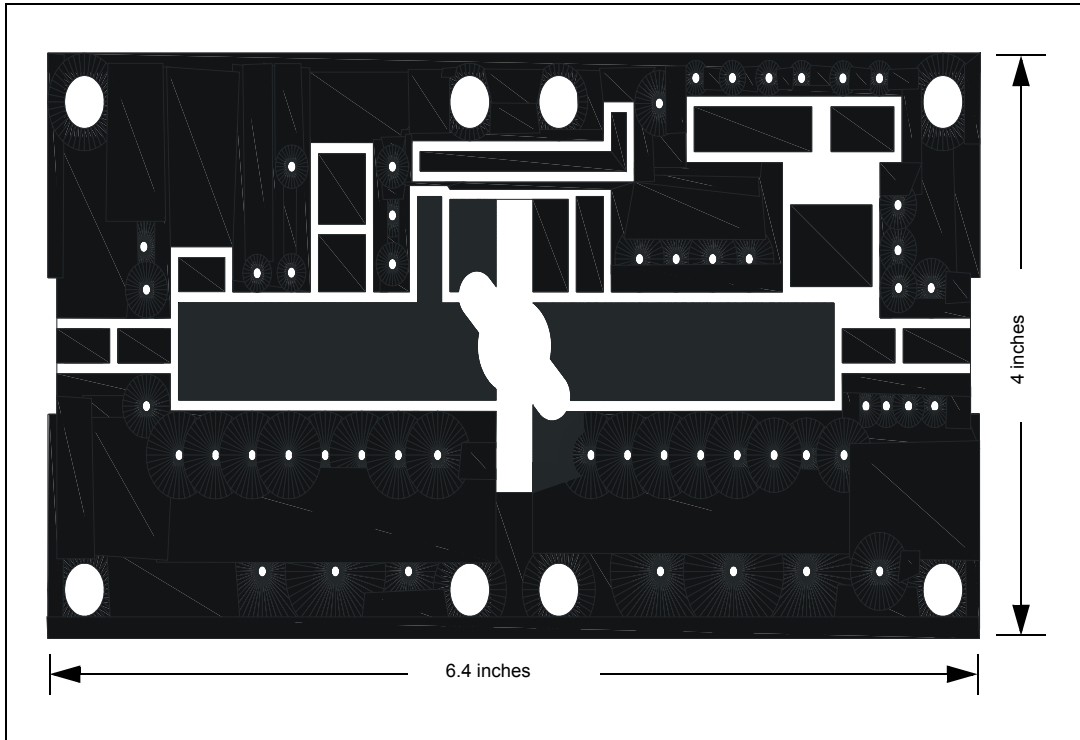
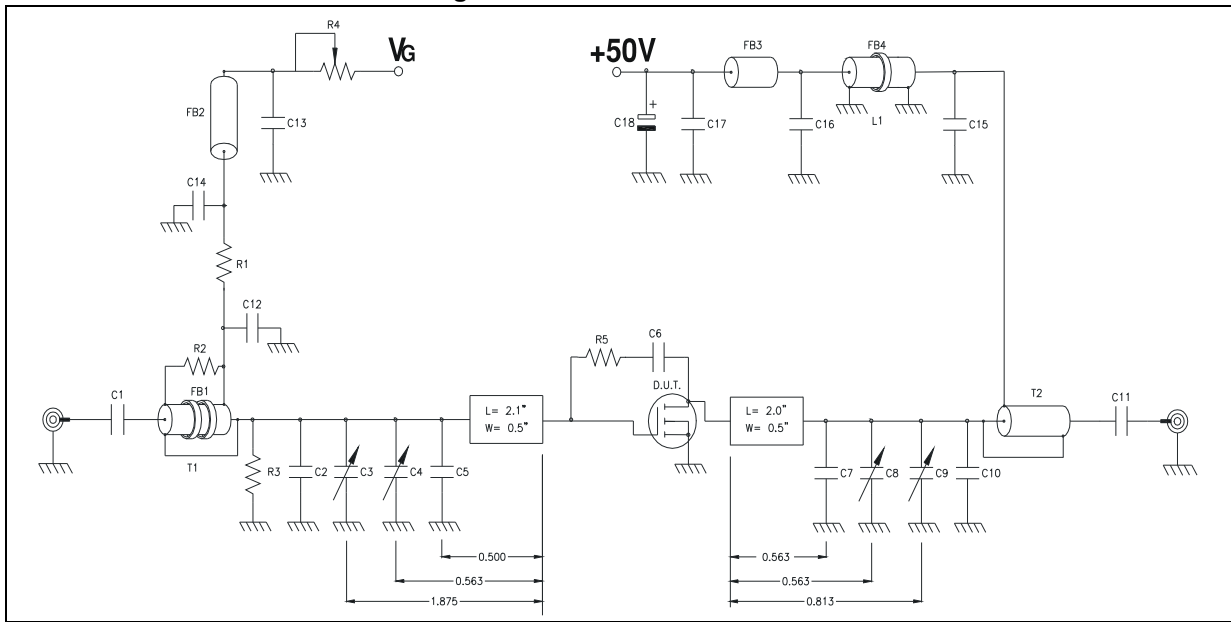

Figure 14. 175 MHz test circuit



6 Package information

In order to meet environmental requirements, ST offers these devices in different grades of ECOPACK[®] packages, depending on their level of environmental compliance. ECOPACK[®] specifications, grade definitions and product status are available at: www.st.com. ECOPACK[®] is an ST trademark.

Figure 15. M174 package dimensions

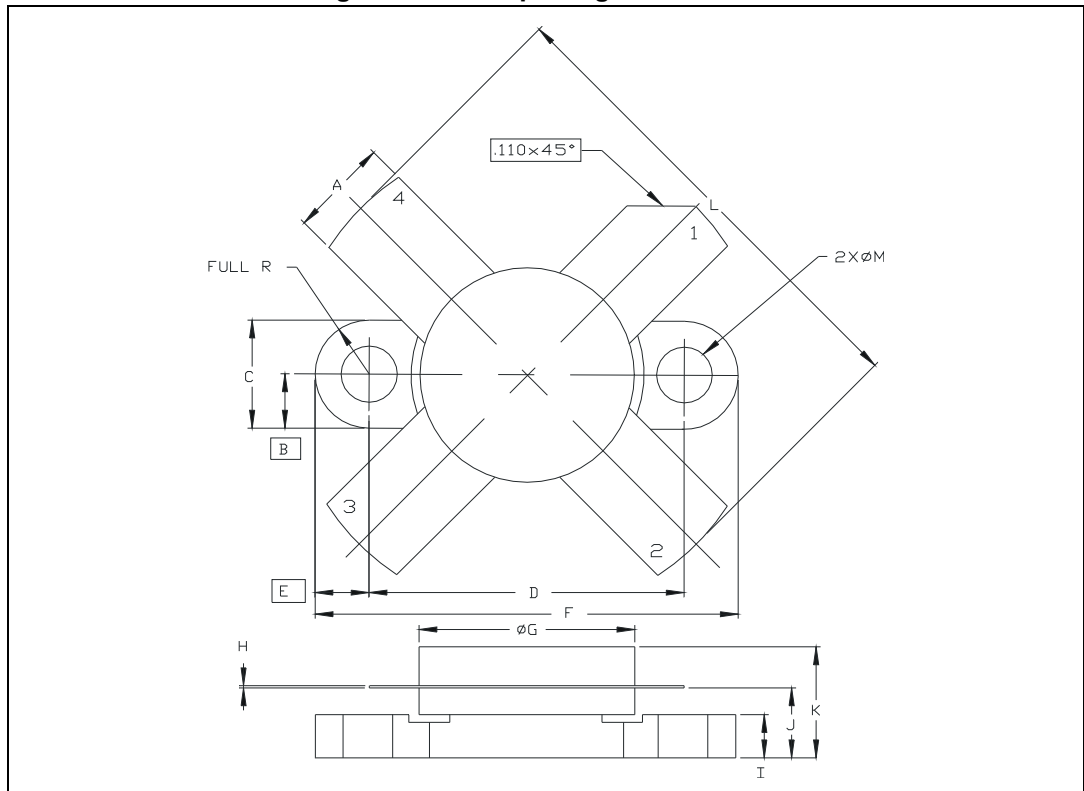

Table 10. M174 (.500 DIA 4/L N/HERM W/FLG)

DIM.	mm.			inch		
	min.	typ.	max	min.	typ.	max
A	5.56		5.584	0.219		0.230
B		3.18			0.125	
C	6.22		6.48	0.245		0.255
D	18.28		18.54	0.720		0.730
E		3.18			0.125	
F	24.64		24.89	0.970		0.980
G	12.57		12.83	0.495		0.505
H	0.08		0.18	0.003		0.007
I	2.11		3.00	0.083		0.118
J	3.81		4.45	0.150		0.175
K			7.11			0.280
L	25.53		26.67	1.005		1.050
M	3.05		3.30	0.120		0.130

7 Marking, packing and shipping specifications

Table 11. Packing and shipping specifications

Order code	Packaging	Pcs per tray	Dry pack humidity	V _{GS} code	Lot code
SD2941-10W	Plastic tray	25	< 10%	Not mixed	Not mixed

Figure 16. Marking layout

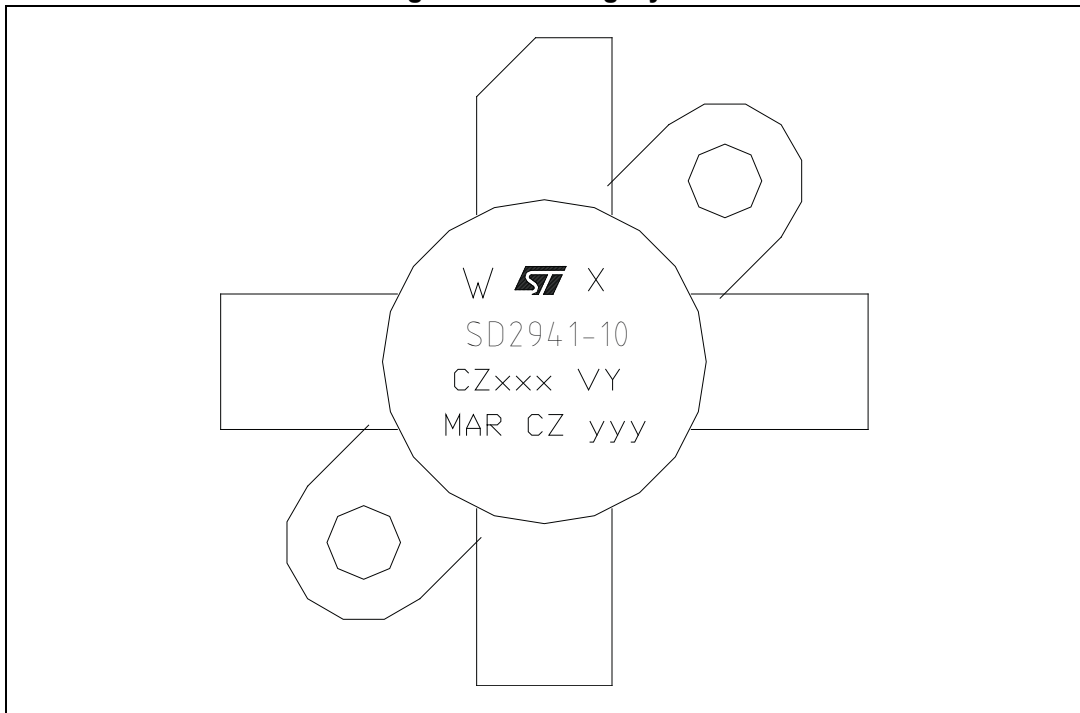

Table 12. Marking specifications

Symbol	Description
W	Wafer process code
X	V _{GS} sort
CZ	Assembly plant
xxx	Last 3 digit of diffusion lot
VY	Diffusion plant
MAR	Country of origin
CZ	Test and finishing plant
y	Assembly year
yy	Assembly week

8 Revision history

Table 13. Document revision history

Date	Revision	Changes
15-Nov-2005	1	Initial release
06-Apr-2006	2	Complete version
13-Apr-2006	3	V _{DS(ON)} updated
19-Oct-2011	4	Inserted Section 7: Marking, packing and shipping specifications . Minor text changes in the title and description on the coverpage.
04-Aug-2014	5	Added performances at 28 V.
14-Aug-2015	6	Updated Table 2.: Absolute maximum rating . Minor text changes.

IMPORTANT NOTICE – PLEASE READ CAREFULLY

STMicroelectronics NV and its subsidiaries (“ST”) reserve the right to make changes, corrections, enhancements, modifications, and improvements to ST products and/or to this document at any time without notice. Purchasers should obtain the latest relevant information on ST products before placing orders. ST products are sold pursuant to ST’s terms and conditions of sale in place at the time of order acknowledgement.

Purchasers are solely responsible for the choice, selection, and use of ST products and ST assumes no liability for application assistance or the design of Purchasers’ products.

No license, express or implied, to any intellectual property right is granted by ST herein.

Resale of ST products with provisions different from the information set forth herein shall void any warranty granted by ST for such product.

ST and the ST logo are trademarks of ST. All other product or service names are the property of their respective owners.

Information in this document supersedes and replaces information previously supplied in any prior versions of this document.

© 2015 STMicroelectronics – All rights reserved