

3V, Dual Trip Point Temperature Sensor

Features:

- Integrated Temp Sensor and Detector Operate from a Supply Voltage as Low as 2.7V
- Replaces Mechanical Thermostats and Switches
- On-Chip Temperature Sense
- 8-Pin DIP or SOIC for Direct PCB Mounting
- 2 User Programmable Temperature Set Points
- 2 Independent Temperature Limit Outputs
- Heat/Cool Regulate Output

Applications:

- CPU Thermal Management
- System Over or Under Temperature Shutdown
- Advanced Thermal Warning
- Fan Speed Control Circuits
- Accurate Appliance Temperature Sensing
- Environmental Control

Device Selection Table

| Part Number | Package | Temp. Range |
|-------------|------------|-----------------|
| TC623CCOA | 8-Pin SOIC | 0°C to +70°C |
| TC623CCPA | 8-Pin PDIP | 0°C to +70°C |
| TC623CEOA | 8-Pin SOIC | -40°C to +85°C |
| TC623CEPA | 8-Pin PDIP | -40°C to +85°C |
| TC623CVOA | 8-Pin SOIC | -40°C to +125°C |

Note: Latch Output (C option), is a Standard Device Contact Factory for Latch Q Output (H option).

Functional Block Diagram

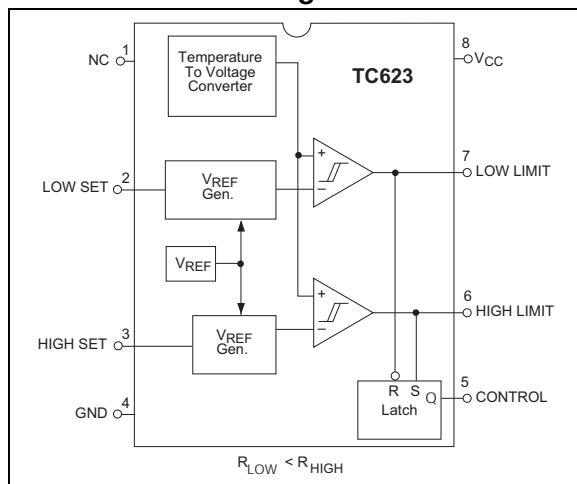

Package Type

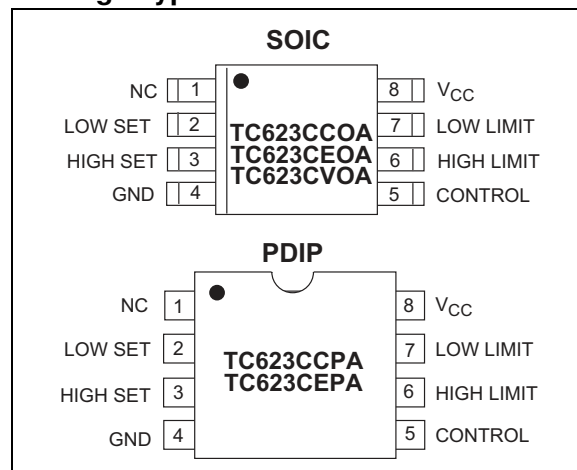

General Description

The TC623 is a 3V solid-state, programmable temperature sensor designed for use in thermal management applications. It features dual thermal interrupt outputs (LOW LIMIT and HIGH LIMIT) each of which are set with an external resistor. The HIGH LIMIT and LOW LIMIT outputs are driven active (high) when measured temperature equals the user programmed limits. The CONTROL output is driven active (high) when temperature equals the HIGH LIMIT set point and turned off when temperature falls below the LOW LIMIT set point. The CONTROL output can be used to provide simple ON/OFF control to a cooling fan if so desired.

Low voltage operation, easy set point programming, small size and low cost make the TC623 an ideal choice for many thermal management applications.

TC623

1.0 ELECTRICAL CHARACTERISTICS

Absolute Maximum Ratings*

| | |
|--|-----------------|
| Supply Voltage | 5.5V |
| Input Voltage Any Input .. (GND – 0.3V) to (V _{DD} +0.3V) | |
| Package Power Dissipation (T _A ≤ 70°C) | |
| Plastic DIP | 730 mW |
| SOIC..... | 470 mW |
| Derating Factors | |
| Plastic DIP | 8 mW/°C |
| SOIC | 6 mW/°C |
| Operating Temperature | |
| V Version | -40°C to +125°C |
| E Version | -40°C to +85°C |
| C Version | 0°C to +70°C |
| Storage Temperature..... | -65°C to +150°C |

*Stresses above those listed under “Absolute Maximum Ratings” may cause permanent damage to the device. These are stress ratings only and functional operation of the device at these or any other conditions above those indicated in the operation sections of the specifications is not implied. Exposure to Absolute Maximum Rating conditions for extended periods may affect device reliability.

TC623 ELECTRICAL SPECIFICATIONS

| Electrical Characteristics: Over Operating Temperature Range, V _{DD} = 2.7V to 4.5V, unless otherwise specified. | | | | | | |
|---|----------------------|-----------------------|------|-----------------------|------|--|
| Symbol | Parameter | Min | Typ. | Max | Unit | Test Conditions |
| V _{DD} | Supply Voltage Range | 2.7 | — | 4.5 | V | |
| I _{DD} | Supply Current | — | 150 | 250 | μA | 2.7V ≤ V _{DD} ≤ 4.5V |
| T _{SET} | Absolute Accuracy | T - 3 | T ±1 | T + 3 | °C | T = Programmed Temperature |
| V _{OH} | Output Voltage High | 0.9 × V _{DD} | — | — | V | I _{OH} = 250 μA I _{OH} = 500 μA |
| | | 0.8 × V _{DD} | — | — | V | |
| V _{OL} | Output Voltage Low | — | — | 0.1 × V _{DD} | V | I _{OL} = 500 μA I _{OL} = 1 mA |
| | | — | — | 0.2 × V _{DD} | V | |
| HYS | Hysteresis | — | — | -2 | °C | Falling Temperature |

2.0 PIN DESCRIPTION

The descriptions of the pins are listed in Table 2-1.

TABLE 2-1: PIN FUNCTION TABLE

| Pin No. (8-Pin SOIC) (8-Pin PDIP) | Symbol | Description |
|---|------------|--|
| 1 | NC | No Internal Connection. |
| 2 | LOW SET | Low temperature set point. Connect an external 1% resistor from LOW SET to V_{DD} to set trip point. |
| 3 | HIGH SET | High temperature set point. Connect an external 1% resistor from HIGH SET to V_{DD} to set trip point. |
| 4 | GND | Ground Terminal. |
| 5 | CONTROL | Control output. |
| 6 | HIGH LIMIT | High temperature push/pull output. |
| 7 | LOW LIMIT | Low temperature push/pull output. |
| 8 | V_{CC} | Power supply input. |

TC623

3.0 DETAILED DESCRIPTION

3.1 TC623 Operation

The TC623 has a positive temperature coefficient (Silicon) temperature sensor and dual threshold detector. Temperature set point programming is accomplished with external resistors from the HIGH SET and LOW SET inputs to V_{CC} . The HIGH LIMIT and LOW LIMIT outputs remain inactive (low) as long as the measured temperature is below set point values. As temperature increases, the LOW LIMIT is driven high when temperature equals the LOW LIMIT set point ($\pm 3^{\circ}\text{C}$). If temperature continues to climb, the HIGH LIMIT output is driven high when temperature equals the HIGH LIMIT set point ($\pm 3^{\circ}\text{C}$).

Figure 3-1 shows the relationship between the sense resistance values and trip point temperature.

FIGURE 3-1: TC623 SENSE RESISTORS VS. TRIP TEMPERATURE

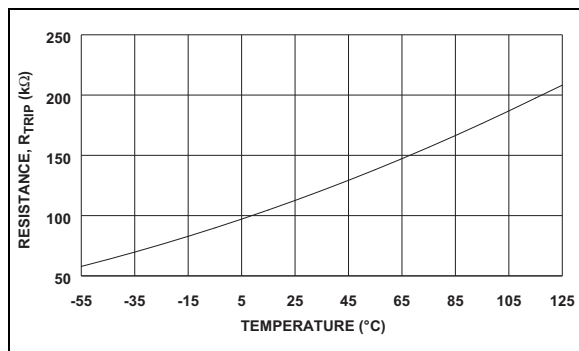

The CONTROL output is driven high when the HIGH LIMIT output goes high and is RESET low when the LOW LIMIT output goes low. This output provides the logic for simple ON/OFF fan control. Figure 3-2 shows overall TC623 operation.

FIGURE 3-2: TC623 TEMPERATURE VS. OUTPUT

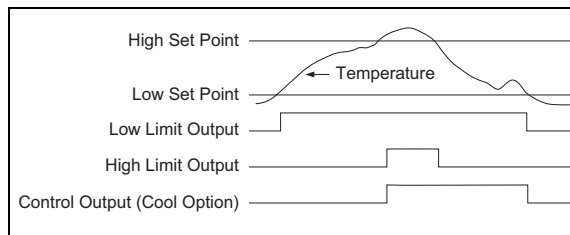

To prevent output “chattering” when measured temperature is at (or near) the trip point values, the LOW SET and HIGH SET inputs each have a built-in hysteresis of -2°C max. As a result, the HIGH LIMIT and LOW LIMIT outputs remain active until the measured temperature falls a maximum of 2°C below the programmed HIGH SET and LOW SET thresholds as shown in Figure 3-3. The programmed setting threshold of Figure 3-3 is user programmed temperature trip points of either the LOW SET or HIGH SET inputs. The LOW LIMIT or HIGH LIMIT output is driven active when temperature equals the set point value (to within 3°C). The output remains active until the temperature falls an additional 2°C below the set point due to hysteresis.

FIGURE 3-3: HIGH SET AND LOW SET THRESHOLDS

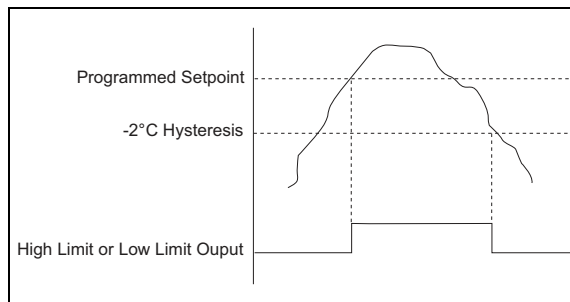

4.0 TYPICAL APPLICATIONS

4.1 Mounting

If the TC623 is used to measure the temperature of another device, it is important that the top surface of the TC623 package be in intimate contact with the measured device. Good thermal conductivity and no air space is critical to accurate temperature measurement in applications of this type.

4.2 Trip Point Programming

The resistance values required for the HIGH SET and LOW SET inputs are calculated using the formula below:

$$R_{\text{TRIP}} = 0.5997 \times T^{2.1312}$$

Where;

R_{TRIP} = Programming resistor value in Ohms
T = Desired trip temperature in degrees Kelvin.

For example, to program a trip point of 50°C, the programming resistor is:

$$R_{\text{TRIP}} = 0.5997 \times (50 + 273.15)^{2.1312} = 133.65 \text{ k}\Omega$$

TC623

5.0 PACKAGING INFORMATION

5.1 Package Marking Information

Package marking data not available at this time.

5.2 Taping Form

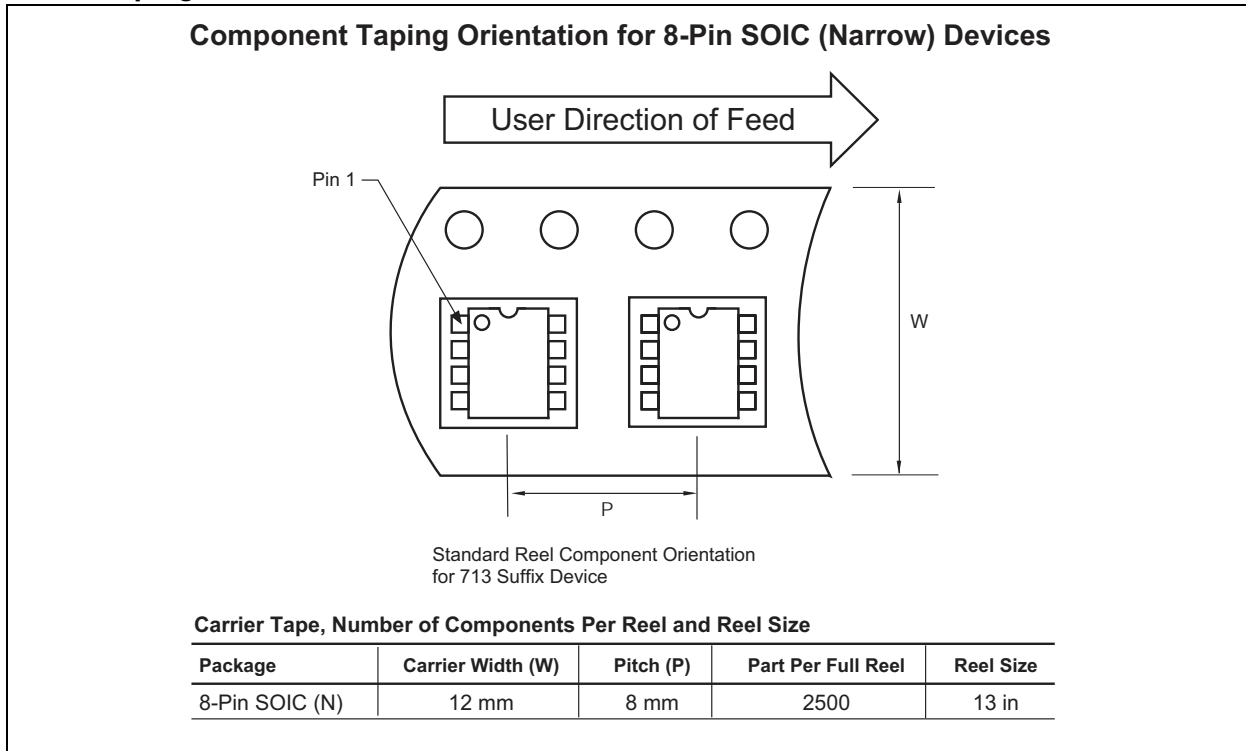

5.3 Package Dimensions

Note: For the most current package drawings, please see the Microchip Packaging Specification located at <http://www.microchip.com/packaging>

8-Pin SOIC

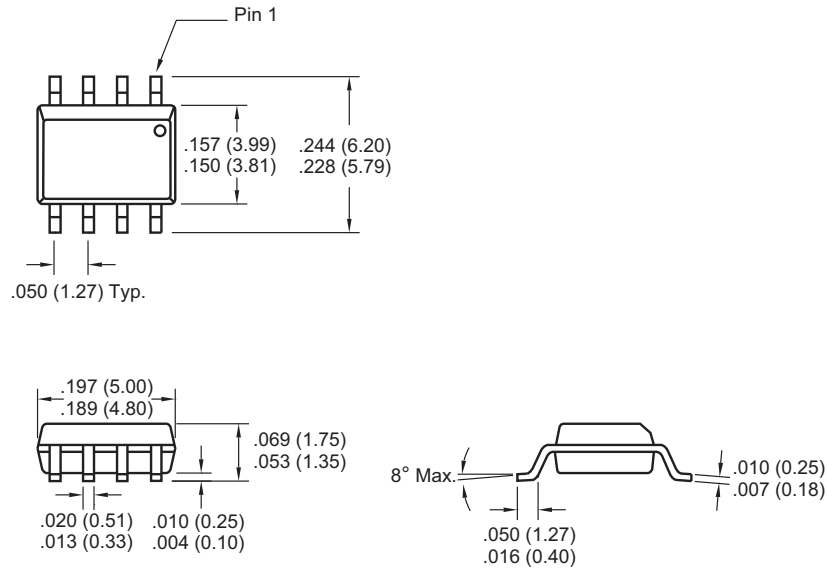

Dimensions: inches (mm)

Note: For the most current package drawings, please see the Microchip Packaging Specification located at <http://www.microchip.com/packaging>

8-Pin Plastic DIP

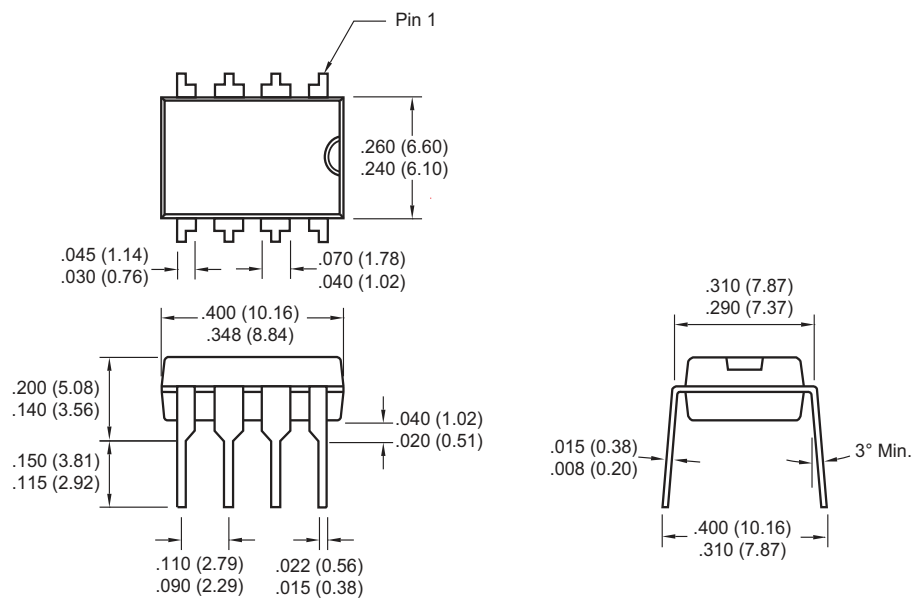

Dimensions: inches (mm)

6.0 REVISION HISTORY

Revision D (December 2012)

Added a note to each package outline drawing.

THE MICROCHIP WEB SITE

Microchip provides online support via our WWW site at www.microchip.com. This web site is used as a means to make files and information easily available to customers. Accessible by using your favorite Internet browser, the web site contains the following information:

- **Product Support** – Data sheets and errata, application notes and sample programs, design resources, user's guides and hardware support documents, latest software releases and archived software
- **General Technical Support** – Frequently Asked Questions (FAQ), technical support requests, online discussion groups, Microchip consultant program member listing
- **Business of Microchip** – Product selector and ordering guides, latest Microchip press releases, listing of seminars and events, listings of Microchip sales offices, distributors and factory representatives

CUSTOMER CHANGE NOTIFICATION SERVICE

Microchip's customer notification service helps keep customers current on Microchip products. Subscribers will receive e-mail notification whenever there are changes, updates, revisions or errata related to a specified product family or development tool of interest.

To register, access the Microchip web site at www.microchip.com. Under "Support", click on "Customer Change Notification" and follow the registration instructions.

CUSTOMER SUPPORT

Users of Microchip products can receive assistance through several channels:

- Distributor or Representative
- Local Sales Office
- Field Application Engineer (FAE)
- Technical Support

Customers should contact their distributor, representative or field application engineer (FAE) for support. Local sales offices are also available to help customers. A listing of sales offices and locations is included in the back of this document.

Technical support is available through the web site at: <http://microchip.com/support>

TC623

READER RESPONSE

It is our intention to provide you with the best documentation possible to ensure successful use of your Microchip product. If you wish to provide your comments on organization, clarity, subject matter, and ways in which our documentation can better serve you, please FAX your comments to the Technical Publications Manager at (480) 792-4150.

Please list the following information, and use this outline to provide us with your comments about this document.

TO: Technical Publications Manager Total Pages Sent _____

RE: Reader Response

From: Name _____

Company _____

Address _____

City / State / ZIP / Country _____

Telephone: (_____) _____ - _____ FAX: (_____) _____ - _____

Application (optional):

Would you like a reply? Y N

Device: TC623

Literature Number: DS21441D

Questions:

1. What are the best features of this document?

2. How does this document meet your hardware and software development needs?

3. Do you find the organization of this document easy to follow? If not, why?

4. What additions to the document do you think would enhance the structure and subject?

5. What deletions from the document could be made without affecting the overall usefulness?

6. Is there any incorrect or misleading information (what and where)?

7. How would you improve this document?

Note the following details of the code protection feature on Microchip devices:

- Microchip products meet the specification contained in their particular Microchip Data Sheet.
- Microchip believes that its family of products is one of the most secure families of its kind on the market today, when used in the intended manner and under normal conditions.
- There are dishonest and possibly illegal methods used to breach the code protection feature. All of these methods, to our knowledge, require using the Microchip products in a manner outside the operating specifications contained in Microchip's Data Sheets. Most likely, the person doing so is engaged in theft of intellectual property.
- Microchip is willing to work with the customer who is concerned about the integrity of their code.
- Neither Microchip nor any other semiconductor manufacturer can guarantee the security of their code. Code protection does not mean that we are guaranteeing the product as “unbreakable.”

Code protection is constantly evolving. We at Microchip are committed to continuously improving the code protection features of our products. Attempts to break Microchip's code protection feature may be a violation of the Digital Millennium Copyright Act. If such acts allow unauthorized access to your software or other copyrighted work, you may have a right to sue for relief under that Act.

Information contained in this publication regarding device applications and the like is provided only for your convenience and may be superseded by updates. It is your responsibility to ensure that your application meets with your specifications. MICROCHIP MAKES NO REPRESENTATIONS OR WARRANTIES OF ANY KIND WHETHER EXPRESS OR IMPLIED, WRITTEN OR ORAL, STATUTORY OR OTHERWISE, RELATED TO THE INFORMATION, INCLUDING BUT NOT LIMITED TO ITS CONDITION, QUALITY, PERFORMANCE, MERCHANTABILITY OR FITNESS FOR PURPOSE. Microchip disclaims all liability arising from this information and its use. Use of Microchip devices in life support and/or safety applications is entirely at the buyer's risk, and the buyer agrees to defend, indemnify and hold harmless Microchip from any and all damages, claims, suits, or expenses resulting from such use. No licenses are conveyed, implicitly or otherwise, under any Microchip intellectual property rights.

Trademarks

The Microchip name and logo, the Microchip logo, dsPIC, FlashFlex, KEELOQ, KEELOQ logo, MPLAB, PIC, PICmicro, PICSTART, PIC³² logo, rPIC, SST, SST Logo, SuperFlash and UNI/O are registered trademarks of Microchip Technology Incorporated in the U.S.A. and other countries.

FilterLab, Hampshire, HI-TECH C, Linear Active Thermistor, MTP, SEEVAL and The Embedded Control Solutions Company are registered trademarks of Microchip Technology Incorporated in the U.S.A.

Silicon Storage Technology is a registered trademark of Microchip Technology Inc. in other countries.

Analog-for-the-Digital Age, Application Maestro, BodyCom, chipKIT, chipKIT logo, CodeGuard, dsPICDEM, dsPICDEM.net, dsPICworks, dsSPEAK, ECAN, ECONOMONITOR, FanSense, HI-TIDE, In-Circuit Serial Programming, ICSP, Mindi, MiWi, MPASM, MPF, MPLAB Certified logo, MPLIB, MPLINK, mTouch, Omniscent Code Generation, PICC, PICC-18, PICDEM, PICDEM.net, PICkit, PICtail, REAL ICE, rLAB, Select Mode, SQI, Serial Quad I/O, Total Endurance, TSHARC, UniWinDriver, WiperLock, ZENA and Z-Scale are trademarks of Microchip Technology Incorporated in the U.S.A. and other countries.

SQTP is a service mark of Microchip Technology Incorporated in the U.S.A.

GestIC and ULPP are registered trademarks of Microchip Technology Germany II GmbH & Co. & KG, a subsidiary of Microchip Technology Inc., in other countries.

All other trademarks mentioned herein are property of their respective companies.

© 2001-2012, Microchip Technology Incorporated, Printed in the U.S.A., All Rights Reserved.

 Printed on recycled paper.

ISBN: 9781620768259

QUALITY MANAGEMENT SYSTEM
CERTIFIED BY DNV
== ISO/TS 16949 ==

Microchip received ISO/TS-16949:2009 certification for its worldwide headquarters, design and wafer fabrication facilities in Chandler and Tempe, Arizona; Gresham, Oregon and design centers in California and India. The Company's quality system processes and procedures are for its PIC[®] MCUs and dsPIC[®] DSCs, KEELOQ[®] code hopping devices, Serial EEPROMs, microperipherals, nonvolatile memory and analog products. In addition, Microchip's quality system for the design and manufacture of development systems is ISO 9001:2000 certified.



MICROCHIP

Worldwide Sales and Service

AMERICAS

Corporate Office
2355 West Chandler Blvd.
Chandler, AZ 85224-6199
Tel: 480-792-7200
Fax: 480-792-7277
Technical Support:
<http://www.microchip.com/support>
Web Address:
www.microchip.com

Atlanta
Duluth, GA
Tel: 678-957-9614
Fax: 678-957-1455

Boston
Westborough, MA
Tel: 774-760-0087
Fax: 774-760-0088

Chicago
Itasca, IL
Tel: 630-285-0071
Fax: 630-285-0075

Cleveland
Independence, OH
Tel: 216-447-0464
Fax: 216-447-0643

Dallas
Addison, TX
Tel: 972-818-7423
Fax: 972-818-2924

Detroit
Farmington Hills, MI
Tel: 248-538-2250
Fax: 248-538-2260

Indianapolis
Noblesville, IN
Tel: 317-773-8323
Fax: 317-773-5453

Los Angeles
Mission Viejo, CA
Tel: 949-462-9523
Fax: 949-462-9608

Santa Clara
Santa Clara, CA
Tel: 408-961-6444
Fax: 408-961-6445

Toronto
Mississauga, Ontario,
Canada
Tel: 905-673-0699
Fax: 905-673-6509

ASIA/PACIFIC

Asia Pacific Office
Suites 3707-14, 37th Floor
Tower 6, The Gateway
Harbour City, Kowloon
Hong Kong
Tel: 852-2401-1200
Fax: 852-2401-3431

Australia - Sydney
Tel: 61-2-9868-6733
Fax: 61-2-9868-6755

China - Beijing
Tel: 86-10-8569-7000
Fax: 86-10-8528-2104

China - Chengdu
Tel: 86-28-8665-5511
Fax: 86-28-8665-7889

China - Chongqing
Tel: 86-23-8980-9588
Fax: 86-23-8980-9500

China - Hangzhou
Tel: 86-571-2819-3187
Fax: 86-571-2819-3189

China - Hong Kong SAR
Tel: 852-2943-5100
Fax: 852-2401-3431

China - Nanjing
Tel: 86-25-8473-2460
Fax: 86-25-8473-2470

China - Qingdao
Tel: 86-532-8502-7355
Fax: 86-532-8502-7205

China - Shanghai
Tel: 86-21-5407-5533
Fax: 86-21-5407-5066

China - Shenyang
Tel: 86-24-2334-2829
Fax: 86-24-2334-2393

China - Shenzhen
Tel: 86-755-8864-2200
Fax: 86-755-8203-1760

China - Wuhan
Tel: 86-27-5980-5300
Fax: 86-27-5980-5118

China - Xian
Tel: 86-29-8833-7252
Fax: 86-29-8833-7256

China - Xiamen
Tel: 86-592-2388138
Fax: 86-592-2388130

China - Zhuhai
Tel: 86-756-3210040
Fax: 86-756-3210049

ASIA/PACIFIC

India - Bangalore
Tel: 91-80-3090-4444
Fax: 91-80-3090-4123

India - New Delhi
Tel: 91-11-4160-8631
Fax: 91-11-4160-8632

India - Pune
Tel: 91-20-2566-1512
Fax: 91-20-2566-1513

Japan - Osaka
Tel: 81-6-6152-7160
Fax: 81-6-6152-9310

Japan - Tokyo
Tel: 81-3-6880-3770
Fax: 81-3-6880-3771

Korea - Daegu
Tel: 82-53-744-4301
Fax: 82-53-744-4302

Korea - Seoul
Tel: 82-2-554-7200
Fax: 82-2-558-5932 or
82-2-558-5934

Malaysia - Kuala Lumpur
Tel: 60-3-6201-9857
Fax: 60-3-6201-9859

Malaysia - Penang
Tel: 60-4-227-8870
Fax: 60-4-227-4068

Philippines - Manila
Tel: 63-2-634-9065
Fax: 63-2-634-9069

Singapore
Tel: 65-6334-8870
Fax: 65-6334-8850

Taiwan - Hsin Chu
Tel: 886-3-5778-366
Fax: 886-3-5770-955

Taiwan - Kaohsiung
Tel: 886-7-213-7828
Fax: 886-7-330-9305

Taiwan - Taipei
Tel: 886-2-2508-8600
Fax: 886-2-2508-0102

Thailand - Bangkok
Tel: 66-2-694-1351
Fax: 66-2-694-1350

EUROPE

Austria - Wels
Tel: 43-7242-2244-39
Fax: 43-7242-2244-393

Denmark - Copenhagen
Tel: 45-4450-2828
Fax: 45-4485-2829

France - Paris
Tel: 33-1-69-53-63-20
Fax: 33-1-69-30-90-79

Germany - Munich
Tel: 49-89-627-144-0
Fax: 49-89-627-144-44

Italy - Milan
Tel: 39-0331-742611
Fax: 39-0331-466781

Netherlands - Drunen
Tel: 31-416-690399
Fax: 31-416-690340

Spain - Madrid
Tel: 34-91-708-08-90
Fax: 34-91-708-08-91

UK - Wokingham
Tel: 44-118-921-5869
Fax: 44-118-921-5820

11/29/12