

## A premium developer's tool for sensor hub applications

Data brief



### Features

- STM32F439IIH6 High Performance MCU ARM® Cortex™-M4F @ 180 MHz with 256 KB of embedded SRAM
- 8 MB external SRAM
- IMU 9 axes inertial sensor: LSM9DS1
- Environmental sensors: Pressure (LPS25HB), Humidity and Temperature (HTS221), UV index (UVVIS25M).
- Proximity and ambient light sensors (2x VL6180X)
- Digital MEMS microphone array (4x MP34DT01)
- USB connector
- Micro SD card expansion
- GPIO expansion for pin control and connection to the STM32Nucleo board thanks to the adapter board included in the package

### Description

STEVAl-ID1001V1 is an evaluation board based on the STM32F4 Microcontroller and a wide range of ST sensors. With a small form factor (4 x 4 cm), it represents an integration of sensors and CPU for a “sensor hub like” application. The hardware is compatible with STM32Nucleo and X-NUCLEO expansion boards. The included adapter board is an expansion board that allows the interoperability between STEVAL-ID1001V1, STM32Nucleo and various X-NUCLEO expansions. Expansion boards can be connected either via Arduino or morpho connectors. The evaluation board comes with built-in data logging firmware. It allows streaming and storing of the selected sensor measurements via USB or via bluetooth low energy if an X-NUCLEO-IDB04A1 (or X-NUCLEO-IDB05A1) is plugged through the adapter board. The acquired data can be used to implement new advanced algorithms.

# 1 Schematic diagrams

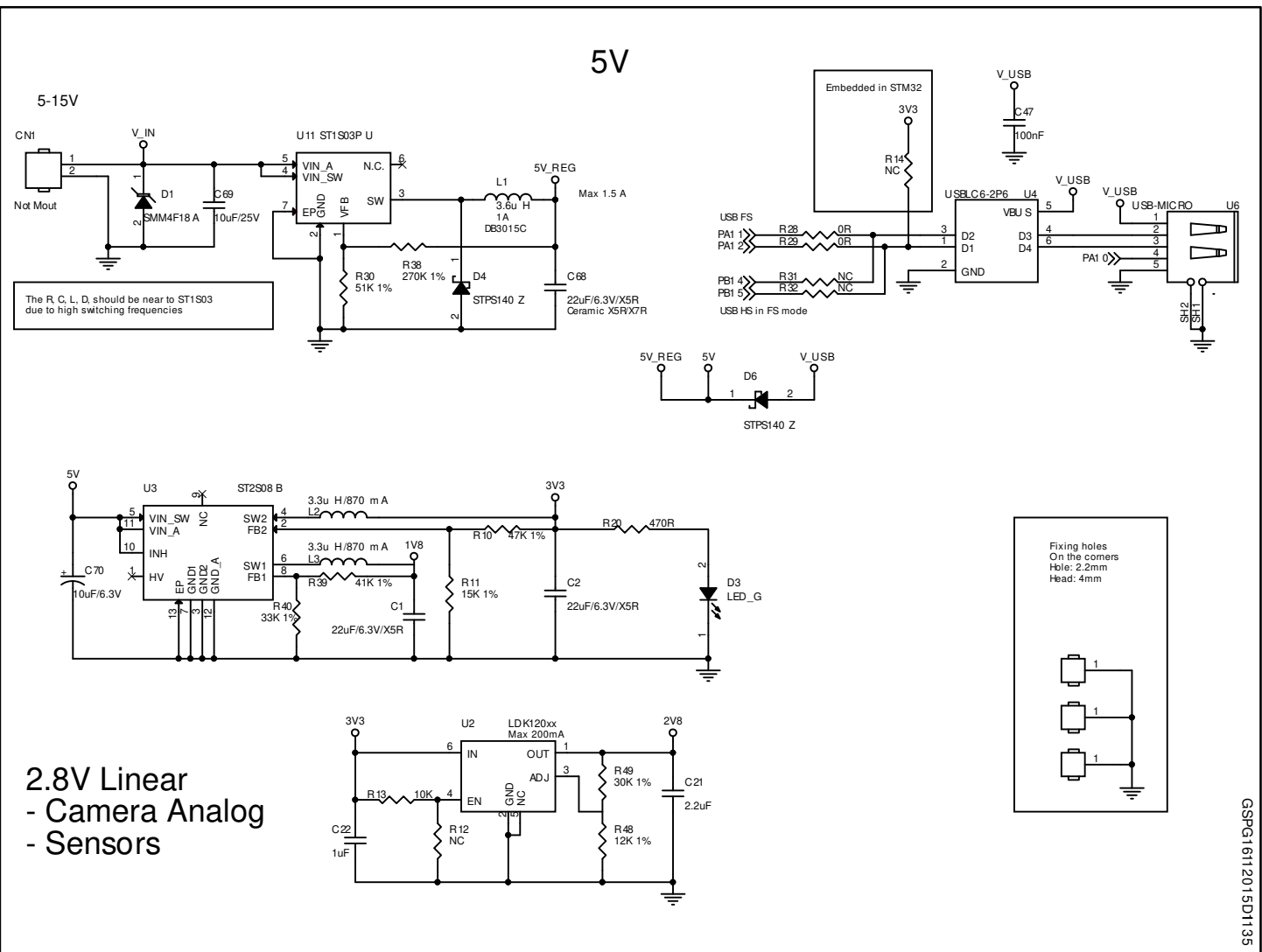

Figure 1: STEVAL-ID1001V1 board schematic part 1

GSPG16112015D1135





Figure 3: STEVAL-ID1001V1 board schematic part 3

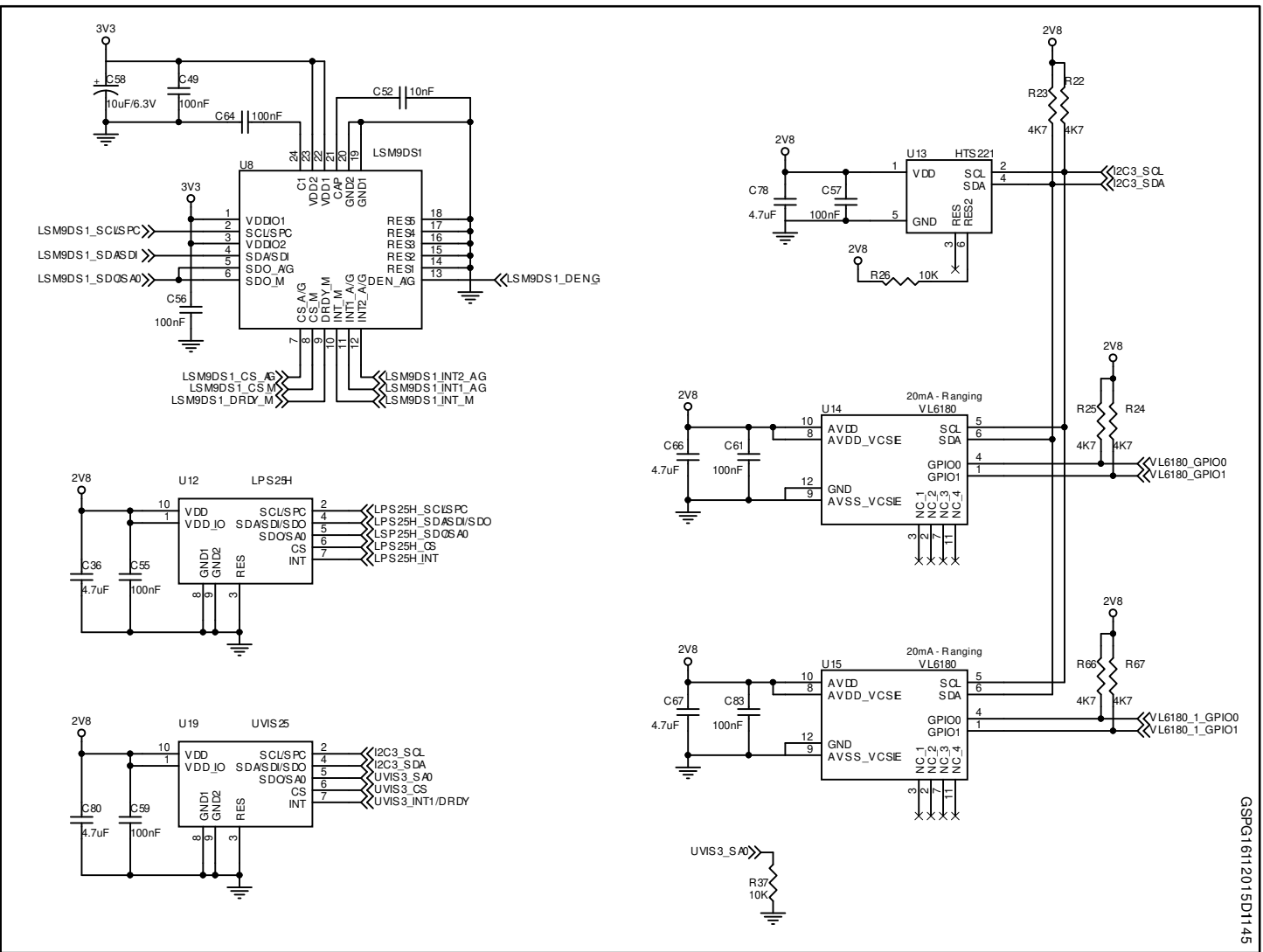

GSPRG16112015PD1145



Figure 4: STEVAL-ID1001V1 board schematic part 4

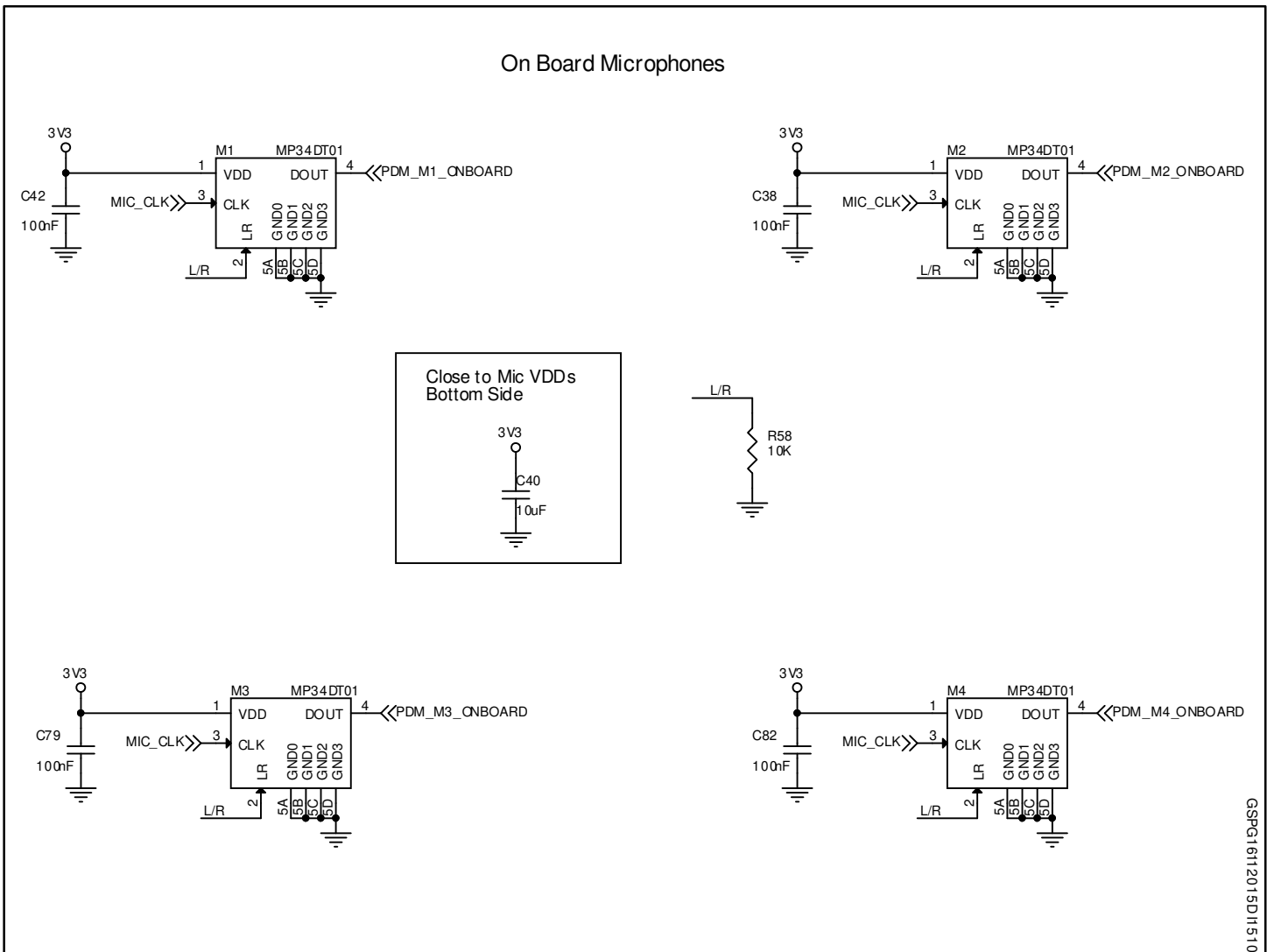

GSPG16112015D1H510

Figure 5: STEVAL-IDI001V1 board schematic part 5

GSPG16112015D1H515

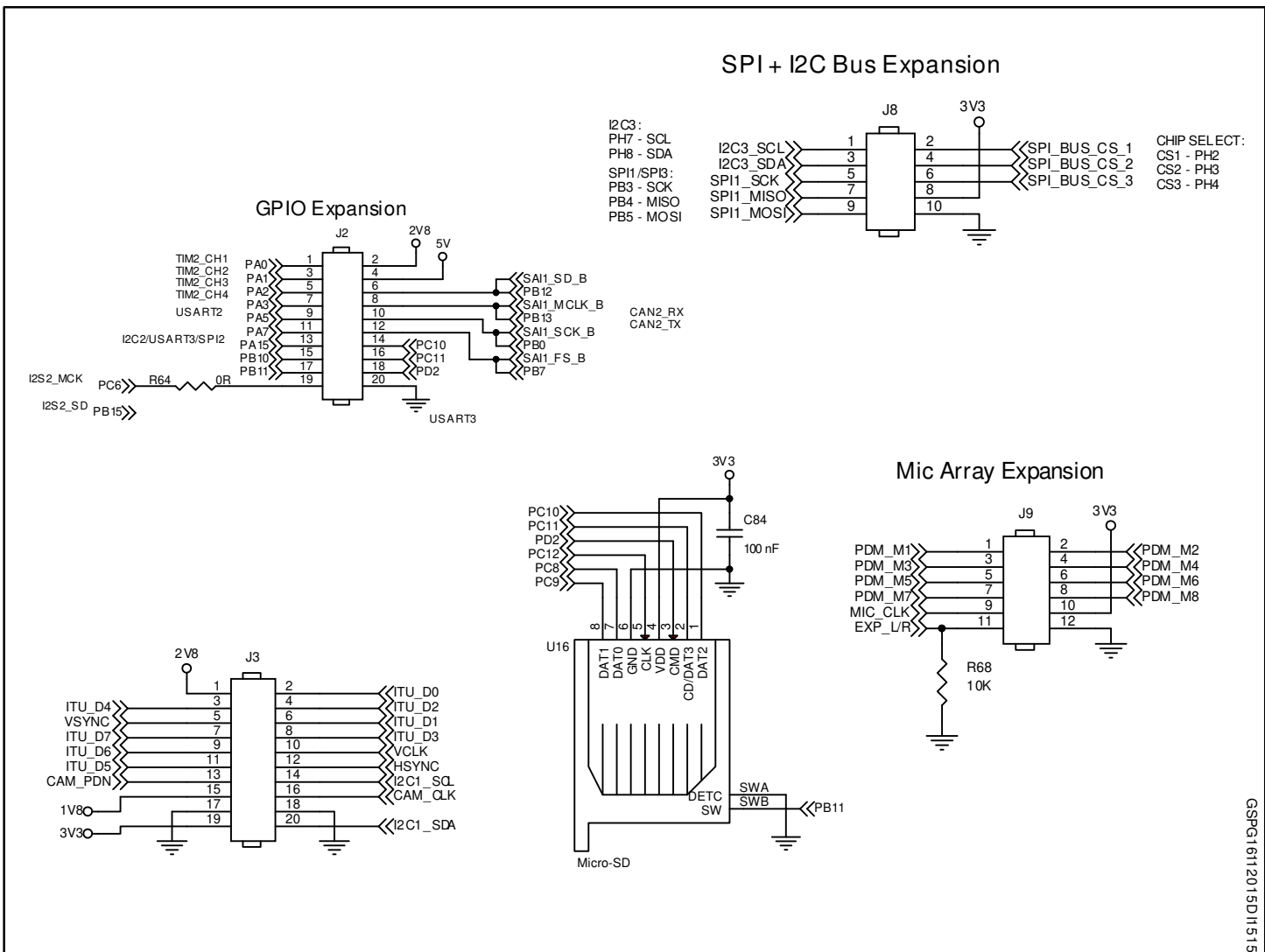

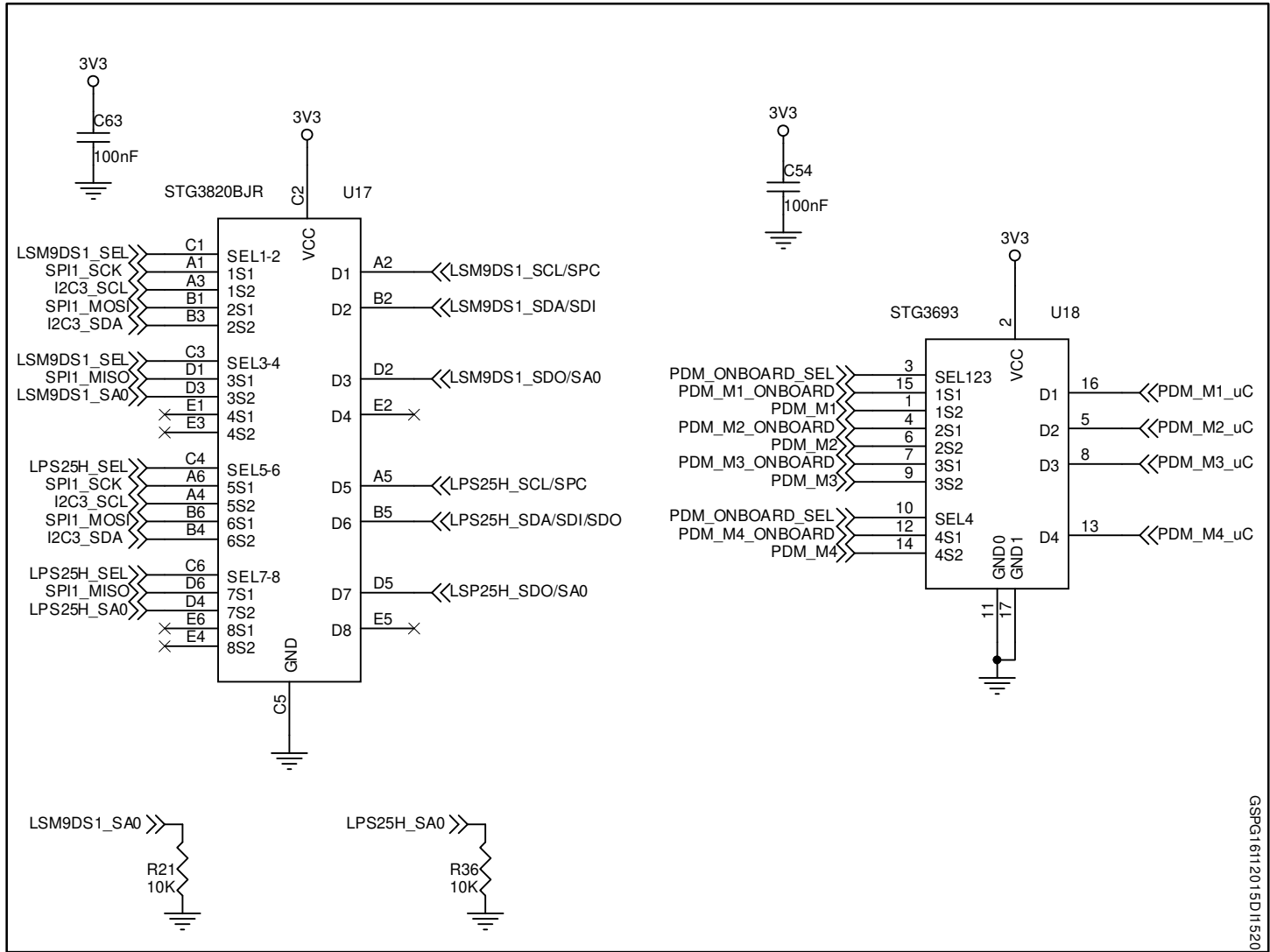

## 2 Revision history

Table 1 : Document revision history

Date	Version	Changes
17-Nov-2015	1	Initial release.



**IMPORTANT NOTICE – PLEASE READ CAREFULLY**

STMicroelectronics NV and its subsidiaries ("ST") reserve the right to make changes, corrections, enhancements, modifications, and improvements to ST products and/or to this document at any time without notice. Purchasers should obtain the latest relevant information on ST products before placing orders. ST products are sold pursuant to ST's terms and conditions of sale in place at the time of order acknowledgement.

Purchasers are solely responsible for the choice, selection, and use of ST products and ST assumes no liability for application assistance or the design of Purchasers' products.

No license, express or implied, to any intellectual property right is granted by ST herein.

Resale of ST products with provisions different from the information set forth herein shall void any warranty granted by ST for such product.

ST and the ST logo are trademarks of ST. All other product or service names are the property of their respective owners.

Information in this document supersedes and replaces information previously supplied in any prior versions of this document.

© 2015 STMicroelectronics – All rights reserved

