

REV. B		SHEET 1 OF 4		DOCUMENT NO. 10-504637-004	
REVISIONS					
LTR	DESCRIPTION	DATE			
A	PRODUCTION RELEASE	6/13/11			
B	CL(11) SEE CHANGE NOTICE ECN: B2374	1/23/12 RKC			

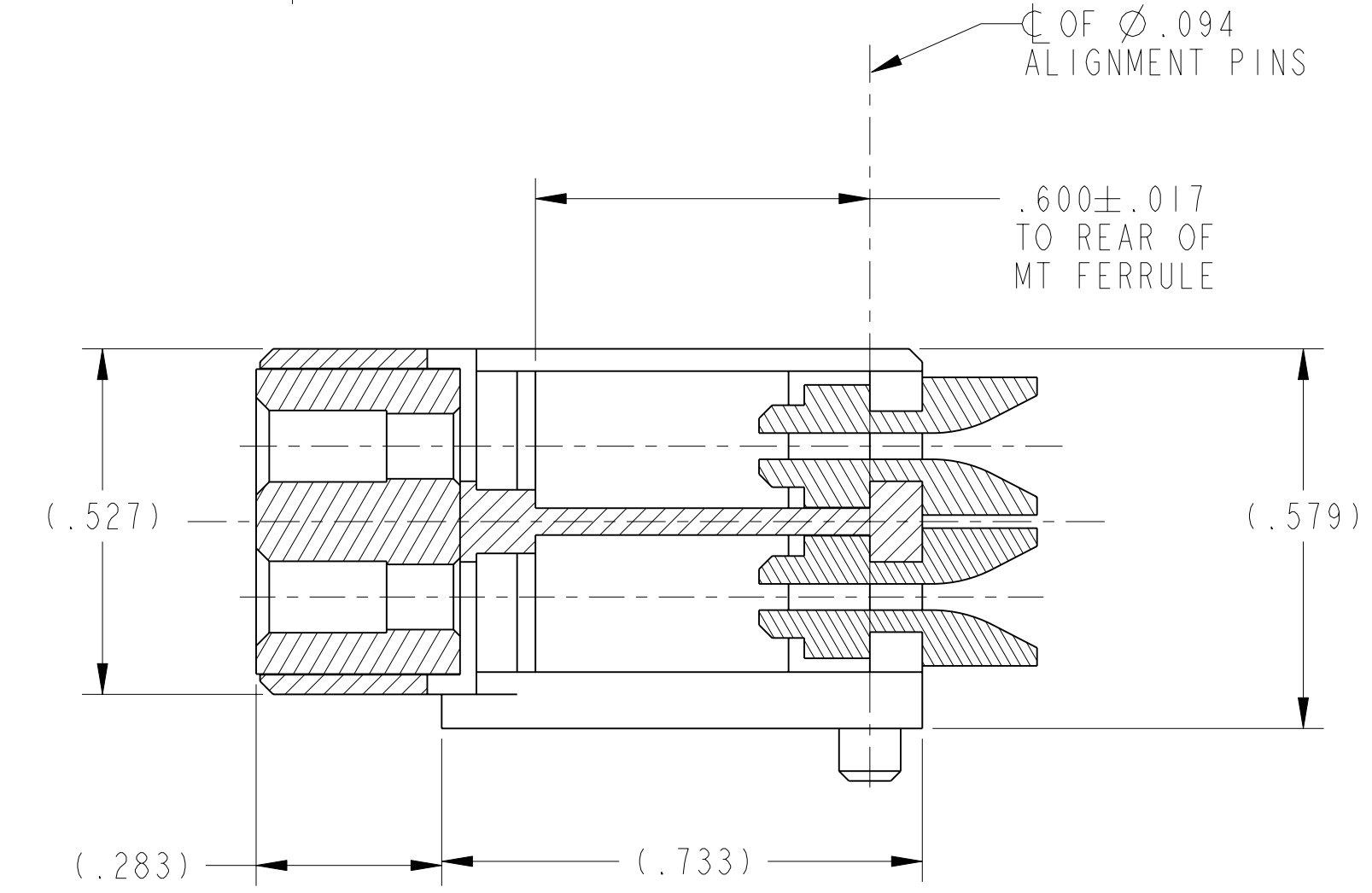
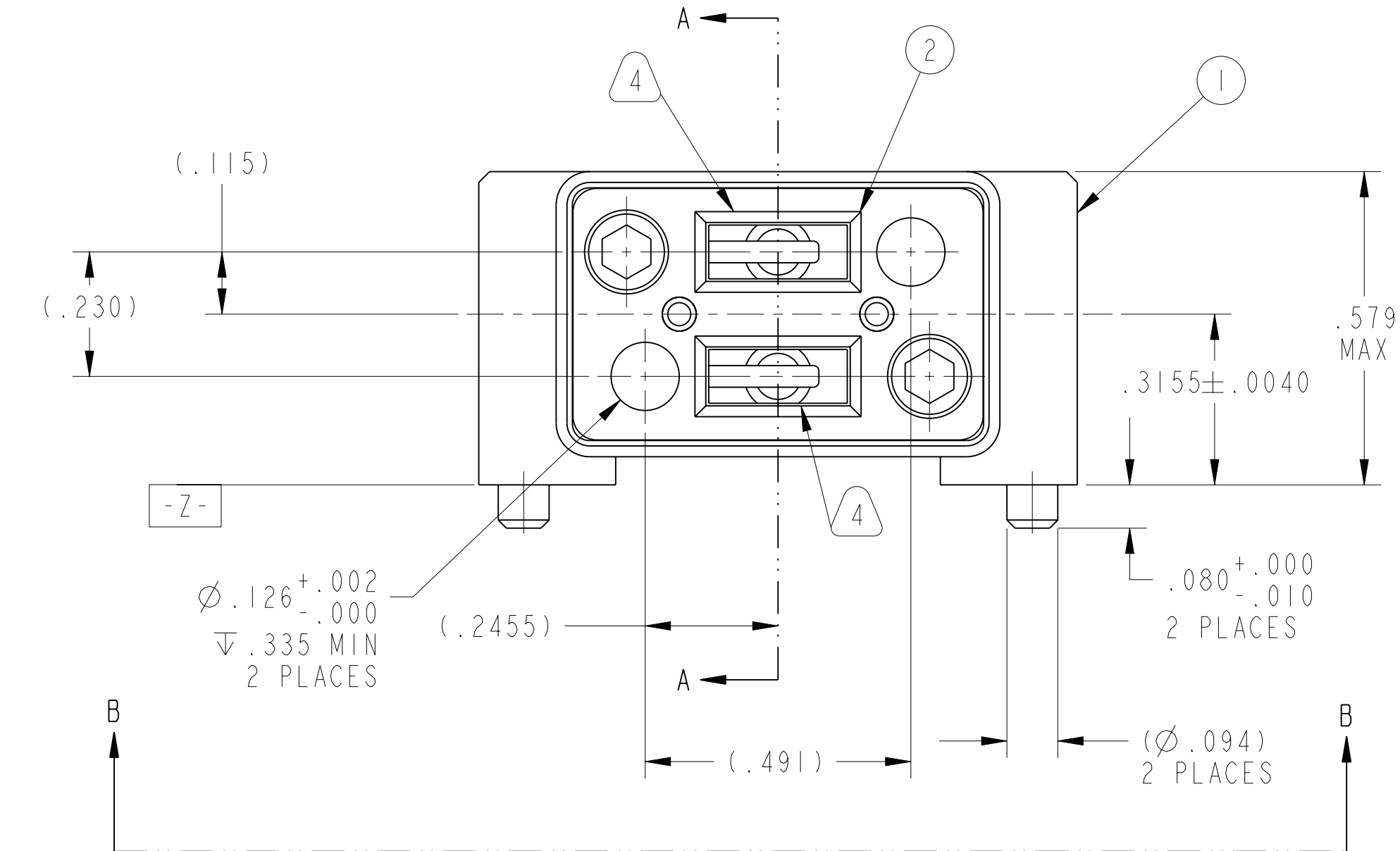
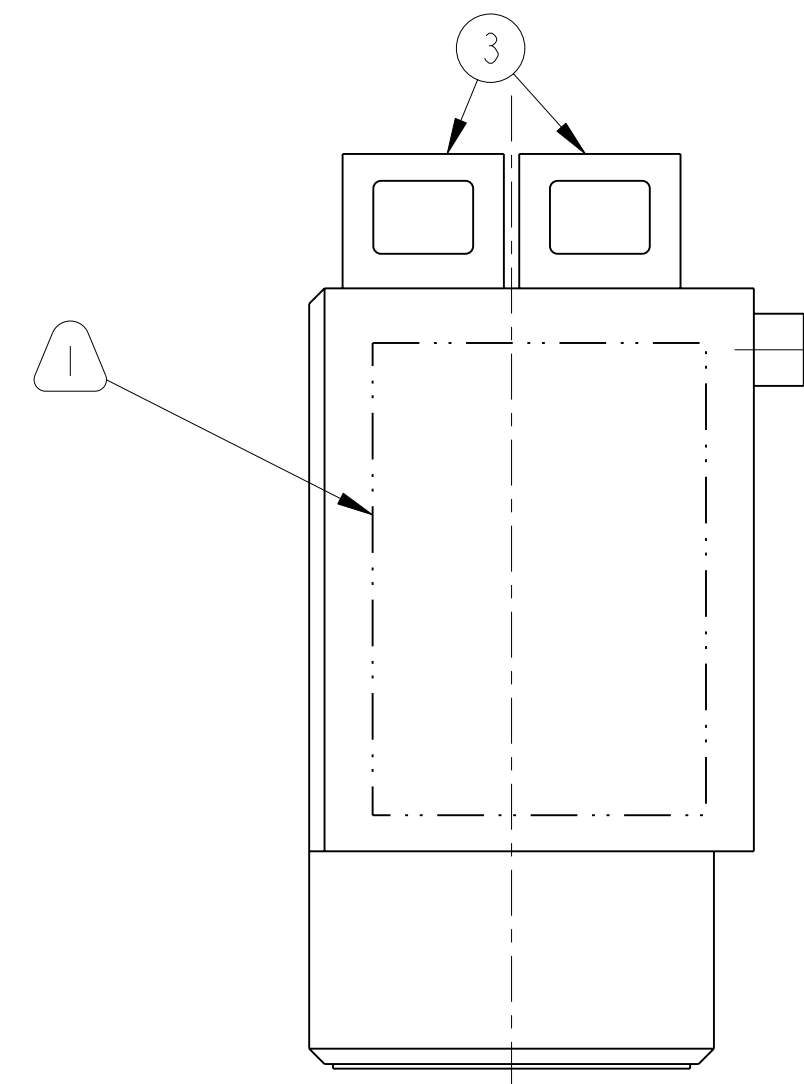
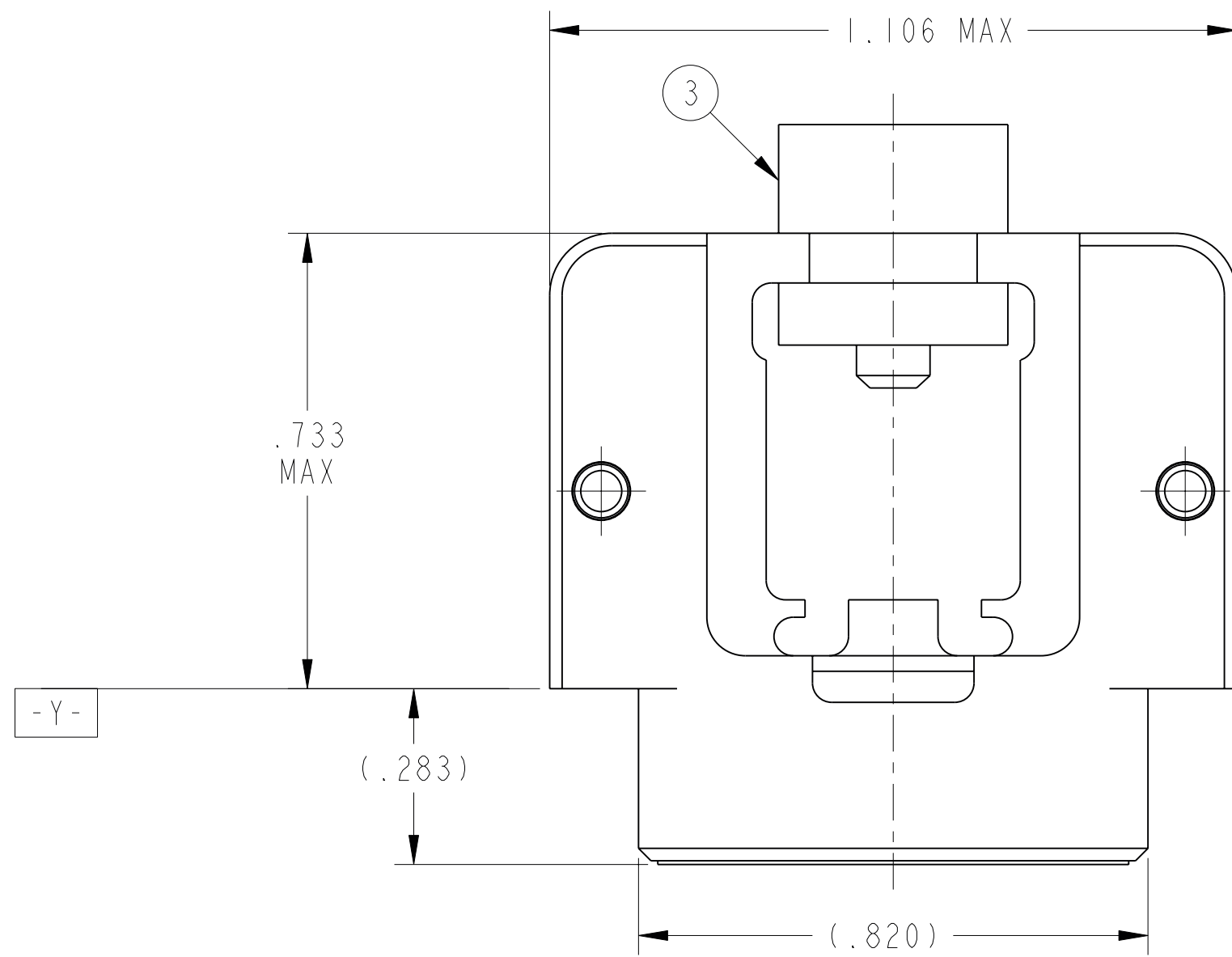

SECTION A-A

POS	QTY	PART NUMBER	DESCRIPTION	NOTE
4	4	10-504808-007	MT PIN CLAMP ASSEMBLY	
3	2	10-504819-003	STRAIN RELIEF	
2	1	10-504819-007	MT FRONT INSERT ASSEMBLY	
1	1	10-504638-019	MAIN BODY	

APPROVALS		DATE	PARTS LIST	
PREPARED BY	R. CHAPMAN	13-Jan-11	AMPHENOL CORPORATION 40-60 DELAWARE AVENUE SIDNEY, N.Y. 13838	
ENGINEER IN CHARGE	E. HICKEY			
DESIGN MANAGER	E. HICKEY			
DESIGN ACTIVITY GROUP	BLP			
THIRD ANGLE PROJECTION			SIZE	CAGE CODE
			C	77820
			DOCUMENT NO.	REV.
			10-504637-004	B
SCALE: 2.0 REF: 10-504637-003			SHEET 1 OF 4	

NOTES: SEE SHEET 2
 THE USE OF THIS DOCUMENT IS UNLIMITED. HOWEVER, DOCUMENTS REFERENCED HEREON MAY CONTAIN LIMITED RIGHTS DATA.

PRO/ENGINEER INFORMATION	
N/A	Pro/e Model Used:
N/A	10-504637-004.ASSEM
N/A	Drawing Name:
N/A	10-504637-004

UNLESS OTHERWISE SPECIFIED
 LINEAR DIMENSIONS ARE IN INCHES
 TOLERANCES:
 .XXXX = ±.0005 ANGLES = ±2°
 .XXX = ±.010
 .XX = ±.03
 .X = ±.1
 DIM. & TOL. PER ASME Y14.5M;
 DRM PER MIL-DTL-31000;
 OTHER Amphenol Sds. PER 9-3800
 LEGENDS:
 = FLAG NOTE CALL OUT REFERENCE ONLY

SCALE 4.000

DOCUMENT NO. 10-504637-004
 SHEET 1 OF 4
 REV. B
 C
 B
 A

DOCUMENT NO. 10-504637-004
 SHEET 1 OF 4
 REV. B
 C
 B
 A

10-504637-004
DOCUMENT NO.
SHEET 2 OF 4
REV. B

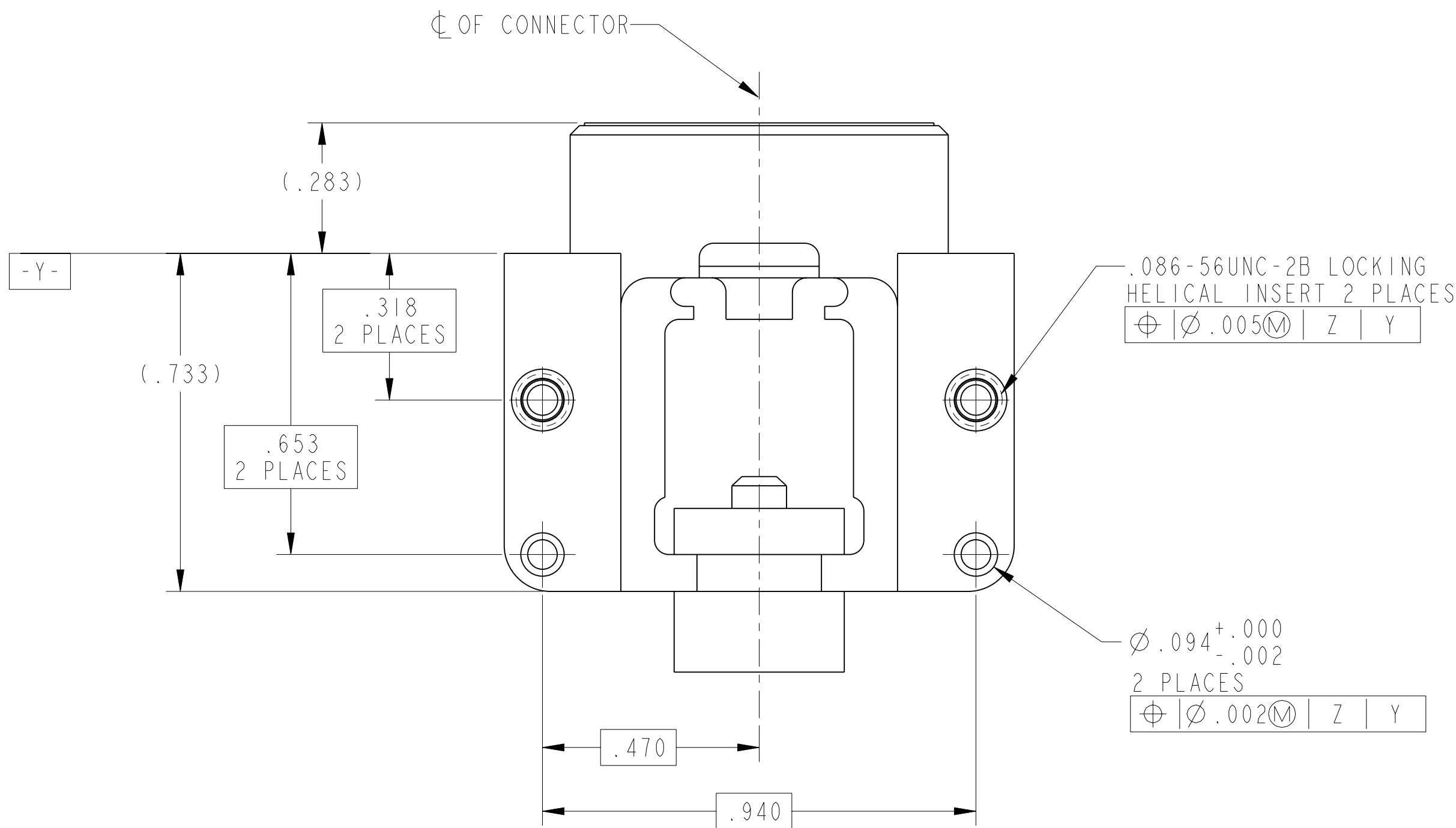

VIEW AT B

7. MT FERRULE (NOT INCLUDED) CAN NOT BE INSTALLED OR REMOVED UNLESS INSERT IS REMOVED FROM ASSEMBLY FIRST. REMOVE CONNECTOR FROM BOARD TO ACCESS MT FERRULE CLOSE TO BOARD.
6. FRONT INSERT ASSEMBLY, STRAIN RELIEFS AND MT PIN CLAMP ASSEMBLIES ARE SHIPPED UNASSEMBLED.
5. FRONT INSERT (F/N 2) IS REMOVABLE ONCE CONNECTOR IS ATTACHED TO MODULE FOR CLEANING BY UNTHREADING CAPTIVE SCREWS. SCREWS SHOULD BE INSTALLED TO 10-14 IN-OZ.
4. INSERT CAVITIES ARE FOR FIBER OPTIC MT FERRULES PER IEC 1754-5-4. MT FERRULES AND ASSOCIATED RIBBON CABLE ARE NOT PART OF THIS ASSEMBLY. GUIDE PINS FOR MT FERRULES ARE INCLUDED (F/N 4) IN THE ASSEMBLY.
3. FOR CONNECTOR INSTALLATION ILLUSTRATION AND MATED DIMENSIONS SEE SHEET 3.
2. FOR MATING BACKPLANE CONNECTOR ASSEMBLY, SEE DRAWING 10-504639-002.
1. BLACK INK STAMP "AMPHENOL" PART NUMBER AND DATE CODE ON INDICATED SURFACE PER 9-3856-5. DATE CODE PER 9-3895. CHARACTERS TO BE .062±.020 HIGH. ADDITIONAL INFORMATION MAY BE REQUESTED BY PURCHASE ORDER. STAMPING CAN BE ON BOTH SIDES OF PART.

THE USE OF THIS DOCUMENT IS UNLIMITED. HOWEVER, DOCUMENTS REFERENCED HEREON MAY CONTAIN LIMITED RIGHTS DATA.

SIZE C	CAGE CODE 77820	DOCUMENT NO. 10-504637-004	REV. B
SCALE: 2.0	REF. 10-504637-003	SHEET 2 OF 4	

10-504637-004
DOCUMENT NO.
SHEET 2 OF 4
REV. B

CONNECTOR LOCATION ON MODULE PCB

POSITION	DIM "X" MM (INCH)
P2	53.73 (2.1154)
P3	96.55 (3.8012)
P4	125.35 (4.9350)
P5	154.15 (6.0689)
P6	182.95 (7.2028)

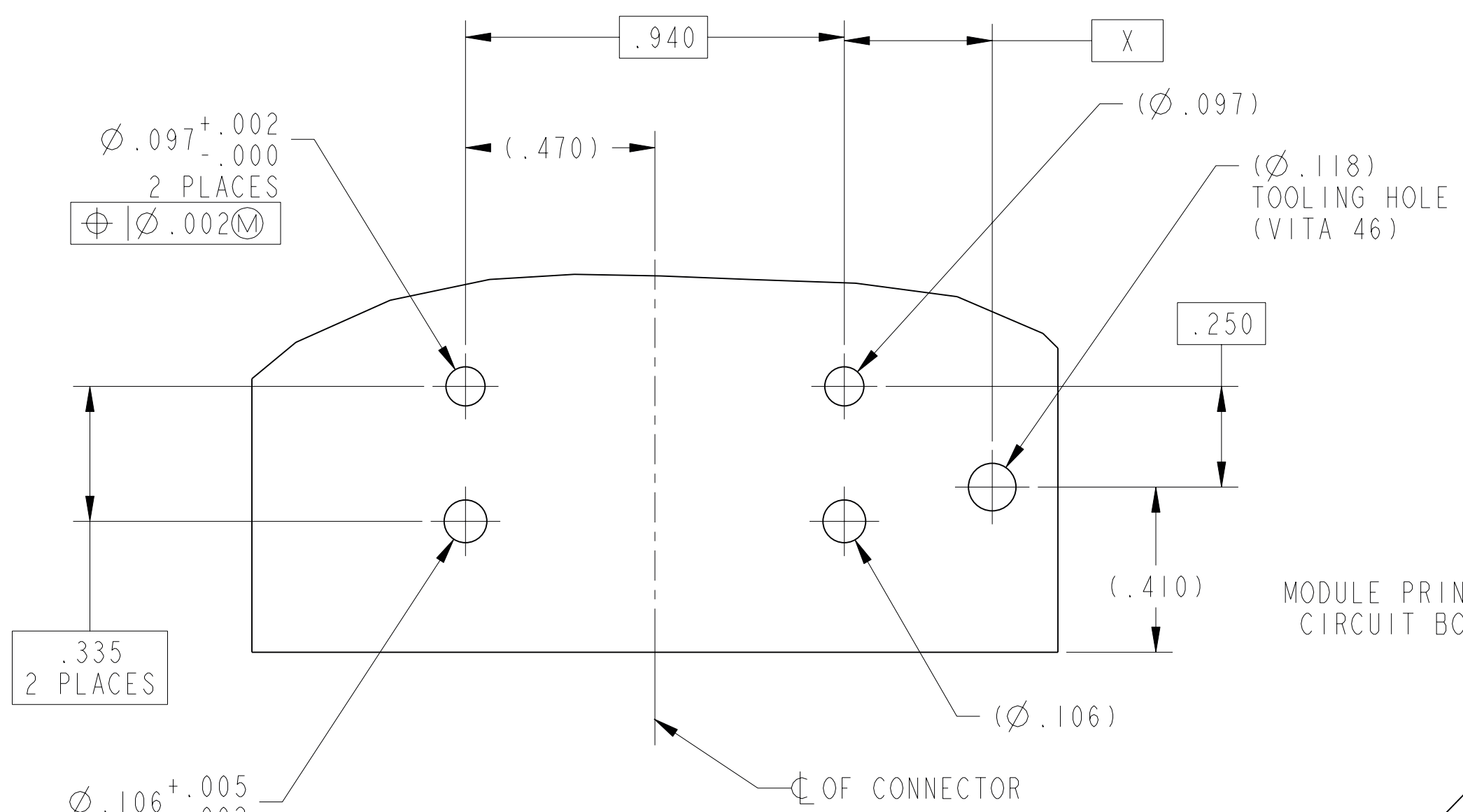

SUGGESTED MODULE PCB INTERFACE DIMENSIONS
 SCALE 3.000

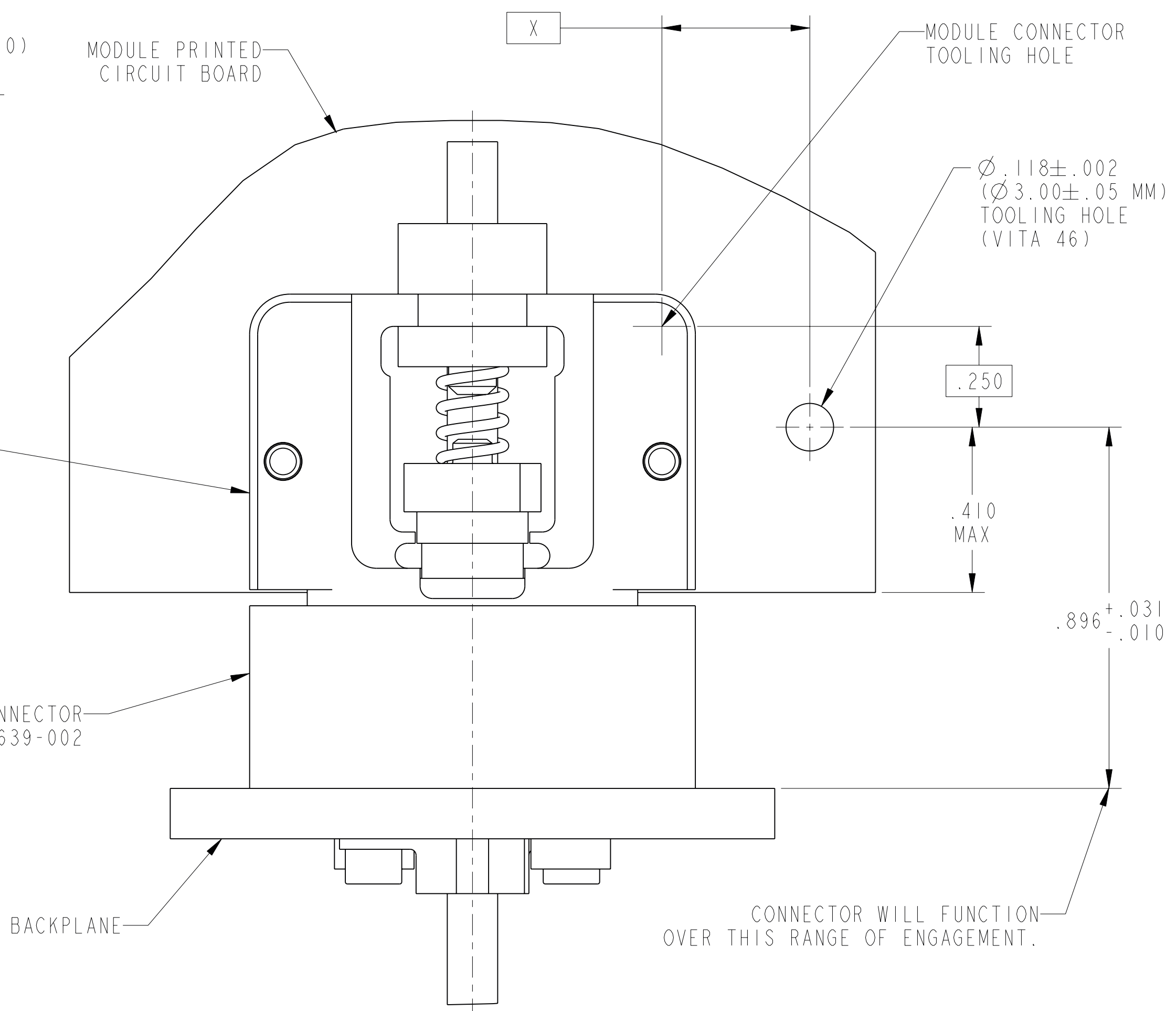

CONNECTOR INSTALLATION ILLUSTRATION AND MATED DIMENSIONS
 SCALE 4.000

SIZE C	CAGE CODE 77820	DOCUMENT NO. 10-504637-004	REV. B
SCALE: 2.0	REF. 10-504637-003	SHEET 3 OF 4	

THE USE OF THIS DOCUMENT IS UNLIMITED. HOWEVER, DOCUMENTS REFERENCED HEREON MAY CONTAIN LIMITED RIGHTS DATA.

10-504637-004

SHEET 3 OF 4

REV. B

C

B

A

FORMAT: C-ULE, Rev. B

D

C

REV. B

SHEET 3 OF 4

10-504637-004

A

10-504637-004
SHEET 4 OF 4
REV. B

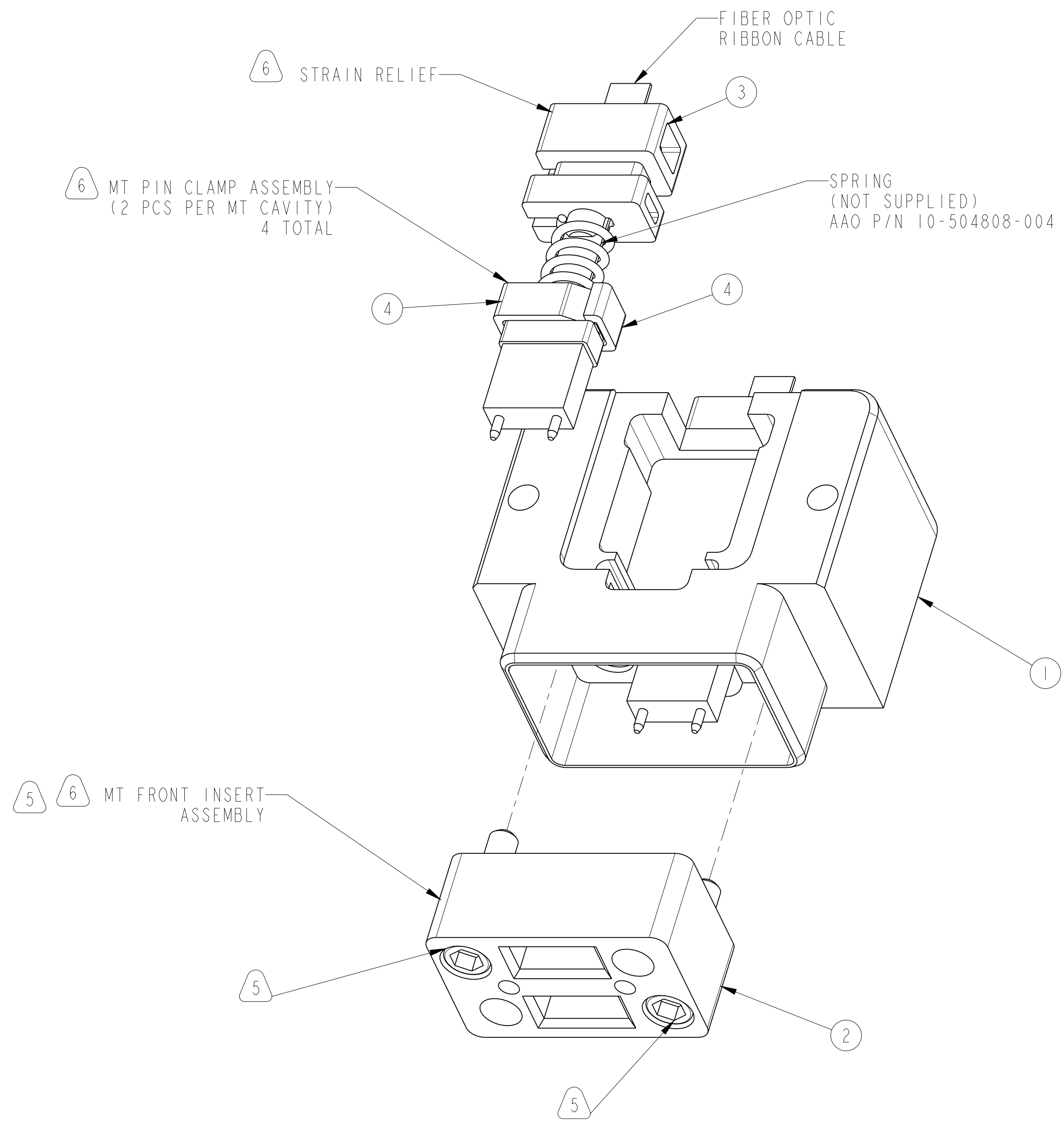

**EXPLODED VIEW OF
MT ASSEMBLY**

SCALE 4.000

THE USE OF THIS DOCUMENT IS UNLIMITED.
HOWEVER, DOCUMENTS REFERENCED HEREON
MAY CONTAIN LIMITED RIGHTS DATA.

SIZE C	CAGE CODE 77820	DOCUMENT NO. 10-504637-004	REV. B
SCALE: 2.0	REF. 10-504637-003	SHEET 4 OF 4	

10-504637-004
SHEET 4 OF 4
REV. B