

THIS DRAWING IS UNPUBLISHED. RELEASED FOR PUBLICATION
 BY AMP INCORPORATED. ALL RIGHTS RESERVED.

LOC	DIST	REVISIONS			
P	LTR	DESCRIPTION	DATE	DWN	APVD
DF	SO	G	REV & REDRAWN; 0600-6242-97	4-97	CT SG

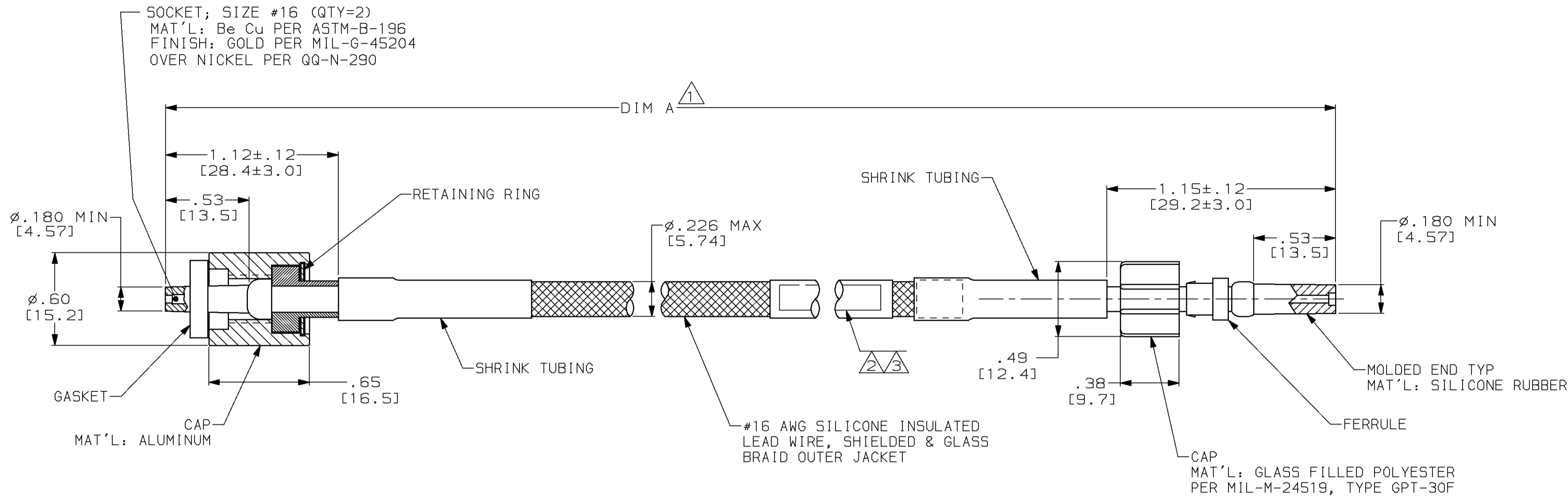

- 1 TOLERANCE OF LEAD LENGTH:
UP TO 24 INCHES [609.6] = ±.12 [±3.0]
24 INCHES [609.6] & UP = ±1%
- 2 AMP INFORMATION MARKED PER MIL-STD-130.
- 3 CUSTOMER MARKING MARKED PER MIL-STD-130 OPPOSITE AMP INFO ON -1 ONLY.
- 4. TO MATE WITH AMP LGH-1/2 RECEPTACLE WITH .53 [13.5] BARREL DEPTH.

OBSOLETE	-	24.00 [609.6]	863330-2
	3A2P2	18.00 [457.2]	863330-1
CUSTOMER MARKING	DIM A 1		PART NO.

THIS DRAWING IS A CONTROLLED DOCUMENT.

DIMENSIONS: INCHES [mm]	TOLERANCES UNLESS OTHERWISE SPECIFIED: 0 PLC ±- 1 PLC ±- 2 PLC ±.02 [0.5] 3 PLC ±.005 [0.13] 4 PLC ±- ANGLES ±- FINISH -	DWN C.C. THOMAS 4-21-97 CHK S. GLATFELTER 5-5-97 APVD S. GLATFELTER 5-5-97	NAME AMP AMP Incorporated Harrisburg, PA 17105-3608
MATERIAL -	FINISH -	PRODUCT SPEC - APPLICATION SPEC - WEIGHT -	LEAD ASSY, DBL END, RFI SHIELDED, LGH-1/2
CUSTOMER DRAWING		SIZE A2 CAGE CODE 00779	DRAWING NO. 863330
		SCALE 2:1	SHEET 1 OF 1 REV G