

IS31BL3212 3-CHANNEL CONSTANT CURRENT LED DRIVER

DESCRIPTION

The IS31BL3212 provides three regulated current sources, delivers up to 23mA of load current to accommodate three white LEDs. It requires no charge pump, has no noise and significantly improved the efficiency.

The serial digital input is used to enable, disable, and set current for each LED with 16 settings down to 0.69mA.

FEATURES

- Supply voltage range from 2.7V to 5.5V
- Ultra low headroom voltage
- Cost effective LED driver
- Three channel constant current output ideal for driving LEDs
- Best Noise and Efficiency Performance
- Ultra low quiescent supply current: 1.0mA (Typ.)
- Highly integrated design, minimal component
- Low shutdown current: 1.0µA (Typ.)
- SOT-6 package

QUICK START

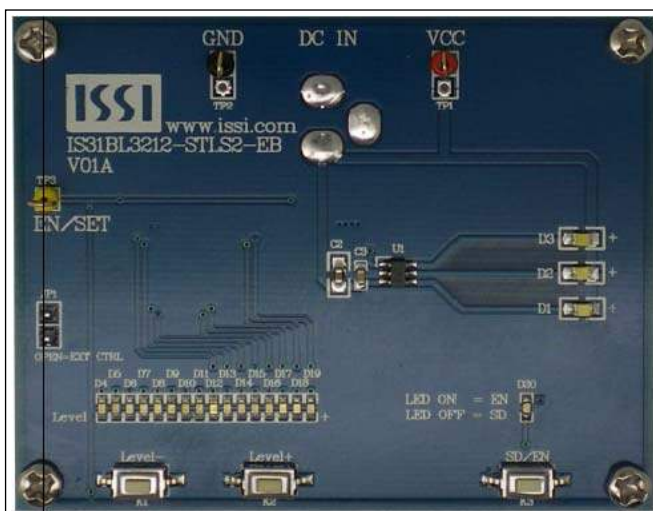

Figure 1: Photo of IS31BL3212 Evaluation Board

RECOMMENDED EQUIPMENT

- 5.0V, 2A power supply

ABSOLUTE MAXIMUM RATINGS

- ≤ 5.5V power supply

Caution: Do not exceed the conditions listed above, otherwise the board will be damaged.

PROCEDURE

The IS31BL3212 evaluation board is fully assembled and tested. Follow the steps listed below to verify board operation.

Caution: Do not turn on the power supply until all connections are completed.

- 1) Connect the ground terminal of the power supply to the GND and the positive terminal to the VCC. Or connect the DC power to the connector (DC IN).
- 2) Turn on the power supply and pay attention to the supply current. If the current exceeds 400mA, please check for circuit fault.
- 3) Press Level- or Level+ button to change current of white LEDs. The intensity of LEDs will be in 1 level (highest) when power on.
- 4) The button (SD/EN) controls the IS31BL3212 Shutdown or Enable. When power on the IS31BL3212 is Enable and the LED (D20) is on.

EVALUATION BOARD OPERATION

The IS31BL3212 evaluation board performs constant output current with Pulse Count Control (PCC wire) serial interface. The interface records rising edges of the EN/SET pin and decodes them into 16 different states.

The evaluation board uses a MCU generating Pulse signal at EN/SET pin adjusting the LEDs current. There are 16 blue LEDs (D4~D19) above the buttons showing the intensity level.

Note: IS31BL3212 solely controls the white LEDs function on the evaluation board.

SOFTWARE SUPPORT

Please refer to the integrated program.

JP1 default is set to close circuit. If it is set to open, the onboard MCU will stop working. The MCU pin to drive the EN/SET pin will set to High Impedance. An external driving signal can be connected to the TP3 connecting point to control the IS31BL3212 LED driver.

Refer to the datasheet for more information about how to control the IS31BL3212 LED driver.

IS31BL3212 3-CHANNEL CONSTANT CURRENT LED DRIVER

ORDERING INFORMATION

Part No.	Temperature Range	Package
IS31BL3212-STLS2-EB	-40°C ~ +85°C (Industrial)	SOT-6, Lead-free

Table1: Ordering Information

For pricing, delivery, and ordering information, please contact Lumissil's analog marketing team at analog@Lumissil.com or (408) 969-6600.

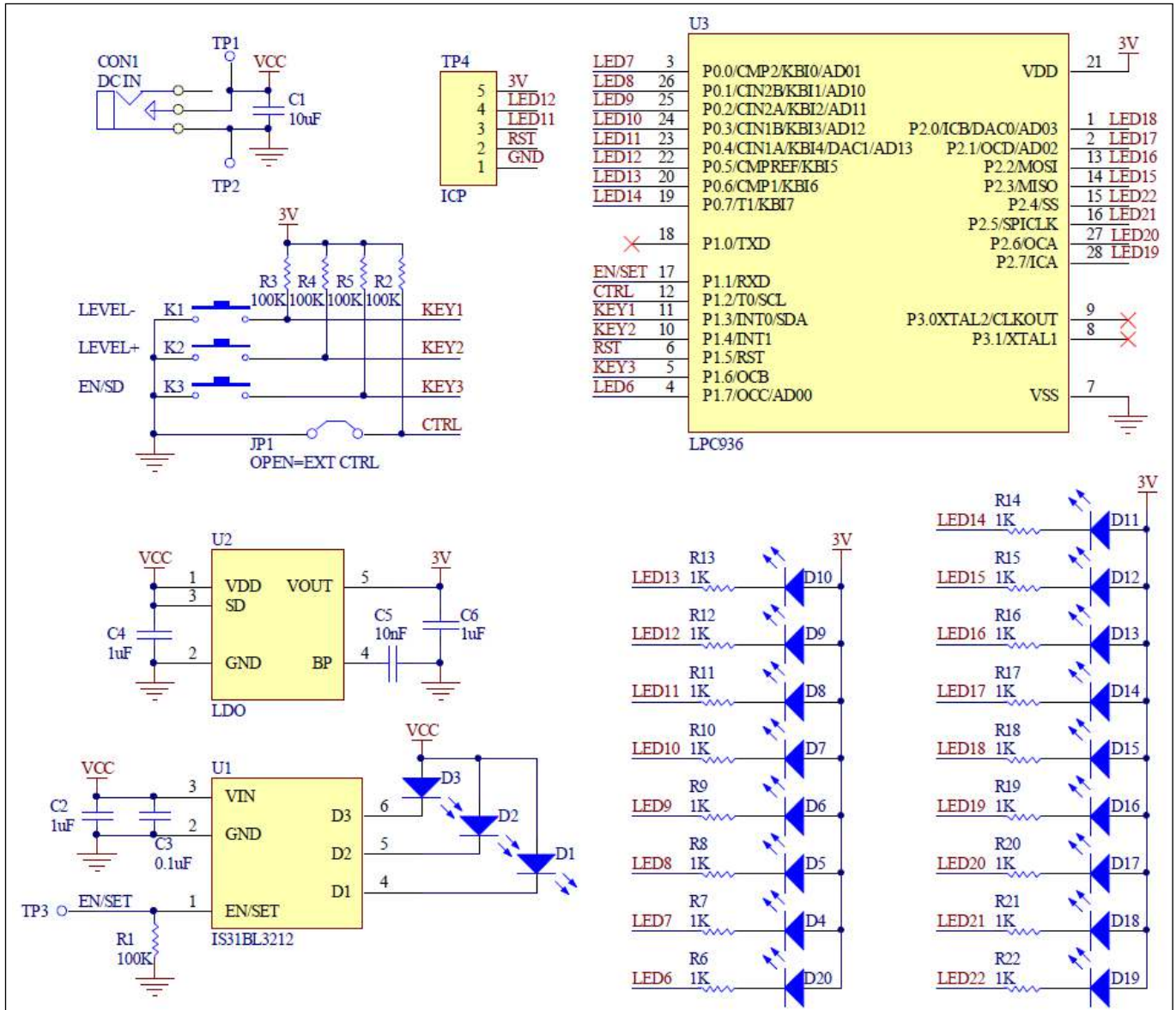

Figure 2: IS31BL3212 Application Schematic

IS31BL3212 3-CHANNEL CONSTANT CURRENT LED DRIVER

BILL OF MATERIALS

Name	Symbol	Description	Qty	Supplier	Part No.
LED Driver	U1	3 channels LED Driver	1	Lumissil	IS31BL3212
LDO	U2	Low-dropout Regulator	1	PAM	PAM3101
MCU	U3	Microcontroller	1	NXP	LPC936
LED Blue	D4~D20	Diode, LED Blue, SMD	17	Everlight	19-217/BHCZL1M2RY/3T
LED White	D1~D3	Diode, LED White, SMD	3	Everlight	EHP-C04/UT01-P01/TR
Resistor	R1~R5	RES,100k,1/16W,±5%,SMD	5		
Resistor	R6~R22	RES,1k,1/16W,±5%,SMD	17		
Capacitor	C1	CAP,10µF,16V,±20%,SMD	1		
Capacitor	C2,C4,C6	CAP,1µF,16V,±20%,SMD	3		
Capacitor	C3	CAP,0.1µF,16V,±20%,SMD	1		
Capacitor	C5	CAP,10nF,16V,±20%,SMD	1		
Buttons	K1~K3	Buttons SMD	3		

Bill of materials, refer to Figure 2 above.

IS31BL3212 3-CHANNEL CONSTANT CURRENT LED DRIVER

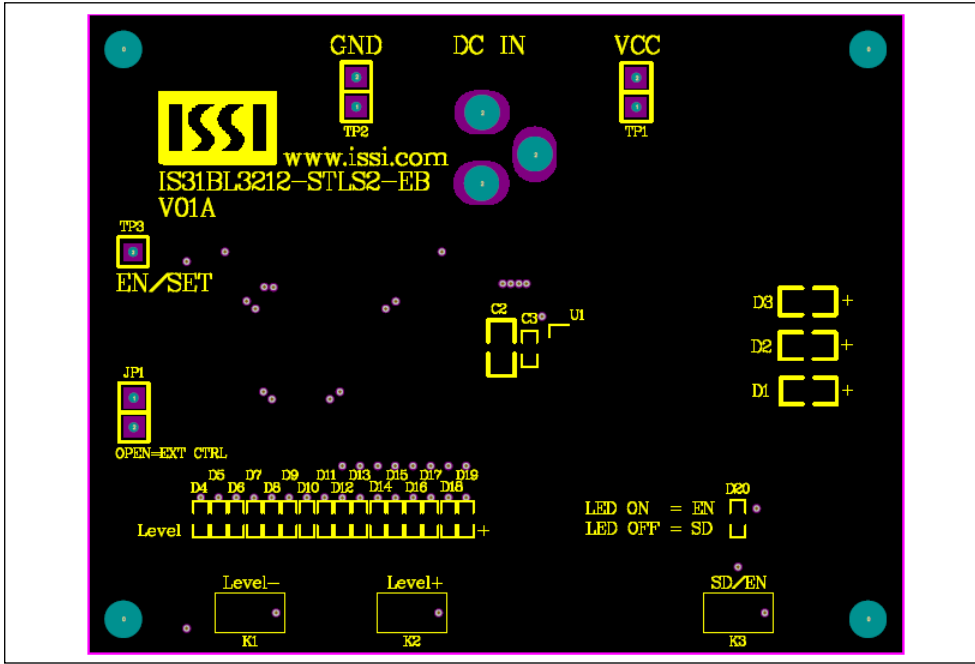

Figure 3: Board Component Placement Guide -Top Layer

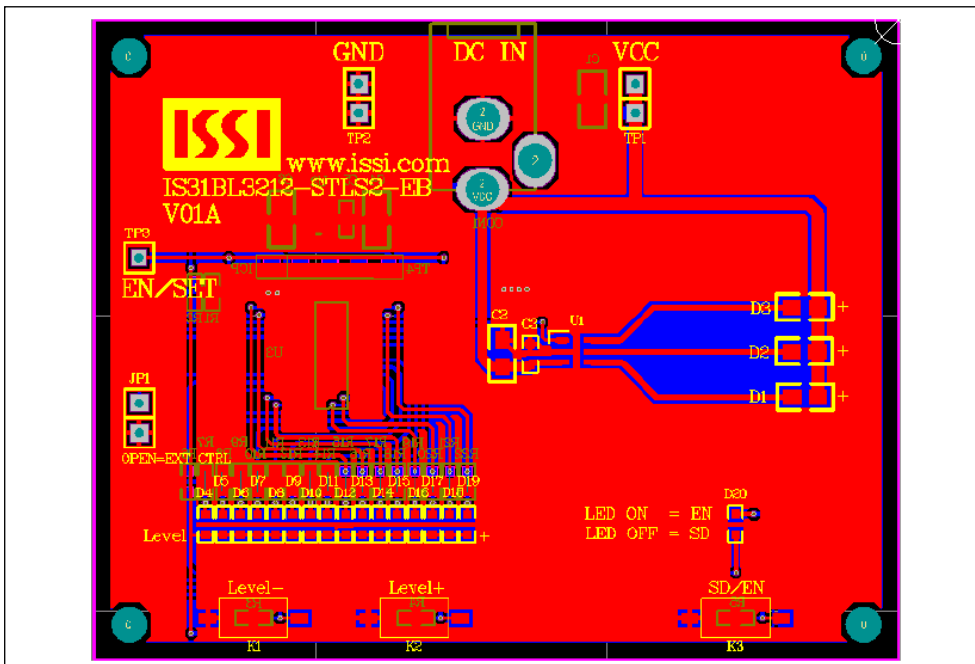

Figure 4: Board PCB Layout- Top Layer

IS31BL3212 3-CHANNEL CONSTANT CURRENT LED DRIVER

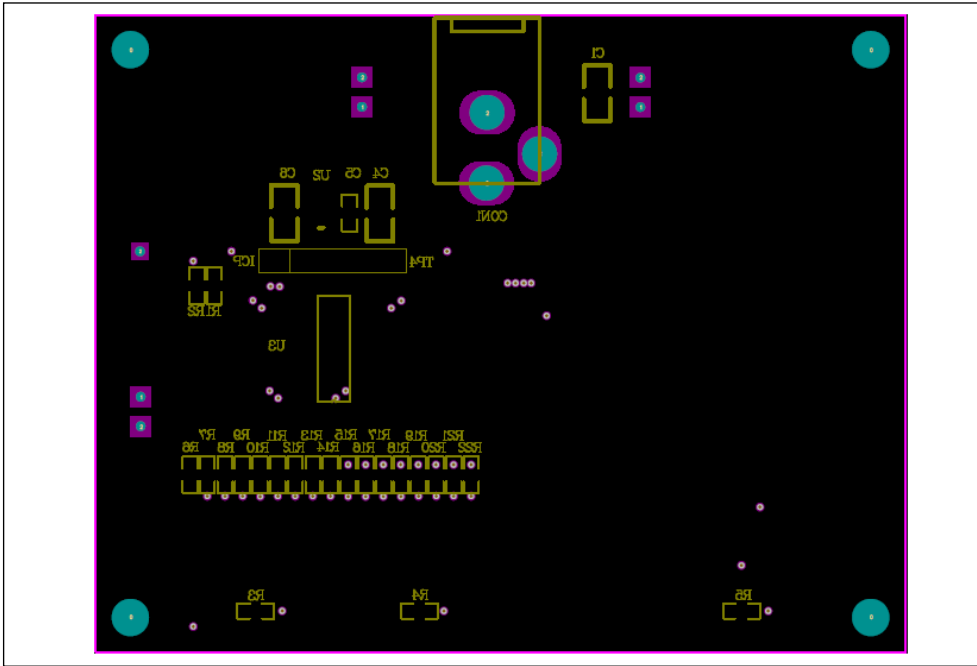

Figure 5: Board Component Placement Guide -Bottom Layer

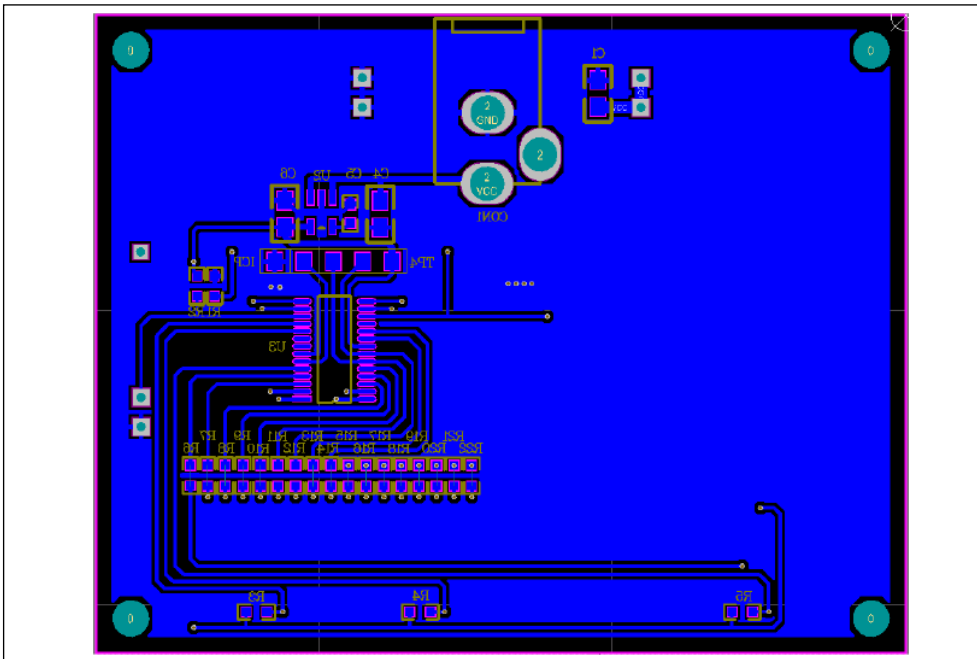

Figure 6: Board PCB Layout-Bottom Layer

Copyright © 2012 Lumissil Microsystems. All rights reserved. Lumissil Microsystems reserves the right to make changes to this specification and its products at any time without notice. Lumissil Microsystems assumes no liability arising out of the application or use of any information, products or services described herein. Customers are advised to obtain the latest version of this device specification before relying on any published information and before placing orders for products.

Lumissil Microsystems does not recommend the use of any of its products in life support applications where the failure or malfunction of the product can reasonably be expected to cause failure of the life support system or to significantly affect its safety or effectiveness. Products are not authorized for use in such applications unless Lumissil Microsystems receives written assurance to its satisfaction, that:

- a.) the risk of injury or damage has been minimized;
- b.) the user assume all such risks; and
- c.) potential liability of Lumissil Microsystems is adequately protected under the circumstances