

KEY FEATURES

- SMPTE 292M compliant
- standards detection/indication for SMPTE 292M levels A/B,C,D/E,F,G/H,I,J/K,L/M
- NRZI decoding and SMPTE descrambling with BYPASS option
- line CRC calculation, comparison
- selectable line based CRC re-insertion
- H, V, F timing reference signal (TRS) extraction
- selectable flywheel for noise immune H, V, F extraction
- selectable automatic switch line handling
- selectable TRS and line number re-insertion
- selectable active picture illegal code re-mapping
- ANC data position indication
- ANC data extraction via internal FIFOs (1024 bytes on Y and C channels)
- configurable FIFO LOAD pulse
- Pb-free and Green
- 20 bit 3.3V CMOS input data bus
- optimized input interface to GS1545 or GS1540
- single +3.3V power supply
- 5V tolerant I/O

APPLICATIONS

- SMPTE 292M Serial Digital Interfaces

DESCRIPTION

When interfaced to the Genum GS1545 HDTV Equalizing Receiver or GS1540 Non-Equalizing Receiver, the GS1500 performs the final conversion to word aligned data. The device performs NRZI decoding and de-scrambling as per SMPTE 292M and word-aligns to the incoming data stream. Line based CRCs are calculated on the incoming data stream and are compared against the CRCs embedded within the data stream.

HVF timing information is extracted from the data stream. A selectable internal HVF flywheel provides superior noise immunity against TRS signal errors. The device also detects and indicates the input video signal standard.

The GS1500 can detect and re-map illegal code words contained within the active portion of the video signal. The positions of the embedded ANC data are indicated and the ANC data may be extracted and accessed by the user through an internal FIFO interface. Prior to exiting the device, TRS, Line Numbers and CRCs based on internal calculations may be re-inserted into the data stream.

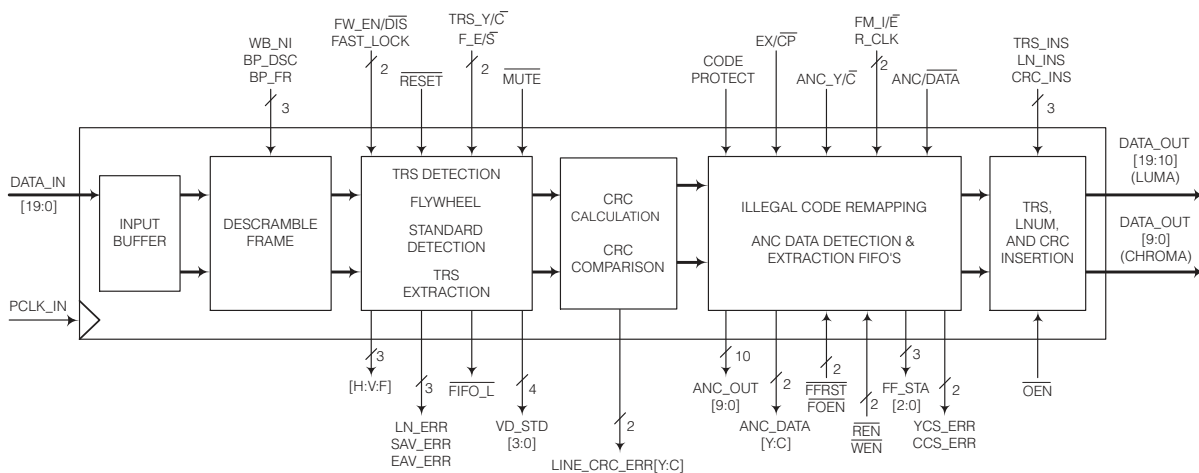

GS1500 FUNCTIONAL BLOCK DIAGRAM

TABLE OF CONTENTS

1. PIN OUT	3
1.1 PIN ASSIGNMENT	3
1.2 PIN DESCRIPTIONS	4-8
2. ELECTRICAL CHARACTERISTICS	9
2.1 ABSOLUTE MAXIMUM RATINGS	9
2.2 DC ELECTRICAL CHARACTERISTICS	9
2.3 AC ELECTRICAL CHARACTERISTICS	9
3. DETAILED DESCRIPTION	10-17
4. REFERENCES	18
5. PACKAGE & ORDERING INFORMATION	18
5.1 PACKAGE DIMENSIONS	18
5.2 ORDERING INFORMATION	18

1. PIN OUT

1.1 PIN ASSIGNMENT

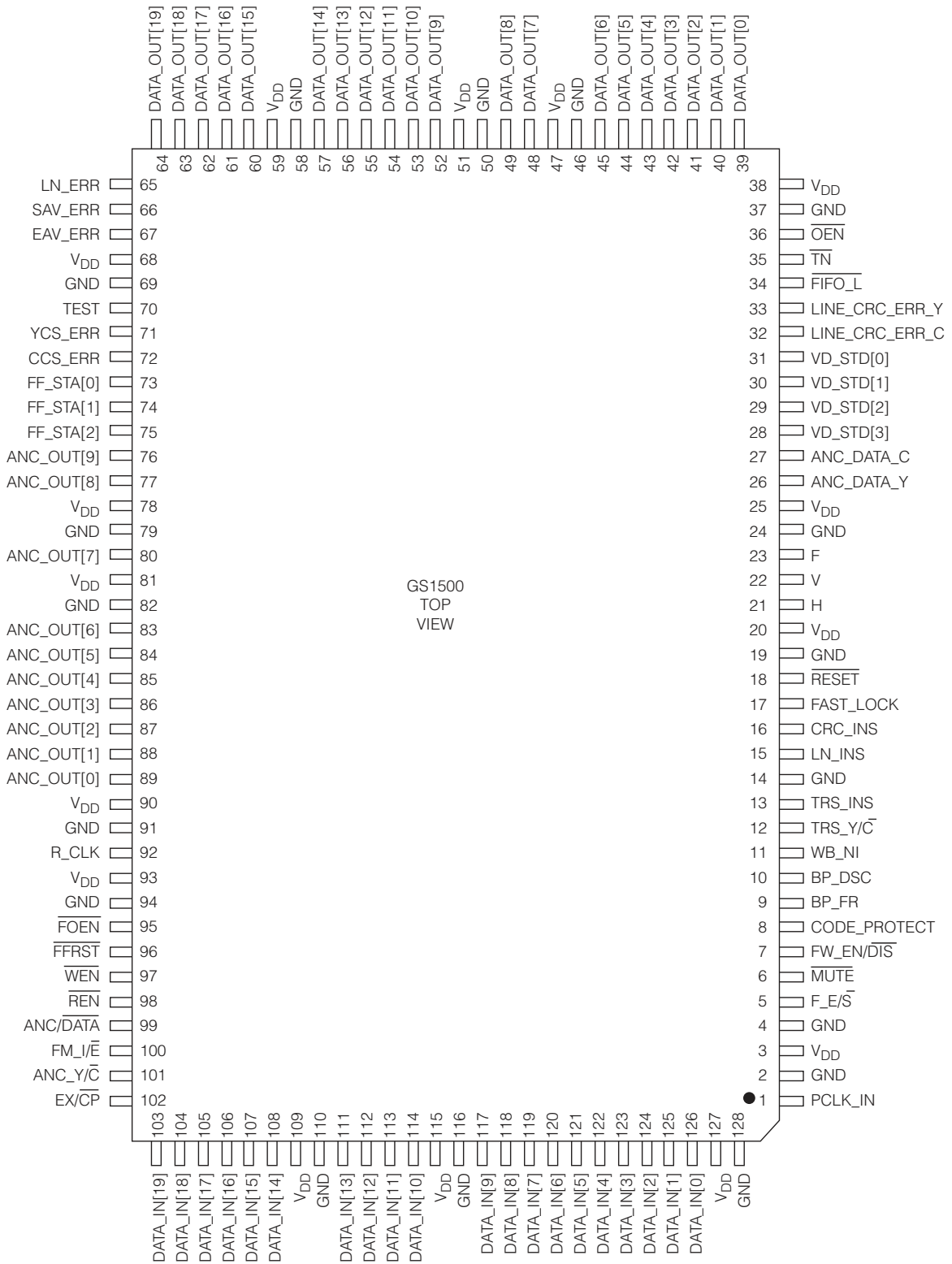

1.2 PIN DESCRIPTIONS

PIN NUMBER	NAME	TIMING	TYPE	DESCRIPTION
1	PCLK_IN	Synchronous wrt PCLK_IN	Input	Input Clock. The device uses PCLK_IN for clocking the input data stream into DATA_IN[19:0]. This clock is generated by the GS1545 or GS1540.
2, 4, 14, 19, 24, 37, 46, 50, 58, 69, 79, 82, 91, 94, 110, 116, 128	GND		GND	Ground power supply connections.
3, 20, 25, 38, 47, 51, 59, 68, 78, 81, 90, 93, 109, 115, 127	V _{DD}		Power	Positive power supply connections.
5	F_E \bar{S}	Non-synchronous	Input	Control Signal Input. Used to control where the $\overline{FIFO_L}$ signal is generated. When F_E \bar{S} is high, the GS1500 generates $\overline{FIFO_L}$ signal at EAV. When F_E \bar{S} is low, the GS1500 generates $\overline{FIFO_L}$ signal at SAV. See Fig. 4 for timing information.
6	\overline{MUTE}	Synchronous wrt PCLK_IN	Input	Control Signal Input. Used to enable or disable blanking of the LUMA (DATA_OUT[19:10]) and CHROMA (DATA_OUT[9:0]). When \overline{MUTE} is low, the device sets the accompanying LUMA and CHROMA data to their appropriate blanking levels. When \overline{MUTE} is high, the LUMA and CHROMA data streams pass through this stage of the device unaltered.
7	FW_EN/ \overline{DIS}	Non-synchronous	Input	Control Signal Input. Used to enable or disable the internal flywheel. When FW_EN/ \overline{DIS} is high, the internal flywheel is enabled. When FW_EN/ \overline{DIS} is low, the internal fly-wheel is disabled.
8	CODE_PROTECT	Non-synchronous	Input	Control Signal Input. Used to enable or disable re-mapping of out-of-range words contained in the active portion of the video signal. When this signal is high, the device re-maps out-of-range words contained within the active portion of the video signal into CCIR-601 compliant words. Values between 000-003 are re-mapped to 004. Values between 3FC and 3FF are re-mapped to 3FB. When this signal is low, out-of-range words in the active video region pass through the device unaltered.
9	BP_FR	Non-synchronous	Input	Control Signal Input. Used to enable or disable word boundary framing. When BP_FR is low, internal framing is enabled. When BP_FR is high, internal framing is bypassed.
10	BP_DSC	Non-synchronous	Input	Control Signal Input. Used to enable or disable the SMPTE 292M descrambler. When BP_DSC is low, the internal SMPTE 292M descrambler is enabled. When BP_DSC is high, the internal SMPTE 292M de-scrambler is bypassed.
11	WB_NI	Non-synchronous	Input	Control Signal Input. Used to enable or disable noise immune operation of the word boundary framer. When WB_NI is high, noise-immune word boundary alignment is enabled. The device switches to a new word boundary only when it has detected two consecutive identical new TRS positions. When WB_NI is low, the device re-aligns the word boundary position at every instance of a TRS.
12	TRS_Y/ \bar{C}	Non-synchronous	Input	Control Signal Input. Used to control whether LUMA or CHROMA TRS ID's are detected and used. When TRS_Y/ \bar{C} is high, the device detects and uses TRS signals embedded in the LUMA channel. When TRS_Y/ \bar{C} is low, the device detects and uses TRS signals embedded in the CHROMA channel.

1.2 PIN DESCRIPTIONS (Continued)

PIN NUMBER	NAME	TIMING	TYPE	DESCRIPTION
13	TRS_INS	Non-synchronous	Input	Control Signal Input. Used to enable or disable re-insertion of the TRS into the data stream. When TRS_INS is high, the device re-inserts TRS into the incoming data stream based on the internal calculation. The original TRS packets are set to the blanking levels. If the flywheel is enabled, TRS calculated by the flywheel is used for insertion. When TRS_INS is low, the device will not re-insert TRS even if errors in TRS signals are detected.
15	LN_INS	Non-synchronous	Input	Control Signal Input. Used to enable or disable re-insertion of the line number into the data stream. When LN_INS is high, the device re-inserts the line number into the incoming data stream based on the internal calculation. The original line number packets are set to the blanking levels. If the flywheel is enabled, the line number calculated by the flywheel is used for insertion. When LN_INS is low, the device will not re-insert the line number.
16	CRC_INS	Non-synchronous	Input	Control Signal Input. Used to enable or disable re-insertion of the CRC into the data stream. When CRC_INS is high, the device is enabled to re-insert line CRCs based on the internal calculation. When CRC_INS is low, the device will not re-insert the CRCs.
17	FAST_LOCK	Synchronous wrt PCLK_IN	Input	Control Signal Input. Used to control the flywheel synchronization when a switch line occurs. When a low to high transition occurs on the FAST_LOCK signal, the internal flywheel will immediately re-synchronize to the next valid EAV or SAV TRS in the incoming data stream. See Fig. 5 for timing information.
18	$\overline{\text{RESET}}$	Non-synchronous	Input	Control Signal Input. Used to reset the system state registers to their default 720p parameters. When $\overline{\text{RESET}}$ is high, the fly wheel, TRS Detection, and ANC Detection operate normally. When $\overline{\text{RESET}}$ is low, the flywheel, TRS Detection, and ANC Detection are reset to the 720p parameters after a rising edge on PCLK_IN. The read and write counters are not affected.
21	H	Synchronous wrt PCLK_IN	Output	Control Signal Output. This signal indicates the Horizontal blanking period of the video signal. Refer to Fig. 2 for timing information of H relative to DATA_OUT[19:10] and DATA_OUT[9:0], LUMA and CHROMA respectively.
22	V	Synchronous wrt PCLK_IN	Output	Control Signal Output. This signal indicates the Vertical blanking period of the video signal. Refer to Fig. 2 for timing information of V relative to DATA_OUT[19:10] and DATA_OUT[9:0], LUMA and CHROMA respectively.
23	F	Synchronous wrt PCLK_IN	Output	Control Signal Output. This signal indicates the ODD/EVEN field of the video signal. Refer to Fig. 2 for timing information of F relative to DATA_OUT[19:10] and DATA_OUT[9:0], LUMA and CHROMA respectively. When locked and the input signal is of a progressive scan nature, F stays low at all times.
26	ANC_DATA_Y	Synchronous wrt PCLK_IN	Output	Control Signal Output. This signal indicates the position of the embedded ANC data in the outgoing LUMA (DATA_OUT [19:10]) data stream. ANC_DATA_Y goes high for the entire time that an ANC_DATA packet is present in the LUMA (DATA_OUT[19:10]) data stream whether it be in the active video area or the ANC area. Refer to Fig. 17 for timing of ANC_DATA_Y relative to LUMA (DATA_OUT[19:10]). During detection of ANC data, any errors in the data count (DC) packet will consequently cause errors in the duration of the flags. Bit errors in an ANC header will prevent the packet from being detected.

1.2 PIN DESCRIPTIONS (Continued)

PIN NUMBER	NAME	TIMING	TYPE	DESCRIPTION
27	ANC_DATA_C	Synchronous wrt PCLK_IN	Output	Control Signal Output. This signal indicates the position of the embedded ANC data in the outgoing CHROMA (DATA_OUT[9:0]) data stream. ANC_DATA_C goes high for the entire time that an ANC_DATA packet is present in the CHROMA (DATA_OUT[9:0]) data stream whether it be in the active video area or the HANC area. Refer to Fig. 17 for timing of ANC_DATA_C relative to CHROMA (DATA_OUT[9:0]). During detection of ANC data, any errors in the data count (DC) packet will consequently cause errors in the duration of the flags. Bit errors in an ANC header will prevent the packet from being detected.
28, 29, 30, 31	VD_STD[3:0]	Synchronous wrt PCLK_IN	Output	Control Signal Output. VD_STD[3:0] indicates which input video standard the device has detected. The GS1500 will indicate all of the formats in SMPTE292M (see Table 3) plus it will indicate an unknown interlace or progressive scan format.
32	LINE_CRC_ERR_C	Synchronous wrt PCLK_IN	Output	Status Signal Output. Indicates a difference in the calculated versus embedded CRC in the CHROMA channel. When LINE_CRC_ERR_C is high, it indicates that the GS1500 has detected a difference between the line based CRCs it calculates for the CHROMA channel and the line based CRCs embedded within the CHROMA channel. When LINE_CRC_ERR_C is low, the embedded and calculated CRC's match. Refer to Fig. 19 for timing information of LINE_CRC_ERR_C.
33	LINE_CRC_ERR_Y	Synchronous wrt PCLK_IN	Output	Status Signal Output. Indicates a difference in the calculated versus embedded CRC in the LUMA channel. When LINE_CRC_ERR_Y is high, it indicates that the GS1500 has detected a difference between the line based CRCs it calculates for the LUMA channel and the line based CRCs embedded within the LUMA channel. When LINE_CRC_ERR_Y is low, the embedded and calculated CRC's match. Refer to Fig. 19 for timing information of LINE_CRC_ERR_Y.
34	$\overline{\text{FIFO_L}}$	Synchronous wrt PCLK_IN	Output	Control Signal Output. Used to control an external FIFO(s). $\overline{\text{FIFO_L}}$ is normally high, but is set low for the EAV or SAV word depending on the state of F_E/S. Refer to Fig. 4 for timing information of $\overline{\text{FIFO_L}}$ relative to LUMA (DATA_OUT[19:10]) and CHROMA (DATA_OUT[9:0]).
35	$\overline{\text{TN}}$		TEST	Test Pin. Used for test purposes only. This pin must be connected to V _{DD} for normal operation
36	$\overline{\text{OEN}}$	Non-synchronous	Input	Control Signal Input. Used to enable the DATA_OUT[19:0] output bus or set it in a high Z state. When $\overline{\text{OEN}}$ is low, the LUMA (DATA_OUT[19:10]) and CHROMA (DATA_OUT [9:0]) busses are enabled. When $\overline{\text{OEN}}$ is high, these busses are in a high Z state.
52, 49, 48, 45, 44, 43, 42, 41, 40, 39	DATA_OUT[9:0] (CHROMA channel)	Synchronous wrt PCLK_IN	Output	CHROMA Output Data Bus. DATA_OUT [9] is CHROMA_OUT[9] which is the MSB of the CHROMA output signal (pin 52). DATA_OUT [0] is CHROMA_OUT[0] which is the LSB of the CHROMA output signal (pin 39).
64, 63, 62, 61, 60, 57, 56, 55, 54, 53	DATA_OUT[19:10] (LUMA channel)	Synchronous wrt PCLK_IN	Output	LUMA Output Data Bus. DATA_OUT [19] is LUMA_OUT[9] which is the MSB of the LUMA output signal. (pin 64) DATA_OUT [10] is LUMA_OUT[0] which is the LSB of the LUMA output signal (pin 53).

1.2 PIN DESCRIPTIONS (Continued)

PIN NUMBER	NAME	TIMING	TYPE	DESCRIPTION
65	LN_ERR	Synchronous wrt PCLK_IN	Output	Status Signal Output. Used to indicate a Line Number error or a mismatch between the embedded line number and the flywheel line number when the flywheel is enabled. When LN_ERR is high, a line number error is detected or the internal flywheel indicates mismatching line numbers. Refer to Fig. 3 for timing information of LN_ERR relative to LUMA (DATA_OUT[19:10]) and CHROMA (DATA_OUT [9:0]). Since LN_ERR depends on the sequence of line numbers, a line number error will actually cause LN_ERR to go high for two lines.
66	SAV_ERR	Synchronous wrt PCLK_IN	Output	Status Signal Output. Indicates a TRS error or a mismatch between the embedded TRS and the flywheel TRS when the flywheel is enabled. This signal is set high when an error in the SAV TRS is detected or when the internal flywheel indicates there is a mismatching SAV TRS. Refer to Fig. 3 for timing information of SAV_ERR relative to LUMA (DATA_OUT[19:10]) and CHROMA (DATA_OUT [9:0]).
67	EAV_ERR	Synchronous wrt PCLK_IN	Output	Status Signal Output. Indicates a TRS error or a mismatch between the embedded TRS and the flywheel TRS when the flywheel is enabled. This signal is set high when an error in the EAV TRS is detected or when the internal flywheel indicates there is a mismatching EAV TRS. Refer to Fig. 3 for timing information of EAV_ERR relative to LUMA (DATA_OUT[19:10]) and CHROMA (DATA_OUT [9:0]).
70	TEST		TEST	Test Pin. Used for test purposes only. This pin must be connected to GND for normal operation.
71	YCS_ERR	Synchronous wrt PCLK_IN	Output	Status Signal Output. Indicates a checksum error or a mismatch between the embedded checksum and the calculated checksum for the LUMA (DATA_OUT[19:10]) channel. When YCS_ERR is high, an error in the checksum is detected. Refer to Fig. 18 for timing information of YCS_ERR relative to LUMA (DATA_OUT[19:10]).
72	CCS_ERR	Synchronous wrt PCLK_IN	Output	Status Signal Output. Indicates a checksum error or a mismatch between the embedded checksum and the calculated checksum for the CHROMA (DATA_OUT[9:0]) channel. When CCS_ERR is high, an error in the checksum is detected. Refer to Fig. 18 for timing information of CCS_ERR relative to CHROMA (DATA_OUT [9:0]).
75, 74, 73	FF_STA[2:0]		Output	Control Signal Output. FF_STA[2:0] is the FIFO status output to indicate the content level of the internal FIFOs. FF_STA[2:0]=000: Error flag, FIFO is under run . FF_STA[2:0]=001: FIFO is empty. FF_STA[2:0]=010: FIFO is almost empty; 32 bytes filled FF_STA[2:0]=011: FIFO is ready. FF_STA[2:0]=100: FIFO is half full. FF_STA[2:0]=101: FIFO is almost full; 992 bytes filled FF_STA[2:0]=110: FIFO is full. FF_STA[2:0]=111: Error flag, FIFO is over run. When ANC_Y/C is high, FF_STA[2:0] indicates the status of the LUMA ANC data FIFO. When ANC_Y/C is low, FF_STA[2:0] indicates the status of the CHROMA ANC data FIFO. See Fig. 6 to Fig. 15 for timing information.
76, 77, 80, 83, 84, 85, 86, 87, 88, 89	ANC_OUT[9:0]	Synchronous wrt PCLK_IN	Output	ANC Data Output Bus. ANC_OUT[9] is the MSB and ANC_OUT[0] is the LSB. When ANC_Y/C is high, ANC_OUT[9:0] presents ANC data from the LUMA FIFO. When ANC_Y/C is low, ANC_OUT[9:0] presents ANC data from the CHROMA FIFO.

1.2 PIN DESCRIPTIONS (Continued)

PIN NUMBER	NAME	TIMING	TYPE	DESCRIPTION
92	R_CLK	N/A	Input	Input Clock Signal. Used to read information from the internal FIFO(s). On the rising edge of R_CLK, the device will extract the next word from the internal LUMA/CHROMA channel data FIFO, depending on the status of the ANC_Y/C signal.
95	$\overline{\text{FOEN}}$	Non-synchronous	Input	Control Signal Input. Used to enable or disable the internal FIFO outputs. When $\overline{\text{FOEN}}$ is low, the FIFO ANC_OUT[9:0] and FF_STA[2:0] are enabled. When $\overline{\text{FOEN}}$ is high, the FIFO ANC_OUT[9:0] and FF_STA[2:0] outputs are in a high Z state. Note that the internal read address pointers are updated independently of $\overline{\text{FOEN}}$.
96	$\overline{\text{FFRST}}$	Synchronous wrt PCLK_IN	Input	Control Signal Input. $\overline{\text{FFRST}}$ is used to supply synchronous reset signals to the FIFO. When $\overline{\text{FFRST}}$ is low, the FIFO is reset and all internal read and write address pointers are set to their starting locations.
97	$\overline{\text{WEN}}$	Synchronous wrt PCLK_IN	Input	Control Signal Input. Used to enable or disable extracting data into the internal FIFO. When $\overline{\text{WEN}}$ is low, extracting data into the internal FIFO is enabled. When $\overline{\text{WEN}}$ is high, extracting data into the internal FIFO is disabled.
98	$\overline{\text{REN}}$	Synchronous wrt R_CLK	Input	Control Signal Input. Used to enable or disable reading data from the internal FIFO. When $\overline{\text{REN}}$ is low, reading from the internal FIFO is enabled. When $\overline{\text{REN}}$ is high, reading from the internal FIFO is disabled.
99	ANC/ $\overline{\text{DATA}}$	Non-synchronous	Input	Control Signal Input. Used to control copying of ANC data packets into the internal FIFOs. When ANC/ $\overline{\text{DATA}}$ is high, the device extracts/copies only ANC data packets into the internal FIFO buffers. When ANC/ $\overline{\text{DATA}}$ is low, the device extracts/copies all data words within the horizontal blanking period regardless of their status (i.e. ANC data or not) and places these words into the internal FIFO buffers.
100	FM_I/ $\overline{\text{E}}$	Non-synchronous	Input	Control Signal Input. When FM_I/ $\overline{\text{E}}$ is high, the device operates in a mode where the FIFO reset and write enable signals are generated internally. In this mode, the device limits the data extraction to the HANC region of the video stream. The extracted ANC data are to be accessed during the active video period using $\overline{\text{REN}}$. When FM_I/ $\overline{\text{E}}$ is low, the device operates in another mode where the FIFO reset and write enable signals are generated externally by the user and supplied to the device via the $\overline{\text{FFRST}}$ and $\overline{\text{WEN}}$ control signal inputs.
101	ANC_Y/ $\overline{\text{C}}$	Synchronous wrt PCLK_IN	Input	Control Signal Input. Used to control extraction of ANC data from the video data stream into the LUMA or CHROMA FIFO. When ANC_Y/ $\overline{\text{C}}$ is high, data is extracted from the luma data stream into the internal LUMA FIFO. When ANC_Y/ $\overline{\text{C}}$ is low, data is extracted from the chroma data stream into the internal CHROMA FIFO.
102	EX/ $\overline{\text{CP}}$	Non-synchronous	Input	Control Signal Input. Used to control if the ANC Data is extracted or copied into the internal FIFO buffers. When EX/ $\overline{\text{CP}}$ is high, the device extracts ANC data from the incoming data stream into the internal FIFO buffers and replaces any extracted words with appropriate blanking levels. When EX/ $\overline{\text{CP}}$ is low, the device makes a copy of ANC data from the incoming data stream into the internal FIFO buffers.
103, 104, 105, 106, 107, 108, 111, 112, 113, 114, 117, 118, 119, 120, 121, 122, 123, 124, 125, 126	DATA_IN [19:0]	Synchronous wrt PCLK_IN	Input	Input Data Bus. DATA_IN [19] is the MSB of the signal (pin 103). DATA_IN [0] is the LSB of the signal (pin 126). This data is typically scrambled and not word aligned.

2. ELECTRICAL CHARACTERISTICS

2.1 ABSOLUTE MAXIMUM RATINGS

PARAMETER	VALUE
Supply Voltage	-0.5V to +4.6V
Input Voltage Range (any input)	$-0.5V < V_{IN} < 5.5V$
Operating Temperature Range	$0^{\circ}C \leq T_A \leq 70^{\circ}C$
Storage Temperature Range	$-40^{\circ}C \leq T_S \leq 125^{\circ}C$
Lead Temperature (soldering 10 seconds)	260°C

2.2 DC ELECTRICAL CHARACTERISTICS

$V_{DD} = 0.3$ to $3.6V$, $T_A = 0^{\circ}C$ to $70^{\circ}C$, unless otherwise shown

PARAMETER	SYMBOL	CONDITIONS	MIN	TYP	MAX	UNITS	NOTES
Positive Supply Voltage	V_{DD}		3.0	3.3	3.6	V	
Supply Current	I_{DD}	$f = 74.25MHz$, $T_A = 25^{\circ}C$	-	413	480	mA	
Input Logic LOW Voltage	V_{IL}	$I_{LEAKAGE} < 10\mu A$	-	-	0.8	V	
Input Logic HIGH Voltage	V_{IH}	$I_{LEAKAGE} < 10\mu A$	2.1	3.3	5.0	V	
Output Logic LOW Voltage	V_{OL}	$V_{DD} = 3.0$ to $3.6V$, $I_{OL} = 4mA$	-	0.3	0.4	V	
Output Logic HIGH Voltage	V_{OH}	$V_{DD} = 3.0$ to $3.6V$, $I_{OH} = -4mA$	2.6	-	-	V	

2.3 AC ELECTRICAL CHARACTERISTICS

$V_{DD} = 0.3$ to $3.6V$, $T_A = 0^{\circ}C$ to $70^{\circ}C$, unless otherwise shown

PARAMETER	SYMBOL	CONDITIONS	MIN	TYP	MAX	UNITS	NOTES
Clock Input Frequency	f_{HSCI}		-	74.25	80	MHz	Also supports 74.25/ 1.001MHz
Input Data Setup Time	t_{SU}		2.5	-	-	ns	50% levels
Input Data Hold Time	t_{IH}		1.5	-	-	ns	50% levels
Input Clock Duty Cycle			40	-	60	%	
Output Data Hold Time	t_{OH}	With 15pF load	2.0	-	-	ns	Note 3
Output Enable Time	t_{OEN}	With 15pF load	-	-	8	ns	
Output Disable Time	t_{ODIS}	With 15pF load	-	-	10	ns	
Output Data Delay Time	t_{OD}	With 15pF load	-	-	10	ns	Note 2
Output Data Rise/Fall Time	t_{ROD}/t_{FOD}	With 15pF load	-	-	2.75	ns	20% to 80% levels
FIFO Input Data Setup Time	t_{FSU}		8.0	-	-	ns	Note 1
FIFO Input Data Hold Time	t_{FIH}		4.0	-	-	ns	Note 1

NOTES:

1. The following signals need to adhere to this timing: $\overline{ANC_Y/C}$, \overline{REN} , \overline{WEN} , \overline{FFRST}
2. Timing of the $FF_STA[2:0]$ outputs may be greater than specified.
3. Output timing characteristics also apply to FIFO outputs.

3. DETAILED DESCRIPTION

3.1 DATA INPUT AND OUTPUTS

Data enters and exits the device on the rising edge of PCLK_IN as shown in Figures 1 and 2. This data can be scrambled or unscrambled and framed or unframed.

3.2 DESCRAMBLER AND FRAMER

Both the descrambler and framer can be enabled or disabled independently to allow the input to remain scrambled or unscrambled. If the data is unscrambled, it can be word aligned (framed) or pass through unaltered.

3.3 STANDARDS INDICATION

VD_STD[3:0] indicates the standard that the device has detected. The states of VD_STD[3:0] are shown Tables 1 and 2.

TABLE 1: Progressive Scan Standards Indication (VD_STD[3]=0)

VD_STD[3:0]	DESCRIPTION
0000	720p (60 & 60/1.001Hz → L/M) [SMPTE296M]
0001	Reserved
0010	1080p (30 & 30/1.001Hz → G/H) [SMPTE274M]
0011	Reserved
0100	1080p (25Hz → I) [SMPTE274M]
0101	Reserved
0110	1080p (24 & 24/1.001Hz → J/K) [SMPTE274M]
0111	Unknown Progressive with F = 0 always.

TABLE 2: Interlaced Standards Indication (VD_STD[3]=1)

VD_STD[3:0]	DESCRIPTION
1000	1080i (30 & 30/1.001Hz → D/E) [SMPTE274M]
1001	Reserved
1010	1080i (25Hz → F) [SMPTE274M]
1011	Reserved
1100	1080i (25Hz → C) [SMPTE295M]
1101	Reserved
1110	1035i (30 & 30/1.001Hz → A/B) [SMPTE260M]
1111	Unknown Interlaced with F switching 0/1

Note the following in the above Standards Indication Tables:

- SMPTE260M is 1125 lines/frame
- SMPTE274M is 1125 lines/frame
- SMPTE295M is 1250 lines/frame
- SMPTE296M is 750 lines/frame

See Table 3 for more details on the source format parameters.

3.4 FLY WHEEL OPERATION

The flywheel logic checks the incoming video data for valid video lines. If the incoming data represents a valid line, the flywheel remains in sync with the incoming data. If the incoming data represents an invalid line, the flywheel uses the stored timing information for the past valid line to generate the output HVF timing signals. When three consecutive lines having identical timing are detected, this new timing information is saved and the flywheel operation is updated to this new timing. Mismatches between the HVF information decoded from the data stream and that indicated by the flywheel will trigger the EAV_ERR and SAV_ERR signals as shown in Figure 3. HVF output timing is shown in Figure 2.

3.5 AUTOMATIC SWITCH LINE LOCK HANDLING

The automatic switch line lock is based on the assumption that switching occurs between video sources of the same format. In other words, the switching of video sources causes only the H signal to be out of alignment whereas V and F signals remain in sync. Therefore, when in the automatic switch line lock mode (FAST_LOCK transitions for low to high), the flywheel positive H signal transition aligns with the detected positive H signal transition. Timing for the FAST_LOCK signal is shown in Figure 5.

3.6 FIFO

The device does not flag transmission errors which might exist in the ANC data packages. The internal FIFO is 1024 words deep for each of LUMA and CHROMA channels. For those formats where the HANC region is greater than 1024 words, the user must take steps to ensure the FIFO does not overflow, otherwise data may be lost. The GS1500 provides status signals to indicate the current content level of the internal FIFO buffers, as described in section 6.1.

3.6.1 FIFO Status Bits

The device provides status output signals FF_STA[2:0] that indicate the state of the current content level of the internal FIFO buffers. If the extracted ANC data have completely filled the internal FIFO buffer, FF_STA[2:0] outputs 110. When the internal FIFO is full, any attempt to write data into the FIFO will cause the FIFO to overrun. The device flags this overrun state by setting FF_STA[2:0]=111 and no more data will be extracted from the video stream.

If all ANC data in the FIFO is accessed by the user through the FIFO interface and the internal FIFO becomes empty, then FF_STA[2:0] outputs 001. When the internal FIFO is empty, any attempt to read data from the FIFO will cause the FIFO to under run. The device flags this under run state by setting FF_STA[2:0]=000.

When $\overline{\text{ANC_Y/C}}$ is high, FF_STA indicates the status of the LUMA FIFO buffer. When $\overline{\text{ANC_Y/C}}$ is low, FF_STA indicates the status of the CHROMA FIFO buffer.

The FIFO status flags must be up-to-date. Therefore, certain FIFO status flags are synchronized with respect to R_CLK , and others are synchronized with respect to PCLK_IN . During a write cycle, status flags controlled by R_CLK experience a three-cycle latency with respect to R_CLK . During a read cycle, status flags controlled by PCLK_IN experience a three-cycle latency with respect to PCLK_IN . See *Table 4 and Figures 6 to 15*.

NOTE: If a simultaneous FIFO read and write operation is to be performed, the $\text{FF_STA}[2:0]$ outputs should not be used as they may indicate incorrect FIFO status.

3.6.2 ANC/DATA Extraction

When the control signal $\overline{\text{ANC/DATA}}$ is high and $\overline{\text{WEN}}$ is low, the device detects the ANC data header and extracts the ANC data (including the header) when these data are present in the video streams. When $\overline{\text{ANC/DATA}}$ and $\overline{\text{WEN}}$ are both low, the device extracts all original video data into the FIFO. To ensure ANC data extraction from the LUMA or CHROMA channels, empty (unload) the ANC data from the respective FIFO buffer during the active video portion of the data streams. ANC data is extracted from a video stream and written into the corresponding internal FIFO buffer until it is completely full. When a FIFO buffer is full, the $\text{FF_STA}[2:0]$ signal is set to 110.

The device provides ANC data copying capability as an alternative to extraction. When $\overline{\text{EX/CP}}$ is high, the extraction function is enabled. The device replaces the extracted data in the video streams with their respective blanking levels. If $\overline{\text{EX/CP}}$ is low, the copy function is enabled. All the original data remain in the video stream after copying them into the FIFO buffer.

To extract ANC data from the HANC region only, the device provides an automated extraction mode. When the control signal $\overline{\text{FM_I/E}}$ is high, the FIFO control signals $\overline{\text{FFRST}}$ and $\overline{\text{WEN}}$ cannot be used.

In this mode of operation, the device generates reset and enable signals internally, which allows an automated extraction of ANC data from HANC region of the incoming LUMA and CHROMA data streams. The user must supply a proper $\overline{\text{REN}}$ signal to enable the access of ANC data stored in the FIFO. These data should be read out of the FIFO during the active video period. Once all words have been read from the FIFO, the FF_STA signal is set to 001. If the user has not emptied the FIFO by the time the next HANC period begins, all data within the FIFO is discarded and the FIFO resets so that read and write address pointers are at their starting position.

When the control signal $\overline{\text{FM_I/E}}$ is low, the user has full control over reading from and writing to the FIFO, including the FIFO reset ($\overline{\text{FFRST}}$) and FIFO write enable ($\overline{\text{WEN}}$).

The ANC data output $\overline{\text{ANC_OUT}}[9:0]$ can be set to a high Z state with the $\overline{\text{FOEN}}$ control signal. When $\overline{\text{FOEN}}$ is low, the $\overline{\text{ANC_OUT}}[9:0]$ outputs are enabled. When $\overline{\text{FOEN}}$ is high, the $\overline{\text{ANC_OUT}}[9:0]$ outputs are in a high Z state. Internal read address pointers are incremented regardless of the state of $\overline{\text{FOEN}}$ when $\overline{\text{REN}}$ is low.

3.6.3 FIFO Read Control

The FIFO control signal $\overline{\text{REN}}$ is the read enable signal used to access ANC data in the internal FIFO through the FIFO interface. The user can access only one of the two internal FIFO buffers at a time. The LUMA FIFO can be read when $\overline{\text{ANC_Y/C}}$ is high. The CHROMA FIFO can be read when $\overline{\text{ANC_Y/C}}$ is low.

When the internal FIFO is not in the empty or underrun states, it is ready to provide ANC data to the user. At this point, the user should read up to 1024 data words from each FIFO through the FIFO interface. When $\overline{\text{REN}}$ is low and a rising edge on R_CLK is detected, the device outputs the next word stored in the FIFO. Each time R_CLK is toggled while $\overline{\text{REN}}$ is low, the internal read address pointer (LUMA or CHROMA) is incremented. When $\overline{\text{REN}}$ is high, the read address pointer is not incremented.

3.6.4 FIFO Write Control

The FIFO control signal $\overline{\text{WEN}}$ is the write enable signal. It enables the ANC data extraction from either the LUMA or the CHROMA video streams into the internal respective FIFO buffers. When $\overline{\text{WEN}}$ is LOW, the write address pointer increments with the internal clock at the video data rate. When $\overline{\text{WEN}}$ is HIGH, the write address pointer does not increment. To reset both address pointers for read and write to their starting positions, toggle the FIFO reset signal $\overline{\text{FFRST}}$ from high to low.

3.6.5 FIFO External Reset

In external FIFO control mode, the internal FIFO address pointers are reset to zero (0) using $\overline{\text{FFRST}}$. A recommended external reset process is shown in Figure 16.

3.7 READING CRC ERROR FLAGS

The GS1500 provides error flags which track the Cyclic Redundancy Code embedded in each line of LUMA and CHROMA video streams (LINE_CRC_ERR_Y and LINE_CRC_ERR_C , respectively).

NOTE: For users monitoring the status of the CRC error flags, it is strongly recommended that they are read only when $\overline{\text{FOEN}}$ is low.

TABLE 3: Source Format Parameters

Reference SMPTE Standard	260M	260M	295M	274M	274M	274M	274M	274M	274M	274M	274M	296M	296M
Format ID	A	B	C	D	E	F	G	H	I	J	K	L	M
Lines/Frame	1125	1125	1250	1125	1125	1125	1125	1125	1125	1125	1125	750	750
Words/Active Line (each channel Y, Cb/Cr)	1920	1920	1920	1920	1920	1920	1920	1920	1920	1920	1920	1280	1280
Total Active Lines	1035	1035	1080	1080	1080	1080	1080	1080	1080	1080	1080	720	720
Words/Total Line (each channel Y, Cb/Cr)	2200	2200	2376	2200	2200	2640	2200	2200	2640	2750	2750	1650	1650
Frame Rate (Hz)	30	30/M	25	30	30/M	25	30	30/M	25	24	24/M	60	60/M
Fields /Frame	2	2	2	2	2	2	1	1	1	1	1	1	1
Data Rate Divisor	1	M	1	1	M	1	1	M	1	1	M	1	M

NOTE: M=1.001 in the above table.

TABLE 4: FIFO Status Indicator

FF_STA[2:0]	DESCRIPTION	SYNCHRONIZED TO
000	ERROR Flag; FIFO is under run	R_CLK
001	FIFO is empty	R_CLK
010	FIFO is almost empty; <= 32 bytes filled	R_CLK
011	FIFO is ready	-
100	FIFO is half full	PCLK_IN
101	FIFO is almost full; >= 992 bytes filled	PCLK_IN
110	FIFO is full	PCLK_IN
111	ERROR Flag; FIFO is over run	PCLK_IN

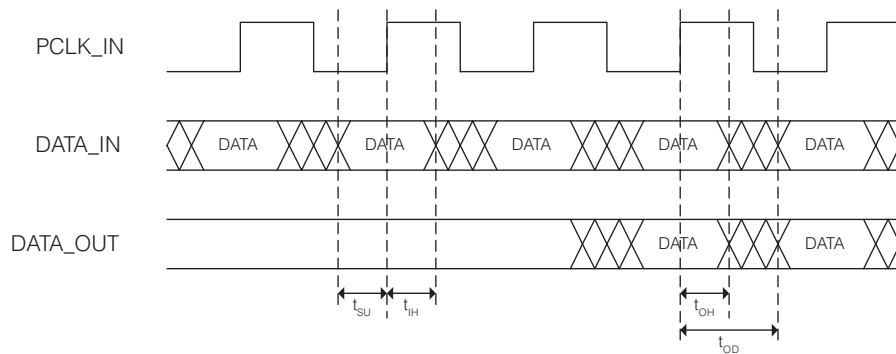

Fig. 1 Synchronous I/O Timing

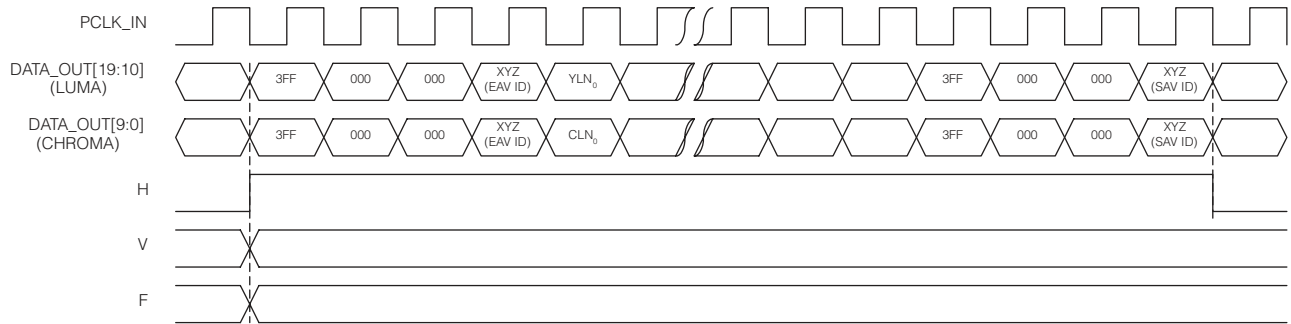

Fig. 2 HVF Timing

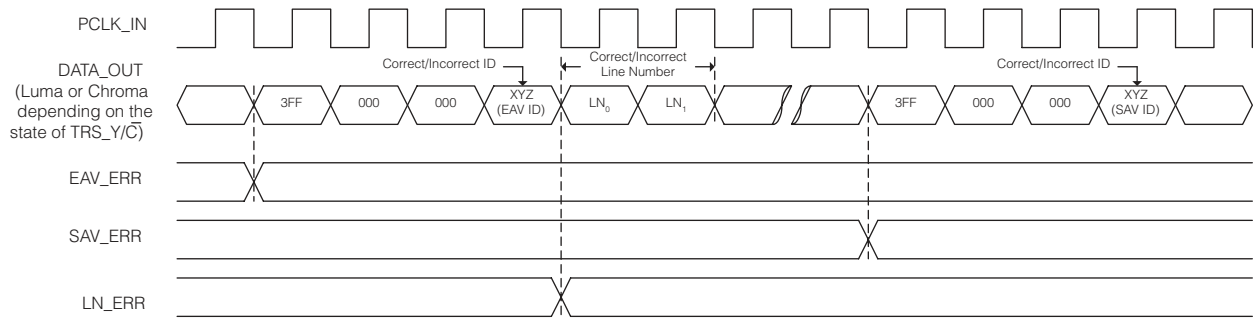

Fig. 3 EAV_ERR, SAV_ERR and LN_ERR Timing

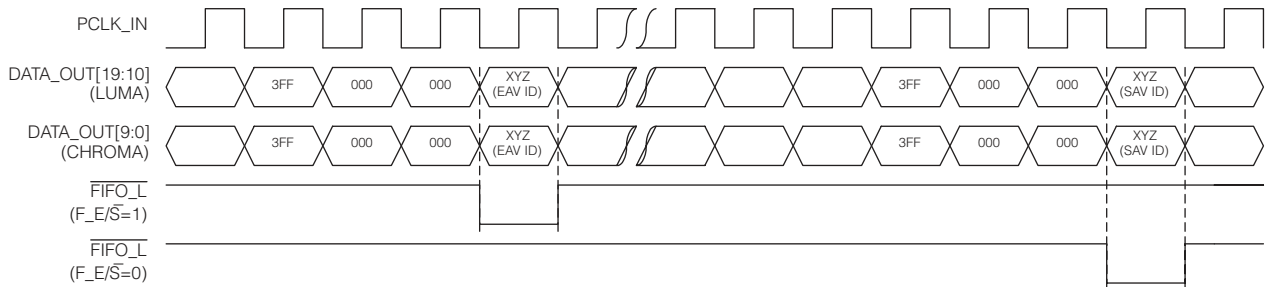

Fig. 4 FIFO_L Timing

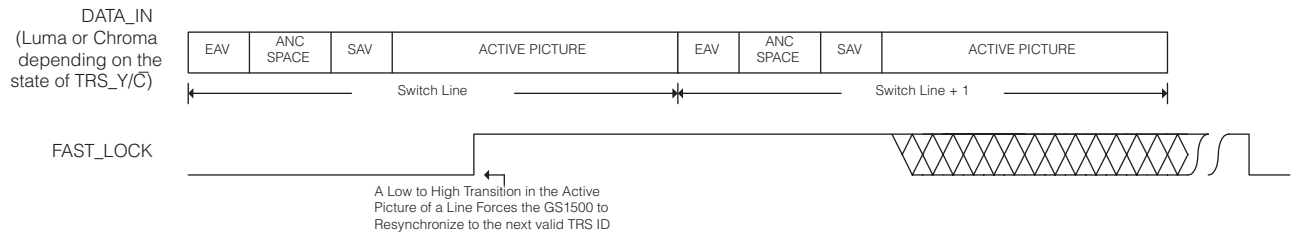

Fig. 5 FAST_LOCK Timing

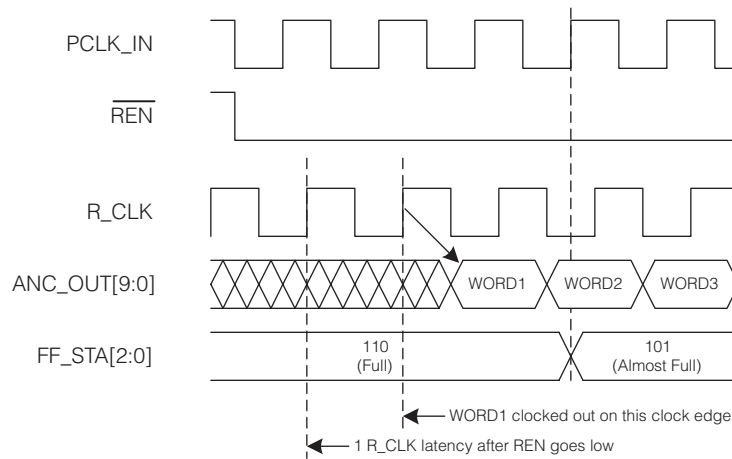

Fig. 6 FIFO Full to Almost Full Read Timing

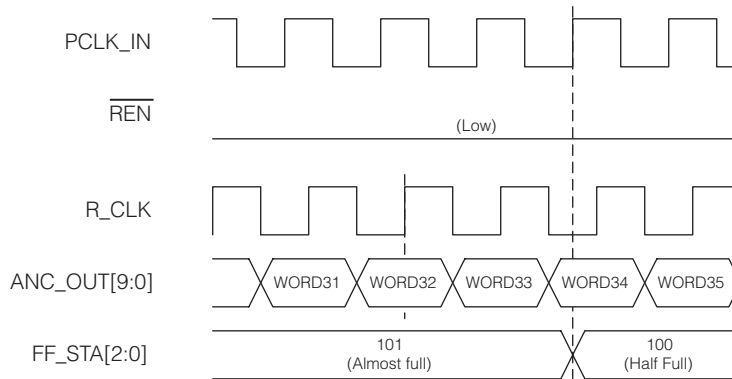

Fig. 7 FIFO Almost Full to Half Full Read Timing

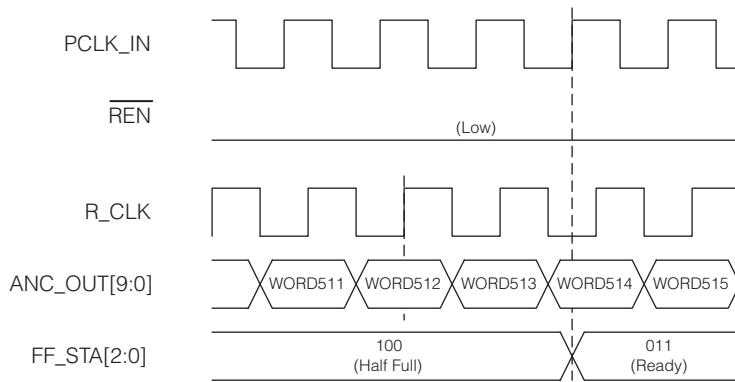

Fig. 8 FIFO Half Full to Ready Read Timing

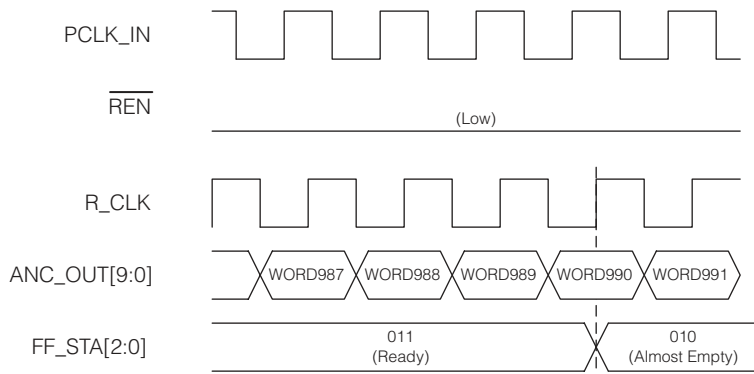

Fig. 9 FIFO Ready to Almost Empty Read Timing

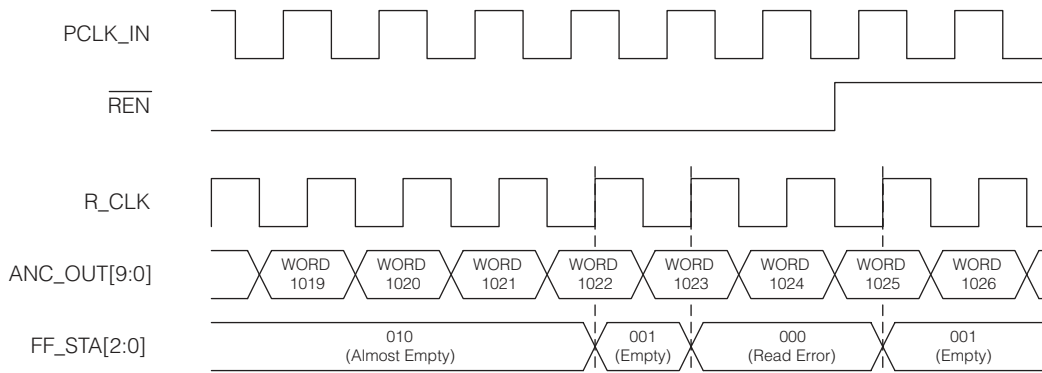

Fig. 10 FIFO Almost Empty to Empty to Read Error Read Timing

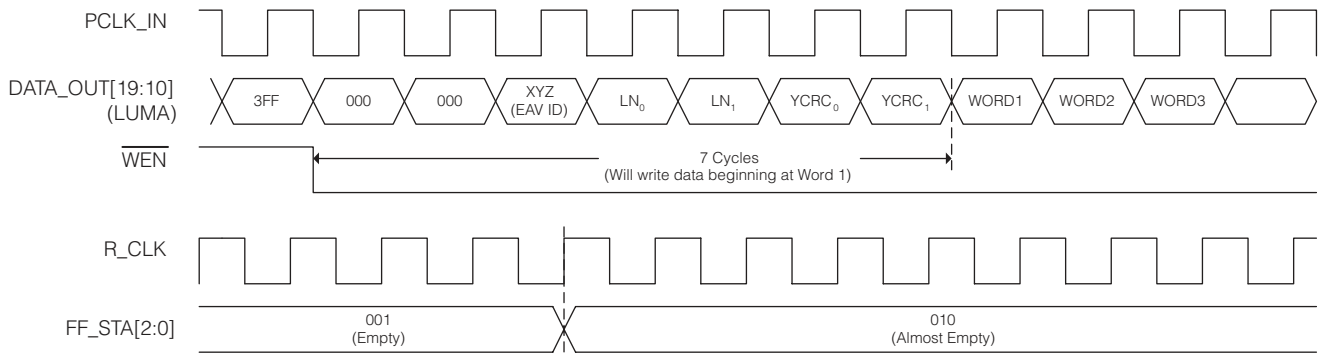

Fig. 11 FIFO Empty to Almost Empty Write Timing

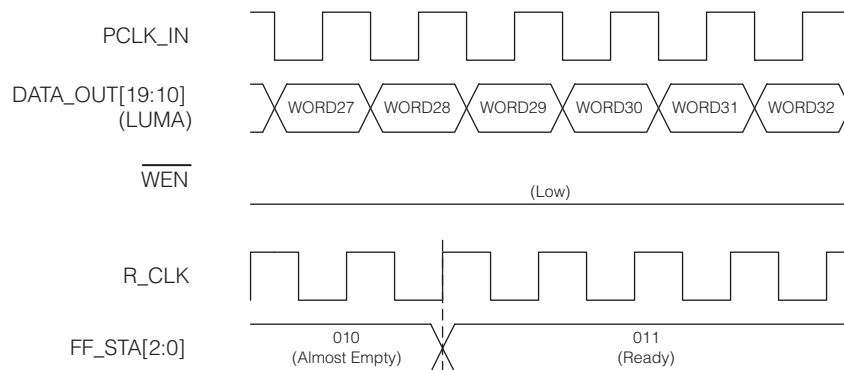

Fig. 12 FIFO Almost Empty to Ready Write Timing

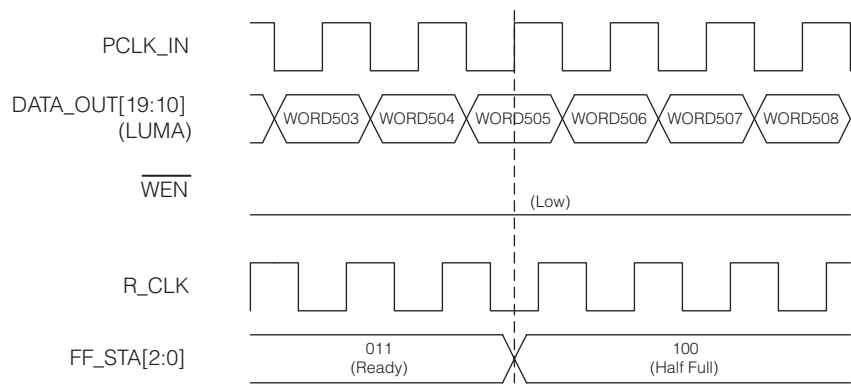

Fig. 13 FIFO Ready to Half Full Write Timing

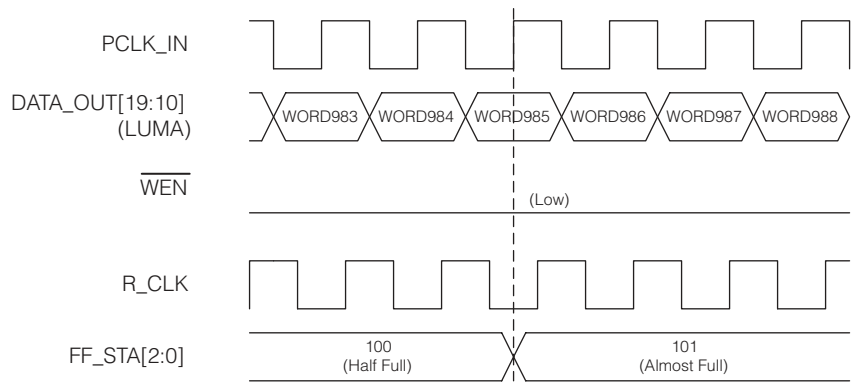

Fig. 14 FIFO Half Full to Almost Full Write Timing

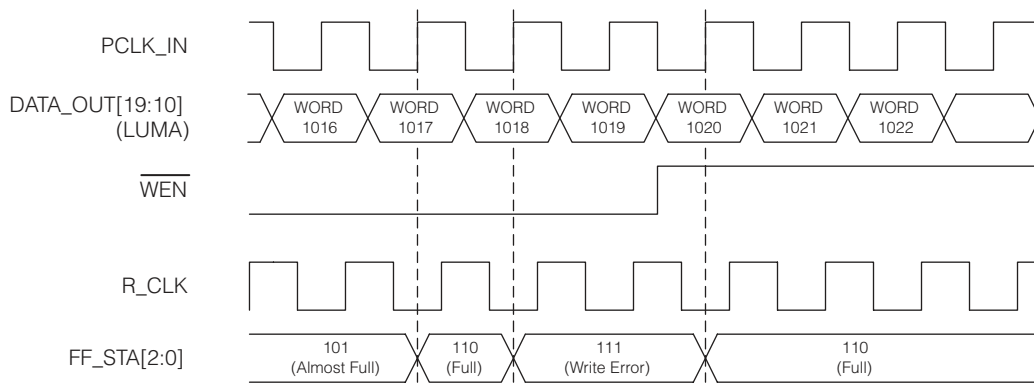

Fig. 15 FIFO Almost Full to Full to Write Error Timing

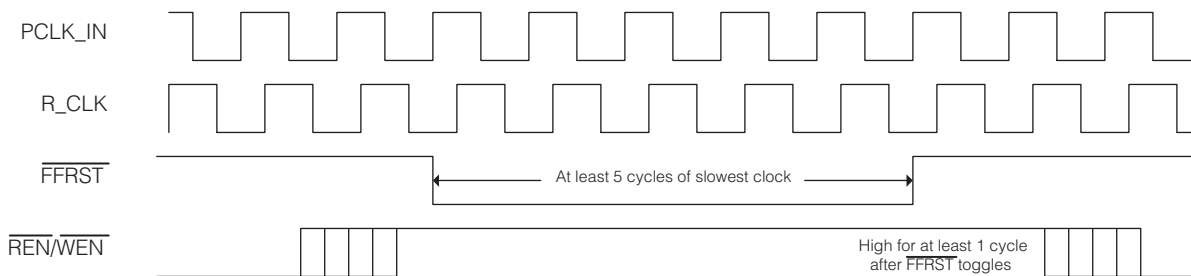

Fig. 16 Recommended External FIFO Reset Process

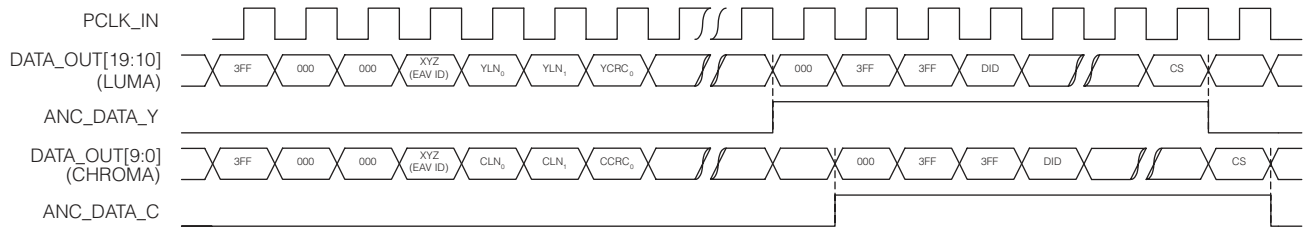

Fig. 17 ANC_DATA_Y and ANC_DATA_C Timing

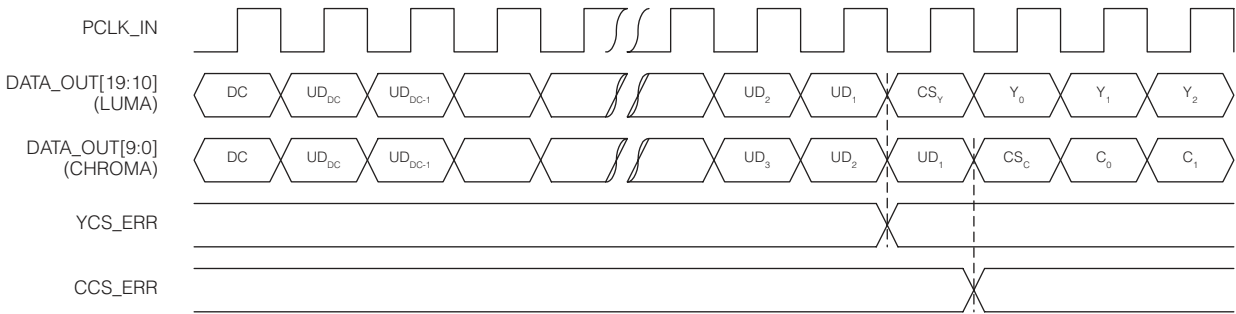

Fig. 18 YCS_ERR and CCS_ERR Timing

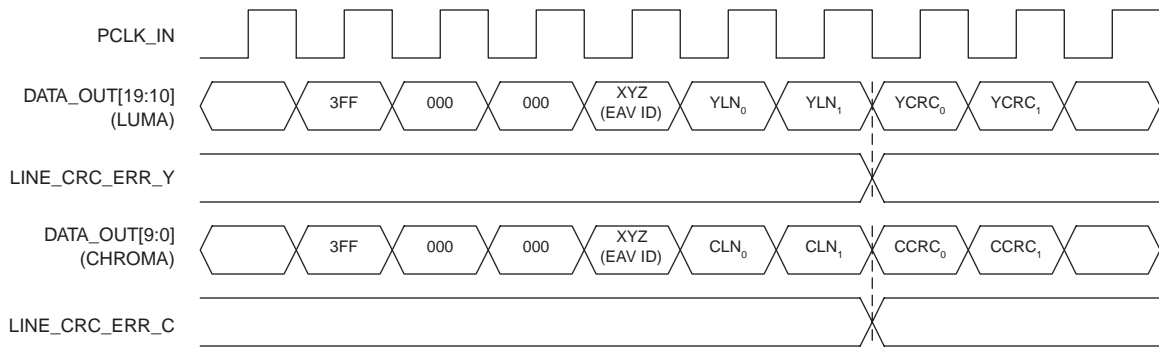

Fig. 19 Luma and Chroma LINE_CRC_ERR Timing

4. REFERENCES

Compliant with SMPTE 292M.

5. PACKAGE & ORDERING INFORMATION

5.1 PACKAGE DIMENSIONS

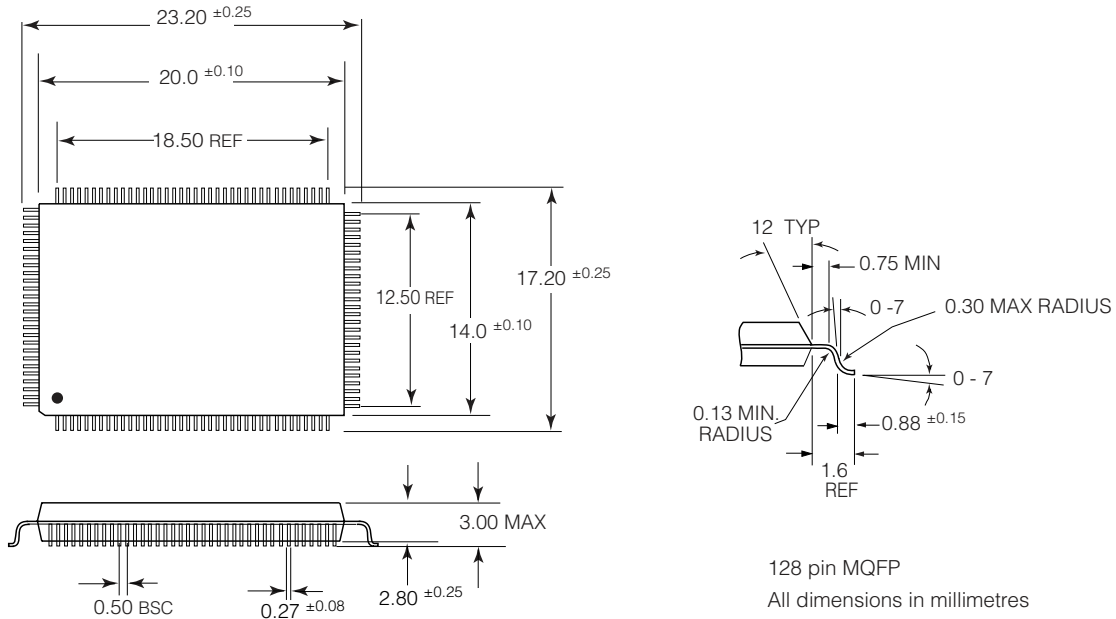

5.2 ORDERING INFORMATION

PART NUMBER	PACKAGE	TEMPERATURE RANGE	Pb-FREE AND GREEN
GS1500-CQR	128 pin MQFP	0°C to 70°C	No
GS1500-CQRE3	128 pin MQFP	0°C to 70°C	Yes

CAUTION
ELECTROSTATIC
SENSITIVE DEVICES
DO NOT OPEN PACKAGES OR HANDLE
EXCEPT AT A STATIC-FREE WORKSTATION



DOCUMENT IDENTIFICATION
DATA SHEET
The product is in production. Gennum reserves the right to make changes at any time to improve reliability, function or design, in order to provide the best product possible.

REVISION NOTES:
Adding Pb-free and Green information.

For latest product information, visit www.gennum.com

GENNUM CORPORATION

MAILING ADDRESS:
P.O. Box 489, Stn. A, Burlington, Ontario, Canada L7R 3Y3
Tel. +1 (905) 632-2996 Fax. +1 (905) 632-5946

SHIPPING ADDRESS:
970 Fraser Drive, Burlington, Ontario, Canada L7L 5P5

GENNUM JAPAN CORPORATION

Shinjuku Green Tower Building 27F 6-14-1, Nishi Shinjuku Shinjuku-ku,
Tokyo 160-0023 Japan
Tel: +81 (03) 3349-5501 Fax: +81 (03) 3349-5505

GENNUM UK LIMITED

25 Long Garden Walk, Farnham, Surrey, England GU9 7HX
Tel. +44 (0)1252 747 000 Fax +44 (0)1252 726 523

Gennum Corporation assumes no responsibility for the use of any circuits described herein and makes no representations that they are free from patent infringement.

© Copyright May 2002 Gennum Corporation. All rights reserved. Printed in Canada.