

NOTES:

1. MATERIAL:

- A) BACKSHELL COPPER ALLOY 172 PER QQ-C-533B.
- B) BACKSHELL SCREW STAINLESS STEEL PER SAE-AMS-QQ-S-763, 300 SERIES
- C) CLAMP BAR ALUMINUM ALLOY
- D) CLAMP INSERT SILICONE ELASTOMER PER MIL-R-25988.
- E) CLAMP SCREW STAINLESS STEEL PER QQ-S-763, 300 SERIES

2. FINISH:

- A) BACKSHELL CADMIUM PLATED PER SAE-AMS-QQ-P-416
- B) BACKSHELL SCREW CADMIUM PLATED PER SAE-AMS-QQ-P-416
- C) CLAMP BAR CADMIUM PLATED PER SAE-AMS-QQ-P-416
- D) CLAMP SCREW CADMIUM PLATED PER SAE-AMS-QQ-P-416

3 RAYCHEM PART NUMBER AND DATE CODE ARE STAMPED APPROXIMATELY AS SHOWN.

REVISIONS			
LTR	DESCRIPTION	DATE	APPROVED
A	REVISED PER ECN T-17673	92 AUG 10	J.B.
B	REDRAWN PER DCR# T-31338	10/21/2002	M.HIGGY

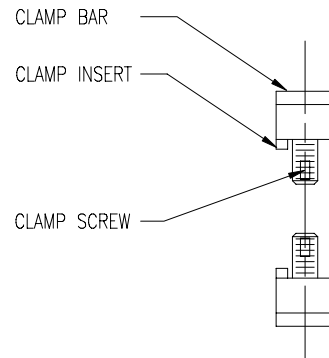
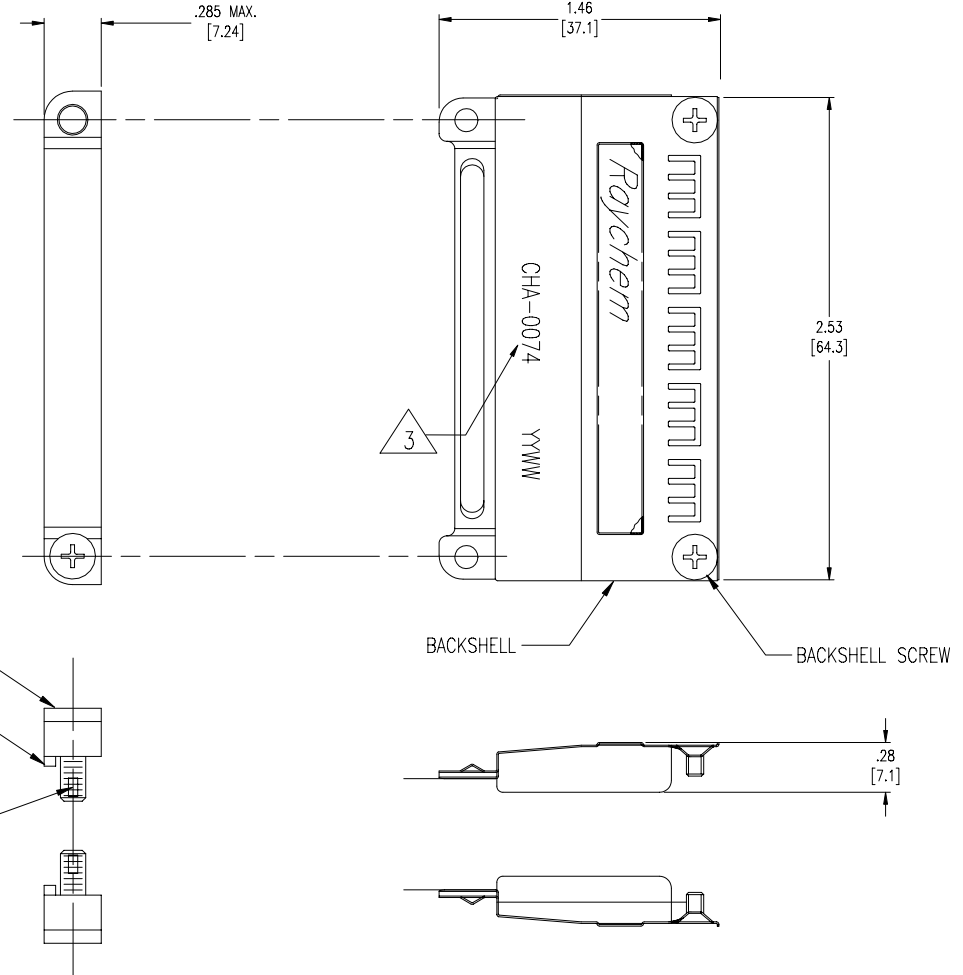

SPECIFICATION CONTROL DRAWING

UNLESS OTHERWISE SPECIFIED DIMENSIONS ARE IN INCHES. METRIC DIMENSIONS ARE IN BRACKETS. DECIMALS .XXX ±.005 { .13 mm } .XX ±.02 { .5 mm } .X ± ANGLES WEIGHT: .046 LBS. (20.86 GRM.) MAX.	DRAWN	ZS.ORBAN	9/5/2002	tyco Electronics Raychem Products 305 Constitution Drive Menlo Park, CA. 94025 USA	
	CHECKED				TITLE
	APPROVED				BACKSHELL, RECEPTACLE, EME, FCC. 2" CADMIUM PLATED, MTC SERIES
	APPROVED	M.HIGGY	9/5/2002	CAD NAME	T31338.DWG
	THIRD ANGLE PROJECTION			SIZE C CODE IDENT. NO. 06090 DWG. NO. CHA-0074 REV B DO NOT SCALE THIS DRAWING SHEET 1 OF 1	

If this document is printed it becomes uncontrolled.
Check for the latest revision.