AT89ISP Programmer Cable

1. Introduction

This application note describes the Atmel® AT89ISP cable interface. This in-system programmer cable communicates serially with Atmel's AT89S/AT89LP microcontrollers and reprograms them in the circuit without removal. For surface-mounted devices, eliminating this step greatly reduces the possibility of damages caused by insertion/removal of delicate leads, and allows for design changes and software/parameter updates in the field.

2. Parallel Port Settings

For optimal operation, it is recommended that the user's PC/laptop parallel port setting be configured for EPP (Enhanced Parallel Port). This can be done in the BIOS screen after a boot-up sequence.

For laptops without a parallel port, a USB-to-Parallel converter product such as the one featured in the following link is recommended:

<http://www.dpie.com/pcmcia/spp100.html>

3. AT89ISP Software

The AT89ISP software is the primary means for performing in-system programming (ISP) of Atmel AT89S/AT89LP devices. It provides an intuitive interface for in-system programming that can be run from a personal computer. The software will run under the Windows® 9x/ME/2000/XP, Windows NT® operating systems. The software has a comprehensive set of features that allows a user to view, program, and erase data from an Atmel AT89S/AT89LP device. A detailed Adobe® Acrobat® document describing the features/functions of the software accompanies it.

4. AT89ISP Cable

In order to use the AT89ISP software, the user will need to have an Atmel AT89ISP cable. This cable can be purchased directly from Atmel or authorized Atmel representatives. The ISP cable's pins need to be connected to an AT89S/AT89LP device in the manner shown in [Figure 5-1 on page 2](#). The 25-pin male connector plugs into the parallel port of the user's personal computer. The 10-pin female IDC header plugs into a 10-pin male header in the user's target board. A **polarized** 10-pin receptacle male header is highly recommended to avoid an erroneous connector mating. The pinout shown below represents the target 10-pin male header connector in the user's board as viewed from the top. **Please note that connection of the \overline{SS} pin (P1.4) is required for all the AT89LP (single-cycle core) derivatives, but not for the AT89S derivatives.**



AT89ISP Programmer Cable

Application Note

3310E-MICRO-10/06



Figure 4-1. AT89ISP Cable 10-pin **Male** Header Pinout

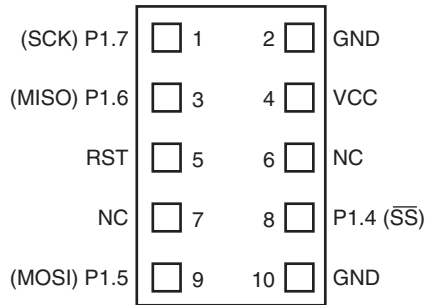

Note: NC = Not Connected.

5. Header Dimensions

Figure 5-1 shows the receptacle male header dimensions.

Figure 5-1. 10-pin **Male** Header Dimensions

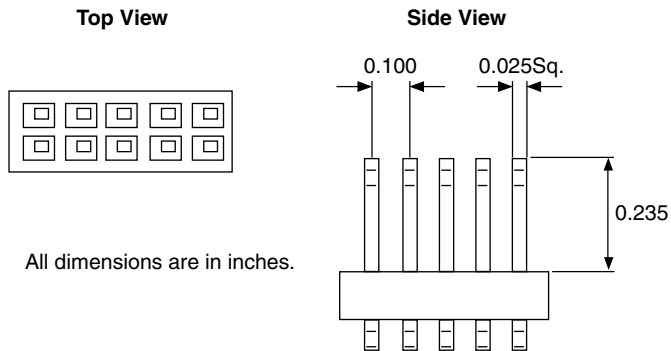

6. Connection

The correct way to connect the female header end of the AT89ISP cable to the 10-pin receptacle male header is to align the connector “arrow” towards pin 1, as illustrated in Figure 6-1. On the cable casing end, make sure the connector “arrow” sits visible next to the side of the small PC board (not away from it).

Figure 6-1. Proper Cable Alignment

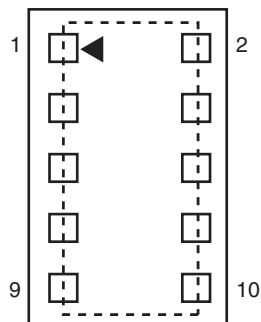
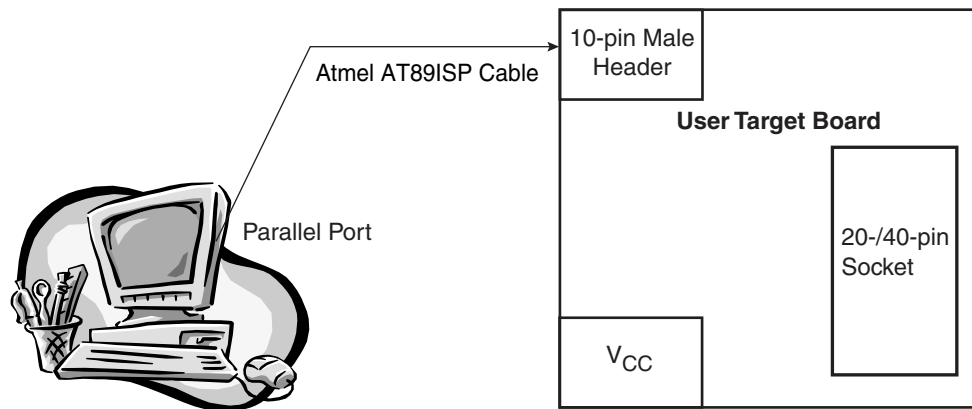

Table 6-1. Atmel AT89ISP Cable Pinout

Pin	Name	Comment
1	SCK	Serial Clock
3	MISO	Master In – Slave Out
4	V _{CC}	Target Power Supply
5	RST	Target MCU Reset
8	\overline{SS}	Slave Select
9	MOSI	Master Out – Slave In
2, 10	GND	Common Ground
6, 7	NC	No Connection

Figure 6-2. AT89ISP Target Board Sample Connection



7. Voltage Levels

The AT89ISP cable requires a regulated DC supply from the user target board. The cable should operate correctly between the specified operating voltage limits. The current operating V_{CC} voltage range for the AT89ISP cable is 2.7V to 5.5V.



Atmel Corporation

2325 Orchard Parkway
San Jose, CA 95131, USA
Tel: 1(408) 441-0311
Fax: 1(408) 487-2600

Regional Headquarters

Europe

Atmel Sarl
Route des Arsenalux 41
Case Postale 80
CH-1705 Fribourg
Switzerland
Tel: (41) 26-426-5555
Fax: (41) 26-426-5500

Asia

Room 1219
Chinachem Golden Plaza
77 Mody Road Tsimshatsui
East Kowloon
Hong Kong
Tel: (852) 2721-9778
Fax: (852) 2722-1369

Japan

9F, Tonetsu Shinkawa Bldg.
1-24-8 Shinkawa
Chuo-ku, Tokyo 104-0033
Japan
Tel: (81) 3-3523-3551
Fax: (81) 3-3523-7581

Atmel Operations

Memory

2325 Orchard Parkway
San Jose, CA 95131, USA
Tel: 1(408) 441-0311
Fax: 1(408) 436-4314

Microcontrollers

2325 Orchard Parkway
San Jose, CA 95131, USA
Tel: 1(408) 441-0311
Fax: 1(408) 436-4314

La Chantrerie
BP 70602
44306 Nantes Cedex 3, France
Tel: (33) 2-40-18-18-18
Fax: (33) 2-40-18-19-60

ASIC/ASSP/Smart Cards

Zone Industrielle
13106 Rousset Cedex, France
Tel: (33) 4-42-53-60-00
Fax: (33) 4-42-53-60-01

1150 East Cheyenne Mtn. Blvd.
Colorado Springs, CO 80906, USA
Tel: 1(719) 576-3300
Fax: 1(719) 540-1759

Scottish Enterprise Technology Park
Maxwell Building
East Kilbride G75 0QR, Scotland
Tel: (44) 1355-803-000
Fax: (44) 1355-242-743

RF/Automotive

Theresienstrasse 2
Postfach 3535
74025 Heilbronn, Germany
Tel: (49) 71-31-67-0
Fax: (49) 71-31-67-2340

1150 East Cheyenne Mtn. Blvd.
Colorado Springs, CO 80906, USA
Tel: 1(719) 576-3300
Fax: 1(719) 540-1759

Biometrics/Imaging/Hi-Rel MPU/ High Speed Converters/RF Datacom

Avenue de Rochepleine
BP 123
38521 Saint-Egreve Cedex, France
Tel: (33) 4-76-58-30-00
Fax: (33) 4-76-58-34-80

Literature Requests

www.atmel.com/literature

Disclaimer: The information in this document is provided in connection with Atmel products. No license, express or implied, by estoppel or otherwise, to any intellectual property right is granted by this document or in connection with the sale of Atmel products. **EXCEPT AS SET FORTH IN ATMEL'S TERMS AND CONDITIONS OF SALE LOCATED ON ATMEL'S WEB SITE, ATMEL ASSUMES NO LIABILITY WHATSOEVER AND DISCLAIMS ANY EXPRESS, IMPLIED OR STATUTORY WARRANTY RELATING TO ITS PRODUCTS INCLUDING, BUT NOT LIMITED TO, THE IMPLIED WARRANTY OF MERCHANTABILITY, FITNESS FOR A PARTICULAR PURPOSE, OR NON-INFRINGEMENT. IN NO EVENT SHALL ATMEL BE LIABLE FOR ANY DIRECT, INDIRECT, CONSEQUENTIAL, PUNITIVE, SPECIAL OR INCIDENTAL DAMAGES (INCLUDING, WITHOUT LIMITATION, DAMAGES FOR LOSS OF PROFITS, BUSINESS INTERRUPTION, OR LOSS OF INFORMATION) ARISING OUT OF THE USE OR INABILITY TO USE THIS DOCUMENT, EVEN IF ATMEL HAS BEEN ADVISED OF THE POSSIBILITY OF SUCH DAMAGES.** Atmel makes no representations or warranties with respect to the accuracy or completeness of the contents of this document and reserves the right to make changes to specifications and product descriptions at any time without notice. Atmel does not make any commitment to update the information contained herein. Unless specifically provided otherwise, Atmel products are not suitable for, and shall not be used in, automotive applications. Atmel's products are not intended, authorized, or warranted for use as components in applications intended to support or sustain life.

© 2006 Atmel Corporation. All rights reserved. Atmel®, logo and combinations thereof, Everywhere You Are® and others, are registered trademarks or trademarks of Atmel Corporation or its subsidiaries. Windows® and others are registered trademarks of Microsoft Corporation. Other terms and product names may be trademarks of others.



Printed on recycled paper.

3310E-MICRO-10/06