

THIS DRAWING IS UNPUBLISHED. RELEASED FOR PUBLICATION
 © COPYRIGHT BY TYCO ELECTRONICS CORPORATION. ALL RIGHTS RESERVED.

LOC	DIST	REVISIONS					
		P	LTR	DESCRIPTION	DATE	DWN	APVD
AJ	16	A		REVISED PER EC 0514-0150-05	10OCT2005	REH	KW

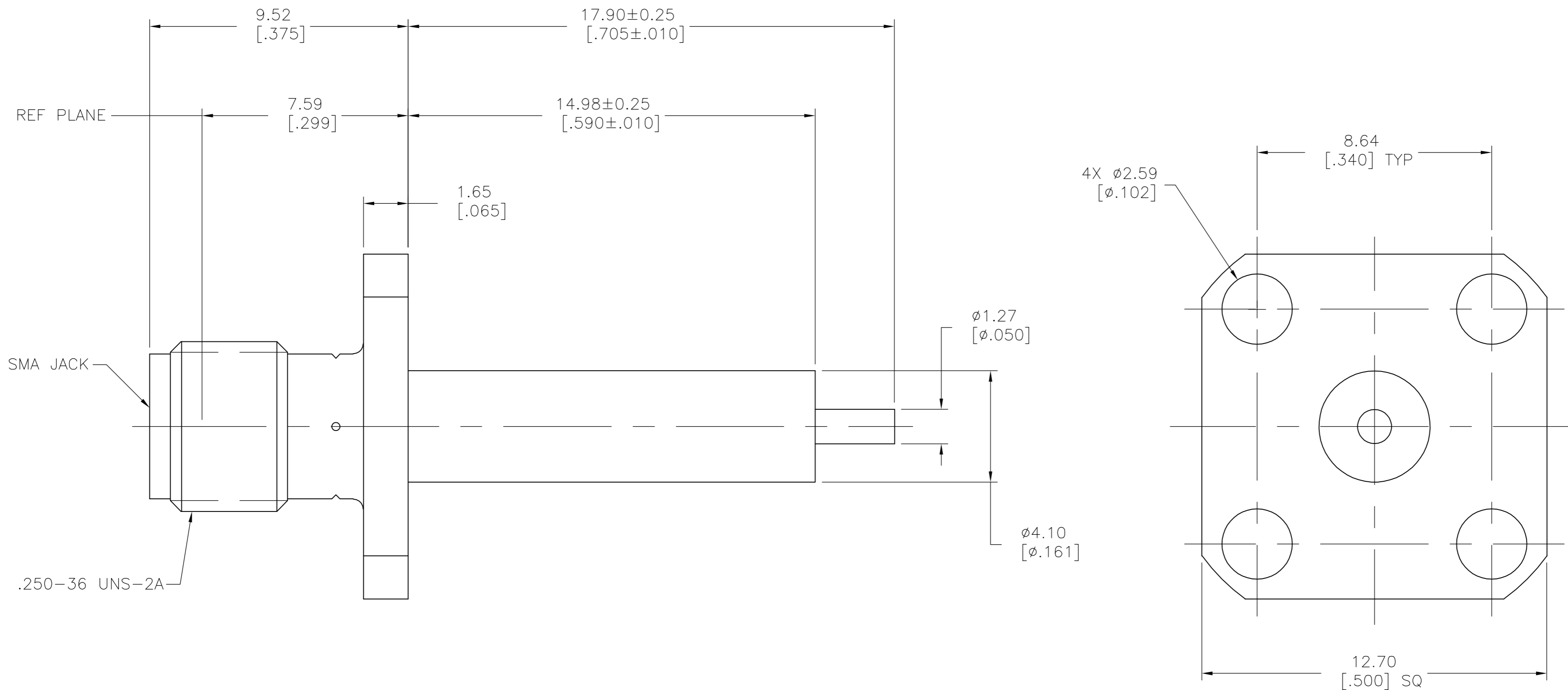

ELECTRICAL	MECHANICAL	ENVIRONMENTAL
Nominal Impedance (Ohms) 50	Interface Dimensions MIL-STD-348A, Fig. 310.2	TEMPERATURE RATING -65°C TO +125°C
Frequency Range (GHz) DC to 6	Recommended Mating	Vibration MIL-STD-202, Method 204, Condition D
Volt Rating (VRMS MAX) @ Sea Level 335	Torque 3-5 in-lbs (0.34-0.57 Nm)	Shock MIL-STD-202, Method 213, Condition I
VSWR 1.40:1	Mating Characteristics:	Thermal Shock MIL-STD-202, Method 107, Condition A
Insertion Loss (dB MAX) .07 √f(GHz)	Insertion (MAX Lbs) 3.0 (1.36 Kg)	Moisture Resistance MIL-STD-202, Method 106, except step 7b is omitted. No measurement at high humidity. Insulation resistance shall be at least 200 Megohms within 5 minutes after removal from humidity.
RF Leakage (dB MIN) -90 @ 2 to 3 GHz	Withdrawal (MIN Oz) 1.0 (28.35 g)	
Corona, 70,000 Ft (VRMS MIN) 250	Force to Engage and Disengage (in-Lbs MAX) 2.0 (0.23 Nm)	
Dielectric Withstanding Voltage (VRMS MIN) @ Sea Level 1000	Center Contact Captivation	
Contact Resistance (Milliohms MAX)	Axial (Lbs) 6.0 (2.7 Kg) MIN	
Center Contact 3.0	FRDM INTERFACE	
Outer Contact 2.0	Axial (Lbs) 4.0 (1.8 Kg) MIN	
Cable to Housing N/A	FRDM FLANGE	
RF High Potential @ Sea Level (VRMS MIN @ 5 MHz) 670	Radial (In-Oz) 4.0 (0.028 Nm)	
I.R.(Megohms MIN) 5,000		

COMPONENT	MATERIAL	FINISH
HOUSING	BRASS, PER ASTM-B-16 HALF HARD OR CZ121 PER BS2874	WHITE BRONZE PLATE
DIELECTRIC	TFE FLUOROCARBON PER ASTM-D-1457	N/A
CENTER CONTACT	BERYLLIUM COPPER PER ASTM-B-196 OR ASTM-B-197 ALLOY C17300, CONDITION H	GOLD PLATE

THIS DRAWING IS A CONTROLLED DOCUMENT.	
DIMENSIONS: mm [INCHES]	TOLERANCES UNLESS OTHERWISE SPECIFIED:
	0 PLC ± -
	1 PLC ± -
	2 PLC ± 0.13 [.005]
	3 PLC ± -
MATERIAL	FINISH
-	-

DWN B. MCMASTER 28APR05		Tyco Electronics Corporation	
CHK J. HAVENER 28APR05		Harrisburg, PA 17105-3608	
APVD J. HAVENER 28APR05		NAME	
PRODUCT SPEC		SMA, 4 HOLE FLANGE MOUNT JACK RECEPTACLE, STRAIGHT TERMINAL (2252-1901-36)	
APPLICATION SPEC	SIZE A2	CAGE CODE 00779	DRAWING NO C=6086493
WEIGHT -	RESTRICTED TO		
CUSTOMER DRAWING	SCALE 8:1	SHEET 1 of 1	REV A

6086493-1
PART NUMBER