

# MLX90822

Absolute Pressure Sensor with analog output  
Datasheet

## 1. Features and Benefits

- +/-0.5% full scale lifetime accuracy
- Ratiometric analog output
- Fast response time (min 0.4ms)
- All-in-one solution: MEMS, interface and passive components in one easy to integrate package validated according to leading OEM EMC standards
- -40°C to 160°C temperature range, up to 170°C for short durations
- Excellent harsh media resistance against halogens, acids, ...
- Qualified according to AEC-Q100 and AEC-Q103-002
- Configurable diagnostic features like internal broken connection, over voltage, under voltage, ...
- Factory calibrated and fully programmable through the connector with the PTC04 programming tool for customized calibration curves
- Extended over (+40V) and reverse (-40V) voltage capabilities (supply & output)
- Easy to use due to its PCB-less package with ridges to enable glued pressure seals
- ASIL compliant developed as an ASIL A SEooC as per ISO 26262



## 2. Application Examples

- Automotive applications with absolute pressure from 1bar to 4bar
- Manifold and Turbo Manifold Air Pressure for automotive, truck and motorcycle applications
- Air management for any combustion powered applications (boat, mower tractor, chainsaw, ...)
- CNG/LPG injectors



Figure 1: MLX90822

# MLX90822

Absolute Pressure Sensor with analog output  
Datasheet

## 3. Ordering Information

Ordering Code	Temperature	Package	Option code	Packing
MLX90822GXP-BAA-300-RE	-40°C to 160°C	SMP7	0.1 to 1.15bar absolute pressure 0.5V to 4.5V analog output	Reel
MLX90822GXP-BAA-304-RE	-40°C to 160°C	SMP7	0.1 to 1.15bar absolute pressure 0.4V to 4.65V analog output	Reel
MLX90822GXP-BAB-301-RE	-40°C to 160°C	SMP7	0.1 to 3bar absolute pressure 0.5V to 4.5V analog output	Reel
MLX90822GXP-BAB-302-RE	-40°C to 160°C	SMP7	0.1 to 4bar absolute pressure 0.5V to 4.5V analog output	Reel

## MLX90822GXP-BAA-300-RE

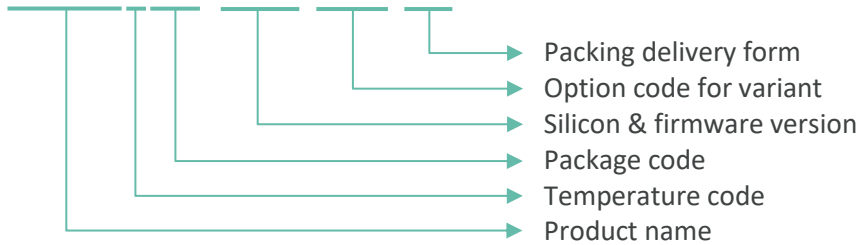

## 4. Package Diagram

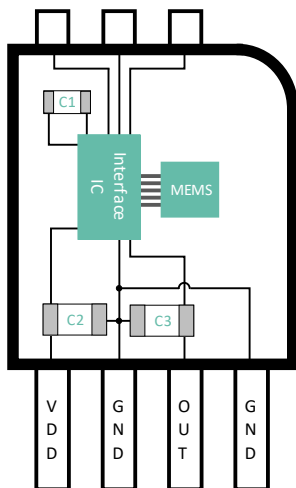

Component	Value
C1	47nF
C2	100nF
C3	100nF

Table 1: MLX90822 capacitors configuration

Figure 2: Internal wiring of MLX90822

## 5. General Description

The MLX90822 is a packaged PCB-less, factory calibrated, absolute pressure sensor measuring spans from 1 to 4 bar. It delivers an analog output signal.

The MLX90822 consists of a MEMS pressure sensor element, an interface chip (CMOS technology) and passive components. This optimized solution exhibits excellent EMC performance. The DSP based signal interface provides outstanding initial accuracy. A smart package and die assembly concept enable high output stability over life, even in stringent automotive temperature and stress conditions.

# MLX90822

Absolute Pressure Sensor with analog output  
Datasheet

## Contents

1. Features and Benefits.....	1
2. Application Examples.....	1
3. Ordering Information .....	2
4. Package Diagram .....	2
5. General Description.....	2
6. Glossary of Terms.....	4
7. Absolute Maximum Ratings .....	4
8. Pin Definitions and Descriptions .....	5
9. General Electrical Specifications .....	6
10. Detailed General Description.....	7
11. Default Programmed Settings.....	8
11.1. MLX90822GXP-BAA-300.....	9
11.2. MLX90822GXP-BAA-304.....	9
11.3. MLX90822GXP-BAB-301.....	10
11.4. MLX90822GXP-BAB-302.....	10
12. Diagnostics .....	11
12.1. Broken Connection Diagnostics .....	11
12.2. Internal Diagnostics .....	11
13. Digital .....	12
14. Application Information.....	12
15. Storage and Handling of Plastic Encapsulated ICs.....	13
16. Assembly of Encapsulated ICs.....	13
17. Environment and Sustainability .....	13
18. Package Information.....	14
19. Disclaimer.....	15

## 6. Glossary of Terms

- Absolute pressure: Pressure measured relative to a vacuum reference
- ADC: Analog to Digital Converter
- Bar: Pressure unit (1bar = 100kPa)
- DSP: Digital Signal Processor
- EMC: Electro Magnetic Compatibility
- FS: Full scale, span
- HTOL: High-temperature operating life
- Lower Fault Band: Output voltage below normal output range to indicate a diagnostic
- OV: Over Voltage
- PCB: Printed Circuit Board
- POR: Power-on Reset
- PTC04: Melexis Programming Tool
- RV: Reverse Voltage
- SEooC: Safety Element out of Context
- TA: Ambient temperature
- Upper Fault Band: Output voltage above normal output range to indicate a diagnostic

## 7. Absolute Maximum Ratings

Parameter	Symbol	Value	Units	Comment
Supply Voltage (overvoltage)	OV	40	V	Max 2 hours
Reverse Voltage Protection	RV	-40	V	
Positive output voltage		40	V	
Reverse output voltage <sup>(1)</sup>		-40	V	
Operating Ambient Temperature Range <sup>2</sup>	T <sub>A</sub>	-40 to 160	°C	
Extended Operating Ambient Temperature Range		-40 to 170	°C	10 minutes continuous period, max 20 hours total duration over life
Storage Temperature Range		-40 to 160	°C	
Programming Ambient Temperature Range		-40 to 125	°C	
Proof pressure (1 bar versions)		5	Bar	BAA-300 and BAA-304
Proof pressure (>3 bar versions)		10	Bar	BAB-301 and BAB-302
Burst pressure (1 bar versions)		6	Bar	BAA-300 and BAA-304
Burst pressure (>3 bar versions)		16	Bar	BAB-301 and BAB-302
ESD, human body model <sup>(3)</sup>		2000	V	Class 1C acc. ANSI/ESDA/JEDEC JS-001
ESD, charged device model <sup>(3)</sup>		1000	V	Class C3 acc. ANSI/ESDA/JEDEC JS-002

Table 2: Absolute maximum ratings

<sup>1</sup> Absolute maximum DC negative output at floating supply or supply shorted to output. Maximum DC negative output at operating supply: -5.5V.

<sup>2</sup> HTOL accelerated aging test equivalent to 3680 hours at 150°C.

<sup>3</sup> Device level performance including test pins. VDD, GND and SENT output are much more robust to account for module level ESD requirements.

# MLX90822

Absolute Pressure Sensor with analog output  
Datasheet

Exceeding the absolute maximum ratings may cause permanent damage. Exposure to absolute-maximum-rated conditions for extended periods may affect device reliability. Maximum duration of over voltage and reverse voltage conditions is 2 hours.

## 8. Pin Definitions and Descriptions

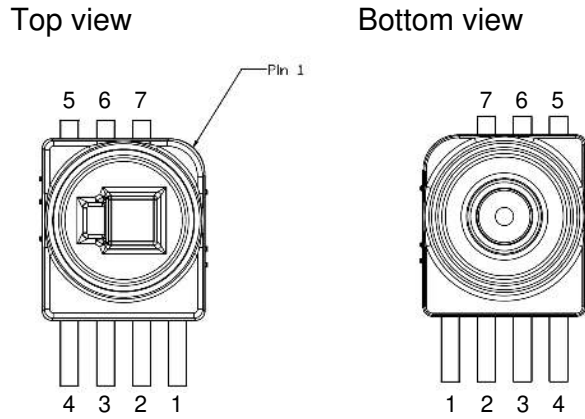

Figure 3: Package pinout

Pin number	Description
1	Ground (GND) <sup>(4)</sup>
2	Analog output
3	Ground (GND) <sup>(4)</sup>
4	Supply input (VDD)
5	Test pin
6	Test pin
7	Test pin

Table 3: Pinout definitions and descriptions

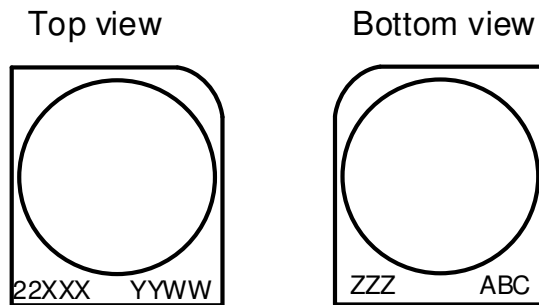

Figure 4: Package marking

Symbol	Function / Description
XXX	MEMS and ASIC traceability letter <sup>(5)</sup>
ZZZ	Last three characters of lot number
ABC	Sub lot indication
YYWW	Date code

Table 4: Package marking definition

<sup>4</sup> Either pin 1 or pin 3 can be used as Ground (GND) connection, it is not required to connect both pins. The unused pin may be left floating.

<sup>5</sup> Linked to first three letters of option code.

# MLX90822

Absolute Pressure Sensor with analog output  
Datasheet

## 9. General Electrical Specifications

DC Operating Parameters  $T_A = -40^{\circ}\text{C}$  to  $160^{\circ}\text{C}$

Parameter	Symbol	Remarks	Min	Typ <sup>(6)</sup>	Max	Units
Nominal supply voltage	Vdd		4.5	5	5.5	V
Nominal supply current	Idd	No output load		9.5	12	mA
Current consumption at supply overvoltage	IDD_OV				20	mA
Current consumption at supply reverse voltage	IDD_RV				20	mA
Output short-circuit current	IOUT_SH				20	mA
Resistive load on output	Rload	Pull up	3		425	kOhm
		Pull down	3		470	kOhm
Capacitive load on output	Cload	MLX90822 has an integrated 100nF output capacitor in its package. No additional capacitor needed.	0		110	nF
Output current	IOUT				2	mA
Under voltage detection range		Programmable. In default configuration set to 4.3V.	4.15		4.8	V
Over voltage detection range		Programmable. In default configuration set to 5.7V.	5.2		5.75	V
Under voltage detection tolerance			-50		50	mV
Over voltage detection tolerance			-50		50	mV
Power up time		Time from reaching minimum allowed supply voltage of 4.5V till having the output within specification			4	ms
Default response time <sup>(7)</sup>		For versions BAA-300, BAA-304, BAB-301, BAB-302			1	ms
Fastest response time <sup>(6)</sup>					0.4	ms
Refresh rate		Time between two consecutive updates on the output			75	$\mu\text{s}$
Operating Output voltage range		Output range where the linearity is in spec with any resistive load inside the specified range	4		96	%Vdd
Upper Fault Band			97		100	%Vdd
Lower Fault Band			0		3	%Vdd
Pressure output noise		Default configuration BAA-300, BAA-304, BAB-301, BAB-302			2	mV rms

Table 5: Electrical specifications

<sup>6</sup> Typical values are defined at  $T_A = +25^{\circ}\text{C}$  and  $V_{DD} = 5\text{V}$ .

<sup>7</sup> From input pressure step to output reaching 90% of settled output.

## 10. Detailed General Description

The MLX90822 consists of a pressure sensor element, a DSP-based interface chip and passive components.

The pressure sensor element consists of a diaphragm realized in the silicon chip by wafer bonding on an etched cavity with built in reference vacuum. The diaphragm reacts to a change in absolute pressure. The internal strain increases, in particular at the border of the diaphragm. Here, the piezo-resistive elements have been implanted into the silicon diaphragm forming a Wheatstone bridge, which act as a transducer.

The analog front-end of the interface chip applies filtering and converts the analog signal to a digital value. The DSP performs the compensations over temperature. Furthermore, the digital circuit provides some filtering, the possibility to linearize the pressure signal and also implements the clamping function. This chip has an analog output proportional to the pressure and supply voltage. A broken wire detection block ensures the analog output goes to one of the rails in case of a broken supply or ground connection.

Extensive protection of the supply lines and output allows the MLX90822 to handle extreme overvoltage conditions and makes it resistant to severe external disturbances. Several diagnostic functions (over-voltage, under-voltage, overpressure, under pressure detections) have been implemented on the MLX90822 and can be enabled by programming EEPROM settings. Figure 5 shows the MLX90822 block diagram. Passive components are integrated in the package to bring excellent EMC performance without the need for additional components at module level.

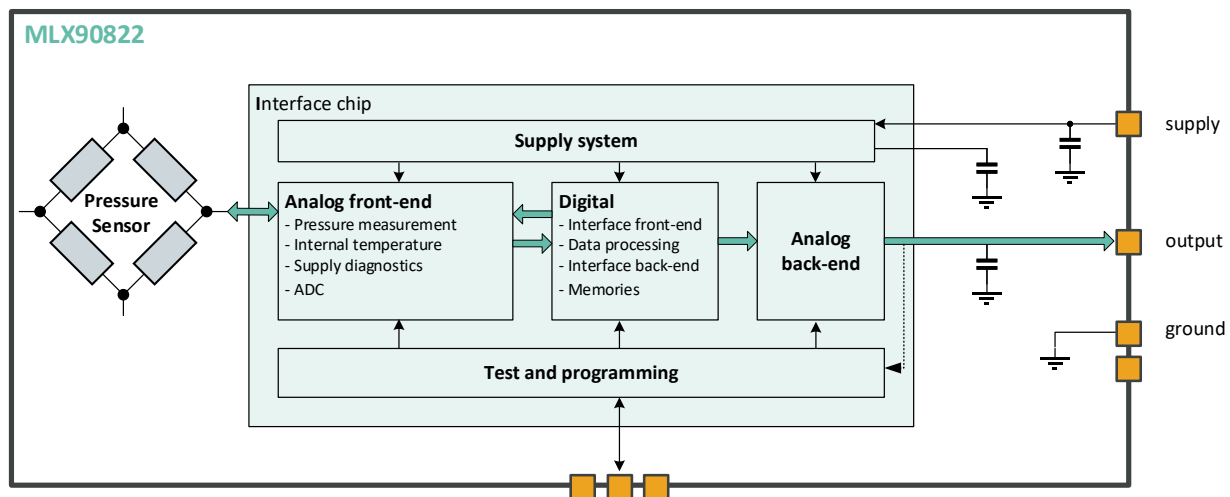

Figure 5: MLX90822 block diagram

## 11. Default Programmed Settings

The MLX90822 is calibrated at the final manufacturing test steps. During the calibration, settings are stored in the on chip EEPROM to define the pressure transfer curve.

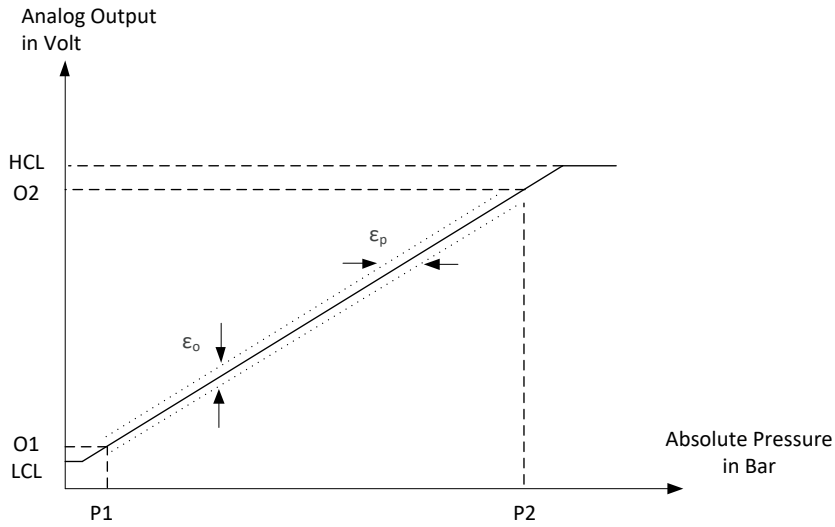

Figure 6: Pressure transfer function description at room temperature

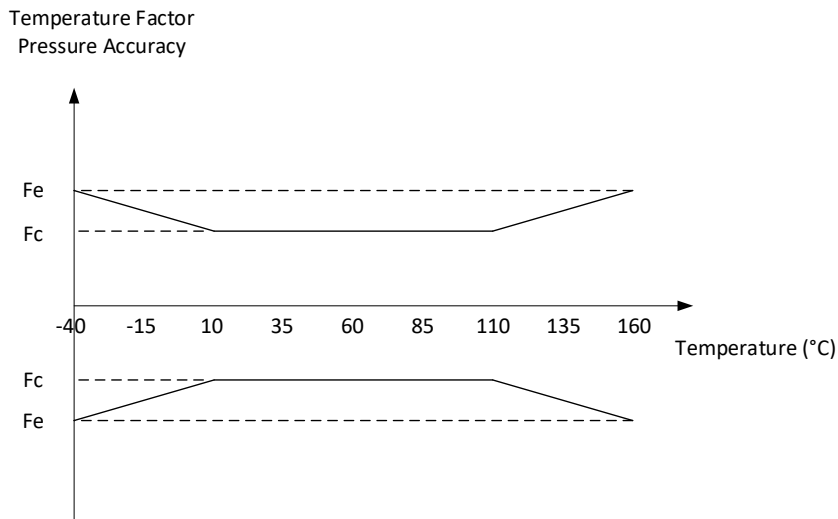

Figure 7: Pressure accuracy temperature factor



# MLX90822

Absolute Pressure Sensor with analog output  
Datasheet

## 11.1. MLX90822GXP-BAA-300

Transfer Curve Parameter	Symbol	Remarks	Value			Unit
Pressure 1	P1	See Figure 6: Pressure transfer function description at room temperature	0.1			Bar
Pressure 2	P2		1.15			Bar
Output 1	O1		0.5			V
Output 2	O2		4.5			V
Low clamping level	LCL		0.3			V
High clamping level	HCL		4.7			V
Pressure Accuracy Parameter	Symbol	Remarks	Min	Typ	Max	Unit
Output accuracy	$\epsilon_o$	Overall accuracy expressed as output value (FS range from 0.5V to 4.5V)	-20 -0.5		20 -0.5	mV %FS
Pressure accuracy	$\epsilon_p$	Overall accuracy expressed as pressure value	-5.25		5.25	mBar
Center temperature accuracy factor	Fc	See Figure 7: Pressure accuracy temperature factor			1	
Extended temperature accuracy factor	Fe				1.5	

Table 6: BAA-300 Default configuration

## 11.2. MLX90822GXP-BAA-304

Transfer Curve Parameter	Symbol	Remarks	Value			Unit
Pressure 1	P1	See Figure 6: Pressure transfer function description at room temperature	0.1			Bar
Pressure 2	P2		1.15			Bar
Output 1	O1		0.4			V
Output 2	O2		4.65			V
Low clamping level	LCL		0.3			V
High clamping level	HCL		4.7			V
Pressure Accuracy Parameter	Symbol	Remarks	Min	Typ	Max	Unit
Output accuracy	$\epsilon_o$	Overall accuracy expressed as output value (FS range from 0.5V to 4.5V)	-21 -0.5		21 -0.5	mV %FS
Pressure accuracy	$\epsilon_p$	Overall accuracy expressed as pressure value	-5.25		5.25	mBar
Center temperature accuracy factor	Fc	See Figure 7: Pressure accuracy temperature factor			1	
Extended temperature accuracy factor	Fe				1.5	

Table 7: BAA-304 Default configuration

# MLX90822

Absolute Pressure Sensor with analog output  
Datasheet

## 11.3. MLX90822GXP-BAB-301

Transfer Curve Parameter	Symbol	Remarks	Value			Unit
Pressure 1	P1	See Figure 6: Pressure transfer function description at room temperature	0.1			Bar
Pressure 2	P2		3			Bar
Output 1	O1		0.5			V
Output 2	O2		4.5			V
Low clamping level	LCL		0.3			V
High clamping level	HCL		4.7			V
Pressure Accuracy Parameter	Symbol	Remarks	Min	Typ	Max	Unit
Output accuracy	$\epsilon_o$	Overall accuracy expressed as output value (FS range from 0.5V to 4.5V)	-20 -0.5		20 -0.5	mV %FS
Pressure accuracy	$\epsilon_p$	Overall accuracy expressed as pressure value	-14.5		14.5	mBar
Center temperature accuracy factor	Fc	See Figure 7: Pressure accuracy temperature factor			1	
Extended temperature accuracy factor	Fe				1.25	

Table 8: BAB-301 Default configuration

## 11.4. MLX90822GXP-BAB-302

Transfer Curve Parameter	Symbol	Remarks	Value			Unit
Pressure 1	P1	See Figure 6: Pressure transfer function description at room temperature	0.1			Bar
Pressure 2	P2		4			Bar
Output 1	O1		0.5			V
Output 2	O2		4.5			V
Low clamping level	LCL		0.3			V
High clamping level	HCL		4.7			V
Pressure Accuracy Parameter	Symbol	Remarks	Min	Typ	Max	Unit
Output accuracy	$\epsilon_o$	Overall accuracy expressed as output value (FS range from 0.5V to 4.5V)	-20 -0.5		20 -0.5	mV %FS
Pressure accuracy	$\epsilon_p$	Overall accuracy expressed as pressure value	-19.5		19.5	mBar
Center temperature accuracy factor	Fc	See Figure 7: Pressure accuracy temperature factor			1	
Extended temperature accuracy factor	Fe				1.25	

Table 9: BAB-302 Default Configuration

## 12. Diagnostics

The MLX90822 has built in diagnostics which can flag fault conditions. This is done by having an output set to 0V or 5V, this is beyond the upper and lower clamp levels of a valid output signal. There are two groups. The first is the broken connection diagnostic which triggers when the device is connected incorrectly. The second group consists of the internal diagnostics, these are used to flag abnormal states during operation.

### 12.1. Broken Connection Diagnostics

Table 10 shows the output behavior of the MLX90822 if a connection is broken or incorrect.

GND	VDD	Analog out	Effect on output	Action after wrong connection
0V	5V	Pull-down or Pull-up	Normal operation	Normal operation
Disconnected	5V	Pull-down or Pull-up	Lower Fault Band for Pull-down Upper Fault Band for Pull-up	Normal operation
0V	Disconnected	Pull-down or Pull-up	Low Fault Band for Pull-down Upper Fault Band for Pull-up	Normal operation
0V	5V	Disconnected	Low Fault Band for Pull-down Upper Fault Band for Pull-up	Normal operation
0V	5V	0V	Low Fault Band	Normal operation
0V	5V	5V	Upper Fault Band	Normal operation

*Table 10: Broken connections*

### 12.2. Internal Diagnostics

The MLX90822 has several internal checks which monitor the status of the device. These checks or diagnostic sources can be enabled or disabled based on the sensor module requirements. It's possible to separately define some sources to appear as a Low Fault Band error and others as a High Fault Band. Table 11 shows the available diagnostic sources which can be programmed to result in either a high fault band output or low fault band output.

Bit	Error condition	Default settings
0	Supply voltage too high	Disabled
1	Supply voltage too low	Disabled
2	Internal error	Lower Fault Band
3	Broken pressure membrane	Lower Fault Band
4	Pressure parameter error	Lower Fault Band
5	Pressure output error	Lower Fault Band
6	Internal regulator out of range	Disabled

*Table 11: Diagnostic sources*

# MLX90822

Absolute Pressure Sensor with analog output  
Datasheet

## 13. Digital

The digital is built around a 16-bit microcontroller. It contains besides the processor also ROM, RAM and EEPROM and a set of user and system IO registers. Temperature compensation of the pressure signal and pressure linearization is handled by the microcontroller. For the pressure compensation there are EEPROM parameters allocated to be able to cover a large variety of calibration approaches.

Both for gain and offset of the pressure signal, there is a separate temperature dependency which is programmable up to a third order compensation. This is reflected in EEPROM parameters for the offset (O0, O1, O2 and O3) and for the gain (G0, G1, G2 and G3).

If required, the linearity of the pressure signal can also be compensated with a first order temperature dependency through EEPROM parameters L0 and L1.

## 14. Application Information

The MLX90822 has two GND pins, only one needs to be connected in the application.

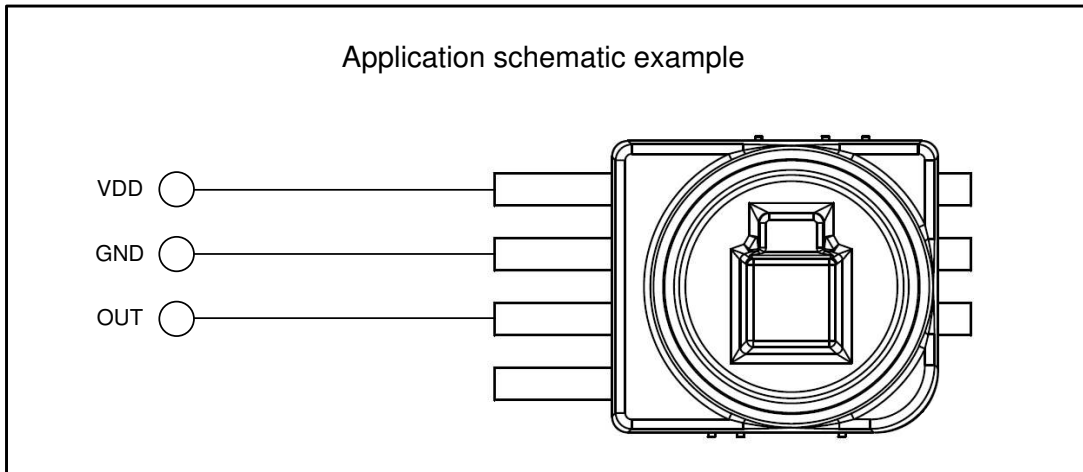

Figure 8: Basic application example with pin 3 as GND

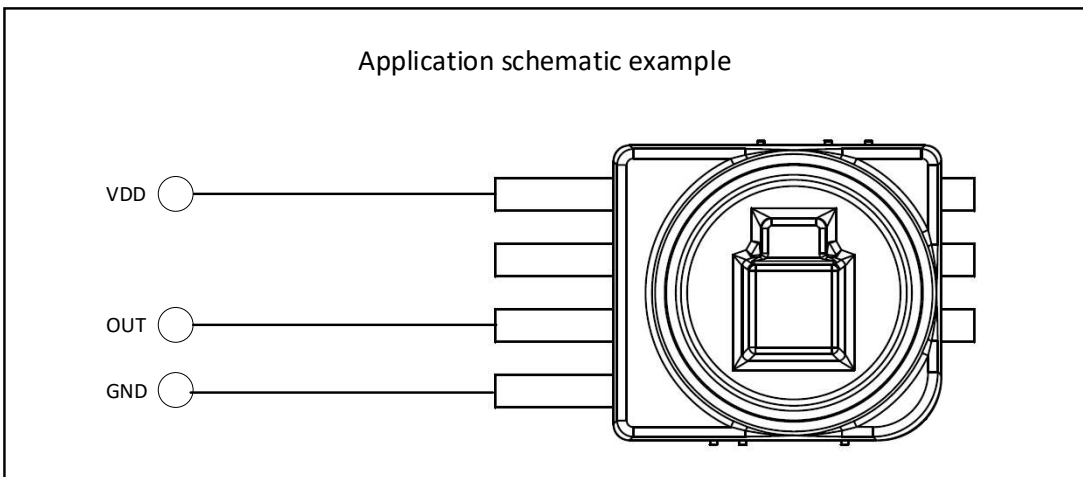

Figure 9: Basic application example with pin 1 as GND

## 15. Storage and Handling of Plastic Encapsulated ICs

Plastic encapsulated ICs shall be stored and handled according to their MSL categorization level (specified in the packing label) as per J-STD-033.

Electronic semiconductor products are sensitive to Electro Static Discharge (ESD). The component assembly shall be handled in EPA (Electrostatic Protected Area) as per ANSI S20.20

For more information refer to Melexis [Guidelines for storage and handling of plastic encapsulated ICs](#) <sup>(8)</sup>

## 16. Assembly of Encapsulated ICs

For Surface Mounted Devices (SMD, as defined according to JEDEC norms), the only applicable soldering method is reflow.

For Through Hole Devices (THD), the applicable soldering methods are reflow, wave, selective wave and robot point-to-point. THD lead pre-forming (cutting and/or bending) is applicable under strict compliance with Melexis [Guidelines for lead forming of SIP Hall Sensors](#) <sup>(8)</sup>.

Melexis products soldering on PCB should be conducted according to the requirements of IPC/JEDEC and J-STD-001. Solder quality acceptance should follow the requirements of IPC-A-610.

For PCB-less assembly refer to the relevant application notes <sup>(8)</sup> or contact Melexis.

Electrical resistance welding or laser welding can be applied to Melexis products in THD and specific PCB-less packages following the [Guidelines for welding of PCB-less devices](#) <sup>(8)</sup>.

Environmental protection of customer assembly with Melexis products for harsh media application, is applicable by means of coating, potting or overmolding considering restrictions listed in the relevant application notes <sup>(8)</sup>

For other specific process, contact Melexis via [www.melexis.com/technical-inquiry](http://www.melexis.com/technical-inquiry)

## 17. Environment and Sustainability

Melexis is contributing to global environmental conservation by promoting non-hazardous solutions. For more information on our environmental policy and declarations (RoHS, REACH...) visit [www.melexis.com/environmental-forms-and-declarations](http://www.melexis.com/environmental-forms-and-declarations)

---

<sup>8</sup> [www.melexis.com/ic-handling-and-assembly](http://www.melexis.com/ic-handling-and-assembly)

18. Package Information

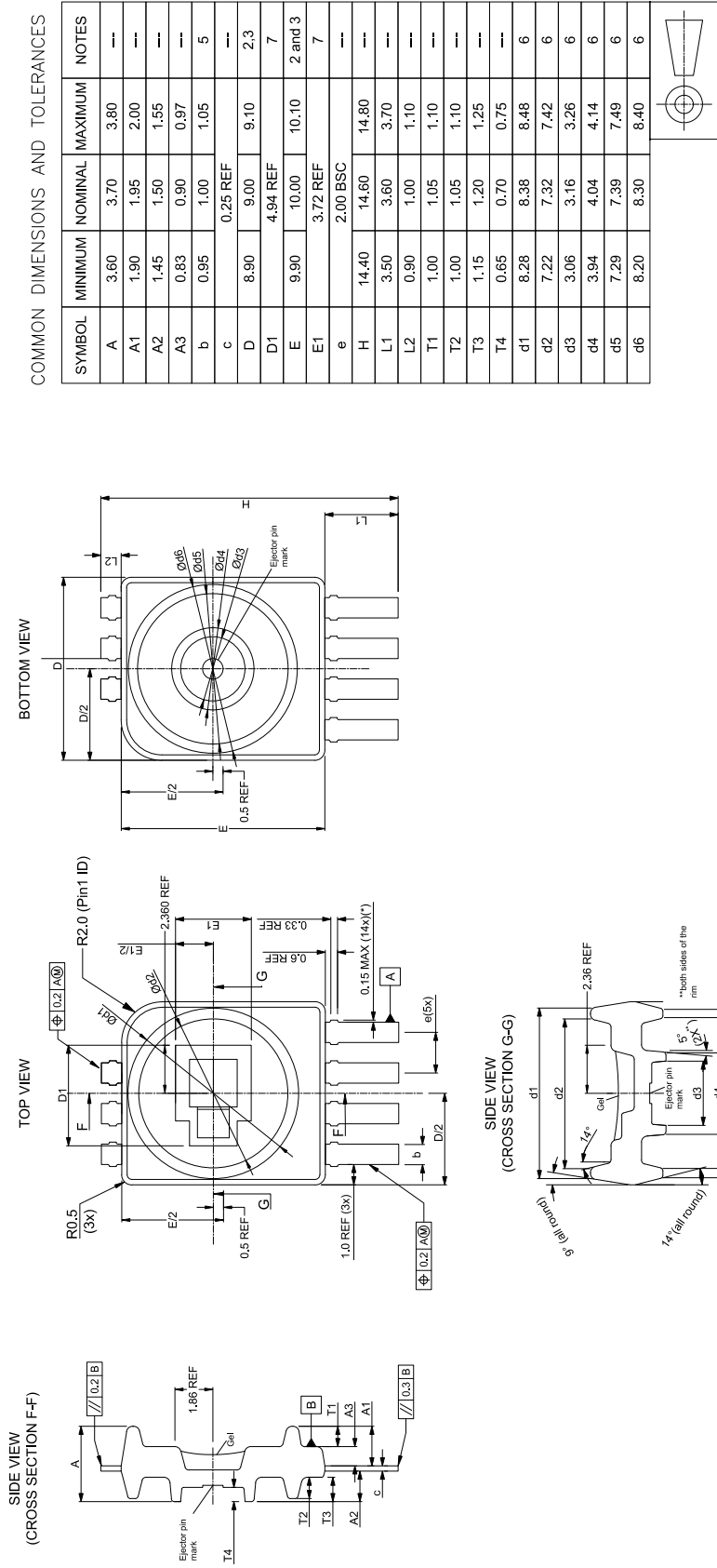

Note:

- ALL DIMENSIONS IN MILLIMETERS (mm) UNLESS NOTED OTHERWISE.
- PACKAGE DIMENSIONS "D", "E" AND "R2.0" DO NOT INCLUDE MOLD FLASHES, PROTRUSIONS OR GATE BURRS. CONTACT MELEXIS FOR SPECIFIC DESIGN RECOMMENDATIONS.
- PACKAGE TOP SURFACE MAY BE SMALLER THAN PACKAGE BOTTOM.
- SHINY SURFACE OUTLOOK DUE TO USE OF FILM.
- DIMENSION "b" DOES NOT INCLUDE DAMBARY PROTRUSION.
- MIN AND MAX VALUES DEPEND ON THE RADIUS OF THE RIM WHICH CAN VARY FROM POSITION TO POSITION.
- DIMENSIONS "D1" AND "E1" CORRESPOND TO THE GEL FILLED CAVITY. ANY MECHANICAL CONTACT WITHIN MINIMUM DIAMETER OF "d2" SHOULD BE AVOIDED AT ALL TIME. CONTACT MELEXIS FOR SPECIFIC DESIGN RECOMMENDATIONS.

Figure 10: MLX90822 package drawing

## 19. Disclaimer

*The content of this document is believed to be correct and accurate. However, the content of this document is furnished "as is" for informational use only and no representation, nor warranty is provided by Melexis about its accuracy, nor about the results of its implementation. Melexis assumes no responsibility or liability for any errors or inaccuracies that may appear in this document. Customer will follow the practices contained in this document under its sole responsibility. This documentation is in fact provided without warranty, term, or condition of any kind, either implied or expressed, including but not limited to warranties of merchantability, satisfactory quality, non-infringement, and fitness for purpose. Melexis, its employees and agents and its affiliates' and their employees and agents will not be responsible for any loss, however arising, from the use of, or reliance on this document. Notwithstanding the foregoing, contractual obligations expressly undertaken in writing by Melexis prevail over this disclaimer.*

*This document is subject to change without notice, and should not be construed as a commitment by Melexis. Therefore, before placing orders or prior to designing the product into a system, users or any third party should obtain the latest version of the relevant information.*

*Users or any third party must determine the suitability of the product described in this document for its application, including the level of reliability required and determine whether it is fit for a particular purpose.*

*This document as well as the product here described may be subject to export control regulations. Be aware that export might require a prior authorization from competent authorities. The product is not designed, authorized or warranted to be suitable in applications requiring extended temperature range and/or unusual environmental requirements. High reliability applications, such as medical life-support or life-sustaining equipment or avionics application are specifically excluded by Melexis. The product may not be used for the following applications subject to export control regulations: the development, production, processing, operation, maintenance, storage, recognition or proliferation of:*

- 1. chemical, biological or nuclear weapons, or for the development, production, maintenance or storage of missiles for such weapons;*
- 2. civil firearms, including spare parts or ammunition for such arms;*
- 3. defense related products, or other material for military use or for law enforcement;*
- 4. any applications that, alone or in combination with other goods, substances or organisms could cause serious harm to persons or goods and that can be used as a means of violence in an armed conflict or any similar violent situation.*

*No license nor any other right or interest is granted to any of Melexis' or third party's intellectual property rights.*

*If this document is marked "restricted" or with similar words, or if in any case the content of this document is to be reasonably understood as being confidential, the recipient of this document shall not communicate, nor disclose to any third party, any part of the document without Melexis' express written consent. The recipient shall take all necessary measures to apply and preserve the confidential character of the document. In particular, the recipient shall (i) hold document in confidence with at least the same degree of care by which it maintains the confidentiality of its own proprietary and confidential information, but no less than reasonable care; (ii) restrict the disclosure of the document solely to its employees for the purpose for which this document was received, on a strictly need to know basis and providing that such persons to whom the document is disclosed are bound by confidentiality terms substantially similar to those in this disclaimer; (iii) use the document only in connection with the purpose for which this document was received, and reproduce document only to the extent necessary for such purposes; (iv) not use the document for commercial purposes or to the detriment of Melexis or its customers. The confidentiality obligations set forth in this disclaimer will have indefinite duration and in any case they will be effective for no less than 10 years from the receipt of this document.*

*This disclaimer will be governed by and construed in accordance with Belgian law and any disputes relating to this disclaimer will be subject to the exclusive jurisdiction of the courts of Brussels, Belgium.*

*The invalidity or ineffectiveness of any of the provisions of this disclaimer does not affect the validity or effectiveness of the other provisions.*

*The previous versions of this document are repealed.*

*Melexis © - No part of this document may be reproduced without the prior written consent of Melexis. (2023)*

*IATF 16949 and ISO 14001 Certified*