

rev	ecn no	dr	date
A	V06-0148	LP	2006-04-24
B	V06-0558	LP	2006-06-21
C	V08-0190	HTB	2008-04-15
D	V09-0071	PK	2009-02-24
-	-	-	-

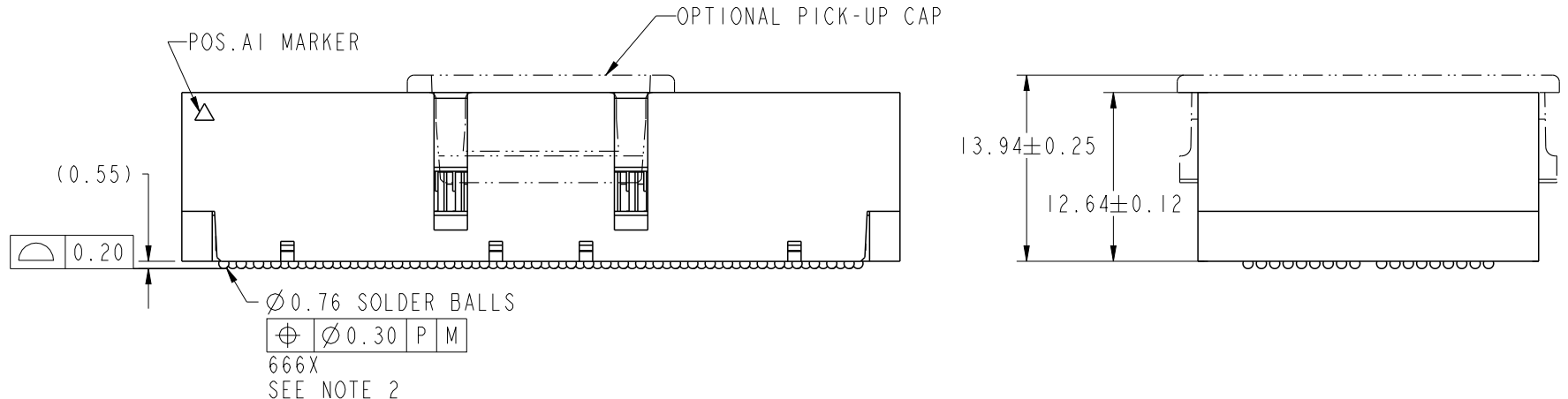

spec ref	-			dr	Bill Lin	2010/02/02	projection 	MM ←→	size	A4	scale	1:1	
tolerance std	TOLERANCES UNLESS OTHERWISE SPECIFIED			eng	Nickor Zuo	2011/06/15			ecn no	ELX-DG-003943-1			
ASME Y14.5				chr	Alex Cao	2011/06/24			rel level	Released			
surface	3.2	linear	0.X ±0.3	appr	Pei-Ming Zheng	2011/06/27	product family	GIG-Array			rev	E	
ASME Y14.5		angular	0° ±2°	www.fci.com		title	GIG-Array 13mm PLUG 296. POS. (LOW INSERTION FORCE TIP)			cat. no.	-	Product - Customer Drw	sheet 1 of 5
			0.XX ±0.10				dwg no	10060911					
			0.XXX ±0.050										

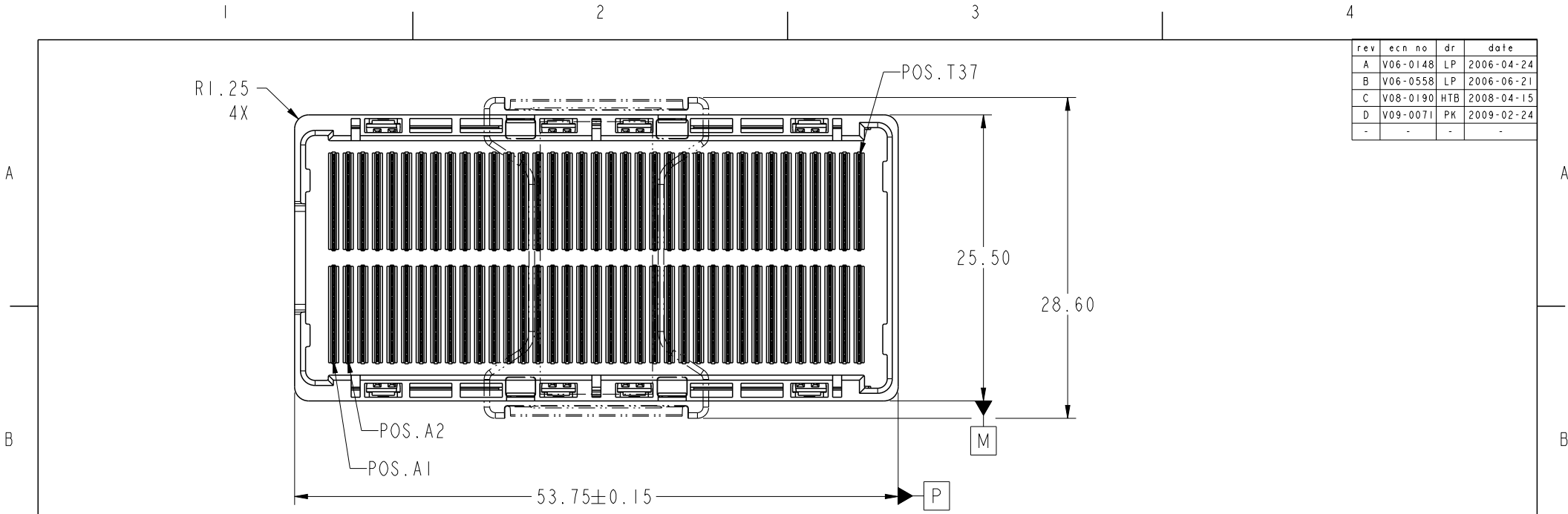

Copyright FCI.

ProjE File - REV C - 2009-06-09



Copyright FCI.

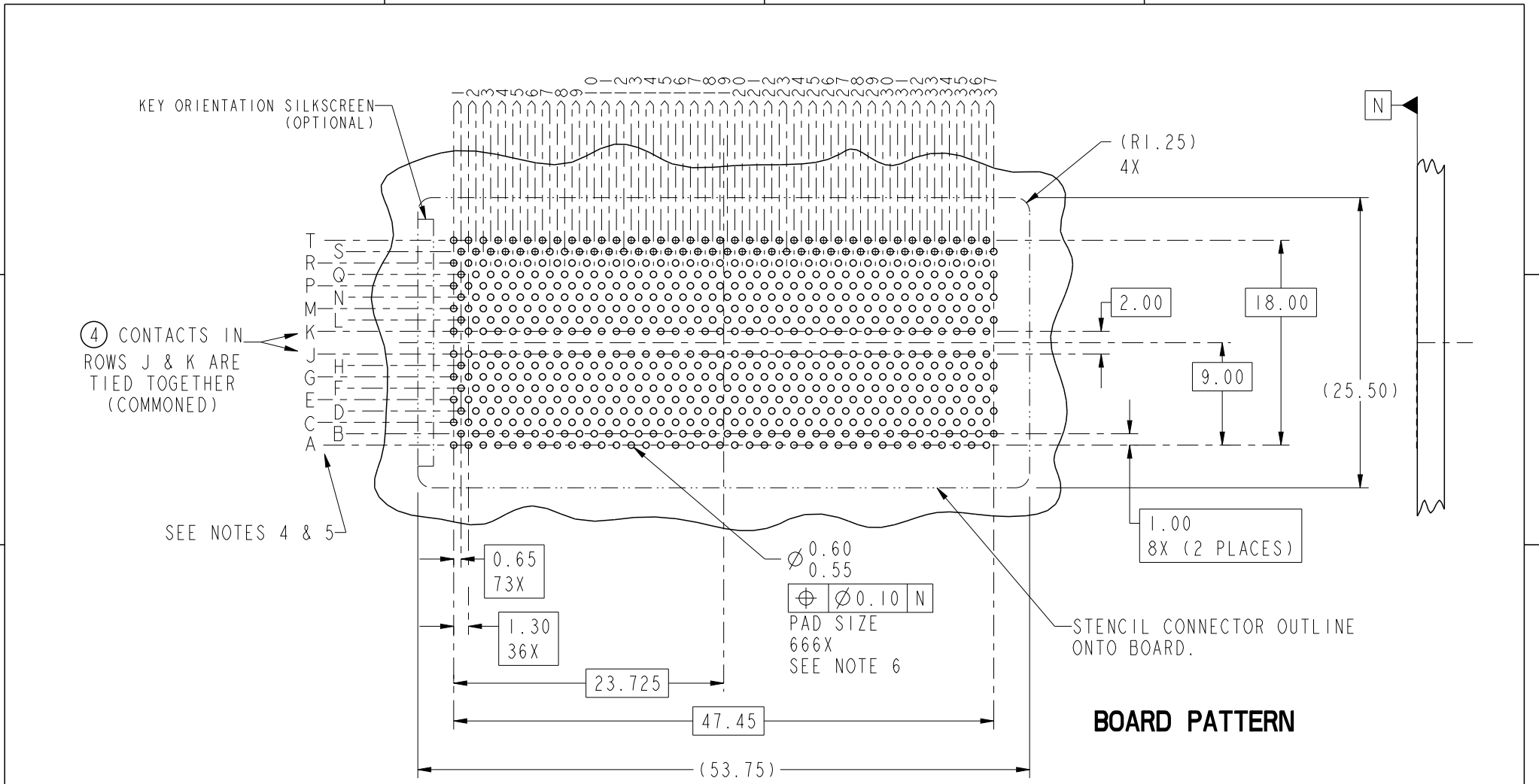

BOARD PATTERN

spec ref		-		dr	Bill Lin	2010/02/02	projection 	MM ←→	size	A4	scale	1:1
tolerance std	ASME Y14.5	TOLERANCES UNLESS OTHERWISE SPECIFIED		eng	Nickor Zuo	2011/06/15			ecn no	ELX-DG-003943-1		
				chr	Alex Cao	2011/06/24				rel level	Released	
surface		linear	0.X	±0.3		title GIG-Array 13mm PLUG 296. POS. (LOW INSERTION FORCE TIP)	product family GIG-Array	dwg no 10060911	rev E			
ASME Y14.5			0.XX	±0.10								
		0.XXX	±0.050									
		angular	0°	±2°	www.fci.com	cat. no.	-	Product - Customer Drw	sheet 2 of 5			

ProjE File - REV C - 2009-06-09

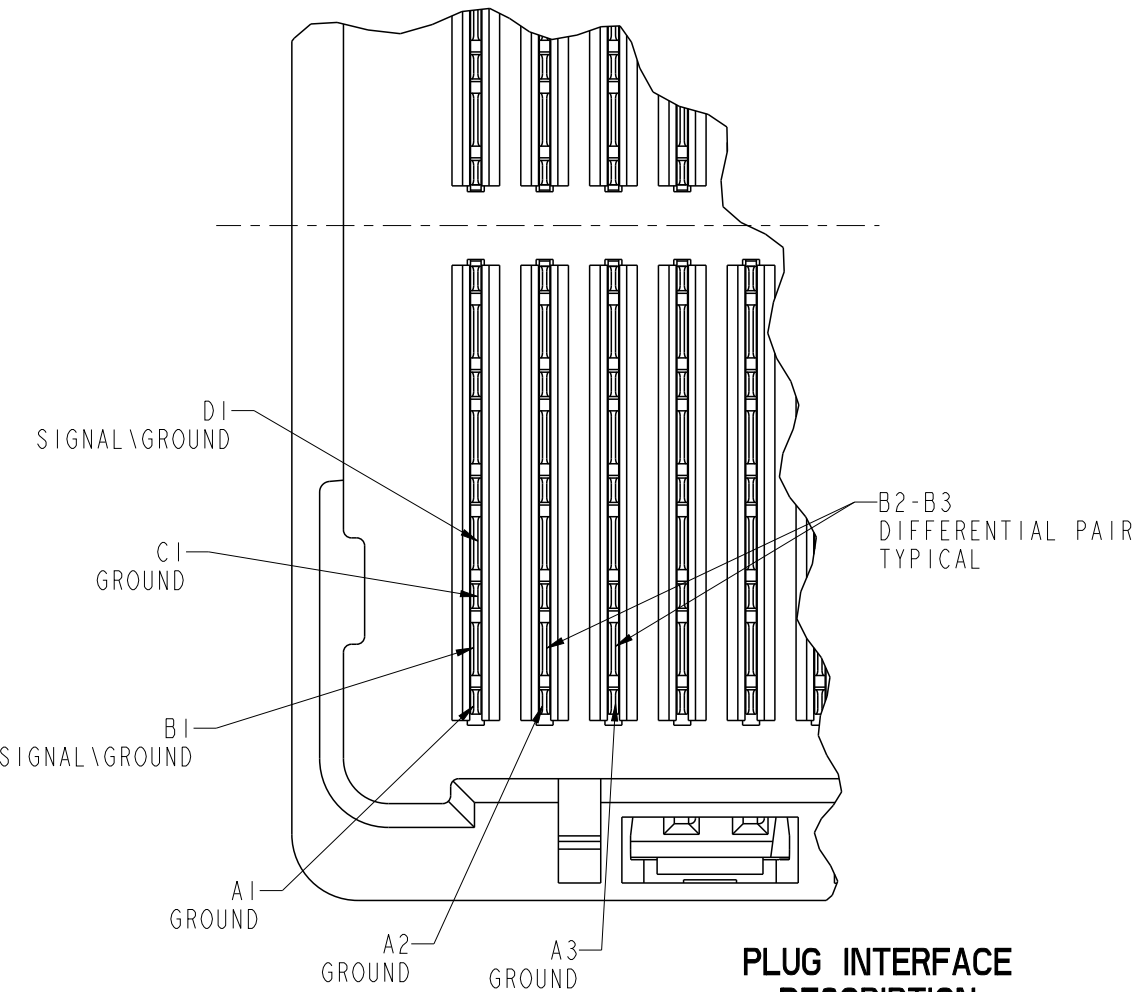

PLUG INTERFACE DESCRIPTION

spec ref		-		dr	Bill Lin	2010/02/02	projection 	MM 	size	A4	scale	1:1	
tolerance std	ASME Y14.5	TOLERANCES UNLESS OTHERWISE SPECIFIED		eng	Nickor Zuo	2011/06/15			ecn no	ELX-DG-003943-1			
				chr	Alex Cao	2011/06/24				rel level	Released		
-		-		appr	Pei-Ming Zheng	2011/06/27	product family		GIG-Array				
surface	3.2	linear	0.X	±0.3		title	GIG-Array 13mm PLUG 296. POS. (LOW INSERTION FORCE TIP)		dwg no	10060911		rev	E
			0.XX	±0.10									
ASME Y14.5		angular	0°	±2°	www.fci.com	cat. no.	-	Product - Customer Drw		sheet 3 of 5			

PrdE File - REV C - 2009-06-09

FLAT AREA FOR PICK-UP CAP

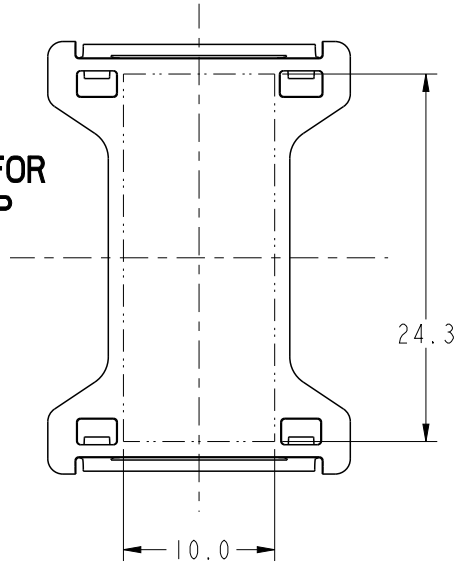

END VIEW OF MATED CONNECTORS

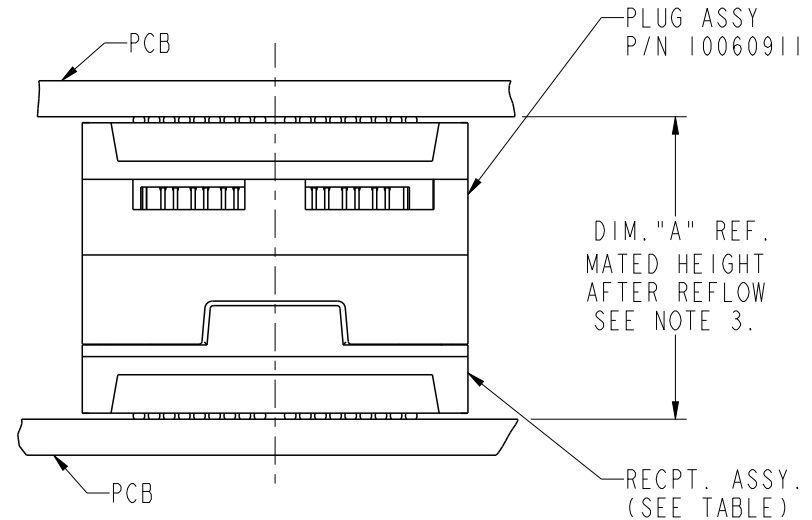

DIM. "A"	RECPT. ASSY. P/N
28	55733
18	55701



Copyright FCI.

spec ref -		dr Bill Lin	2010/02/02	projection 	MM ←→	size A4	scale 1:1
tolerance std ASME Y14.5	TOLERANCES UNLESS OTHERWISE SPECIFIED		eng Nickor Zuo			2011/06/15	ecn no ELX-DG-003943-1
			chr Alex Cao			2011/06/24	
-		appr Pei-Ming Zheng	2011/06/27	product family GIG-Array	rel level Released		
surface $\sqrt{3.2}$ ASME Y14.5	linear	0.X	± 0.3	 www.fci.com	title GIG-Array 13mm PLUG 296. POS. (LOW INSERTION FORCE TIP)	dwg no 10060911	rev E
		0.XX	± 0.10				
	angular	0°	$\pm 2^\circ$	cat. no. -	Product - Customer Drw	sheet 4 of 5	

PRODUCT NUMBER	SOLDER BALL COMPOSITION	CONTACT PLATING PERFORMANCE LEVEL
10060911-001	STANDARD (EUTECTIC)	PERFORMANCE-BASED PLATING, QUALIFIED TO MEET THE REQUIREMENTS OF FCI PRODUCT SPECIFICATION GS-12-192, INCLUDING TELCORDIA CENTRAL OFFICE
10060911-001LF	LEADFREE	
10060911-201	STANDARD (EUTECTIC)	Au over Ni
10060911-201LF	LEADFREE	

NOTES:

- ① MATERIAL:
HOUSING: LCP
CONTACT: COPPER ALLOY
PLATING (CONTACT): Au OVER Ni.
UL RATING: 94 V-0
- ② SOLDER BALLS WILL NOT BE PERFECT SPHERICAL SHAPE DUE TO REFLOW ATTACHMENT.
- ③ MATED HEIGHT EFFECTED BY CUSTOMERS' PCB PAD SIZE, PLATING, SOLDER REFLOW PROFILE & SOLDER PASTE.
- ④ CONTACTS IN ROWS A,C,E,G,J,K,M,P,R AND T ARE SINGLE BEAM CONTACTS, TYPICALLY USED AS GROUND PINS. (NOTE: CONTACTS IN ROWS J & K ARE TIED TOGETHER [COMMONED])
- ⑤ CONTACTS IN ROWS B,D,F,H,L,N,Q AND S ARE DUAL BEAM CONTACTS, TYPICALLY USED AS SIGNAL PINS.
- ⑥ SPECIFIED POSITIONAL TOLERANCE DEFINES PAD TO PAD LOCATION WITHIN LAND PATTERN. POSITIONAL TOLERANCE OF LAND PATTERN TO FUDICIAL MARKS OR PCB DATUMS SHALL BE DEFINED BY CUSTOMER. FOR RECOMMENDED PRODUCT APPLICATION AND PCB DESIGN DETAILS, SEE DOC. NO. GS-20-016.

NOTES CONTINUED

- ⑦ SPECIFIED POSITIONAL TOLERANCE DEFINES PAD TO PAD LOCATION WITHIN LAND PATTERN. POSITIONAL TOLERANCE OF LAND PATTERN TO FUDICIAL MARKS OR PCB DATUMS SHALL BE DEFINED BY CUSTOMER. FOR RECOMMENDED PRODUCT APPLICATION AND PCB DESIGN DETAILS, SEE DOC. NO. GS-20-016.
- ⑧ FOR PROPER APPLICATION FOLLOW FCI APPLICATION SPECIFICATION GS-20-033 LEADFREE SOLDER BALLS WILL NOT SOLDER PROPERLY IN A LEADED SOLDER PROCESS DUE TO A HIGHER REFLOW TEMPERATURE, LEADFREE PRODUCT IS THEREFORE NOT BACKWARDS COMPATIBLE WITH LEADED OR SOME SOLDERING APPLICATIONS. REFERENCE FCI APPLICATION SPECIFICATION.



Copyright FCI.

spec ref	-	dr	Bill Lin	2010/02/02	projection 	MM 	size	A4	scale	1:1	
tolerance std	TOLERANCES UNLESS OTHERWISE SPECIFIED	eng	Nickor Zuo	2011/06/15			product family	GIG-Array	ecn no	ELX-DG-003943-1	
ASME Y14.5		chr	Alex Cao	2011/06/24				rel level	Released		
surface $\sqrt{3.2}$	linear	appr	Pei-Ming Zheng	2011/06/27	title	GIG-Array 13mm PLUG 296. POS. (LOW INSERTION FORCE TIP)	dwg no	10060911	rev	E	
ASME Y14.5	angular	www.fci.com		cat. no.							-