

USB 2.0 - ESD & Overcurrent Protection

Solution Products



MF-NSMF075-2



CG0603MLC-05LE

Objective

Universal Serial Bus (USB) 2.0 ports provide up to 480 Mbps data transfer rates and 5 V power at up to 500 mA. As a hot-pluggable interface, it typically requires protection against ESD and short circuits. This solution provides this protection.

Solution

- 1 Multifuse[®] PPTC: MF-NSMF075-2
- 3 ChipGuard[®] ESD Suppressors: CG0603MLC-05LE

Compliance

- USB 2.0
- UL60950
- IEC 61000-4-2 Level 4 (8 kV / 15 kV)

Alternate Recommendations

Other PortNote[®] Solutions:

- USB: USB 3.0 - ESD & Overcurrent Protection

Benefit

This solution provides USB 2.0 ports with compatible protection without impairing the transmission of power or data.

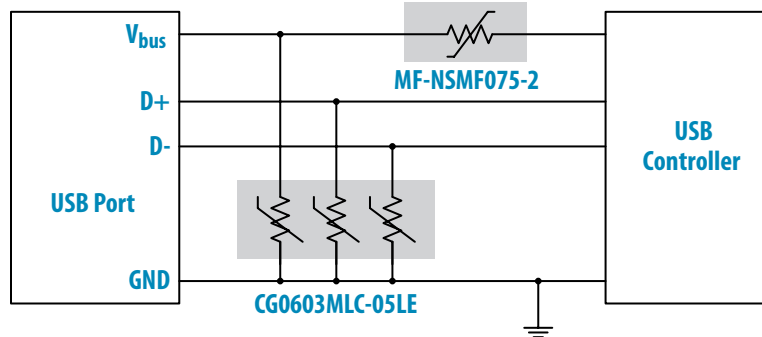

The schematic above illustrates the application protection and does not constitute the complete circuit design. Customers should verify actual device performance in their specific applications.

Design Kit



PN-DESIGNKIT-3