

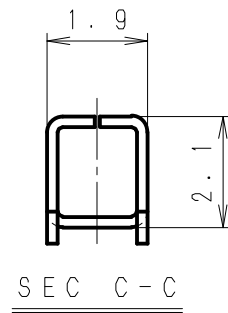

第三角法
3rd ANGLE PROJECTION

単位: mm
UNIT: mm
注) 図面を実測しないこと
NOTES) DO NOT SCALE

図番 DRAWING No.
JC-0622-06Z

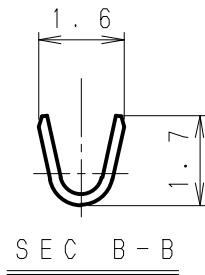
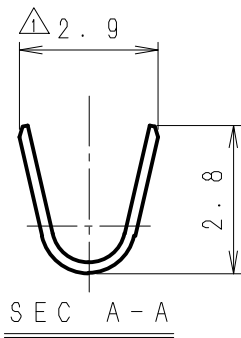
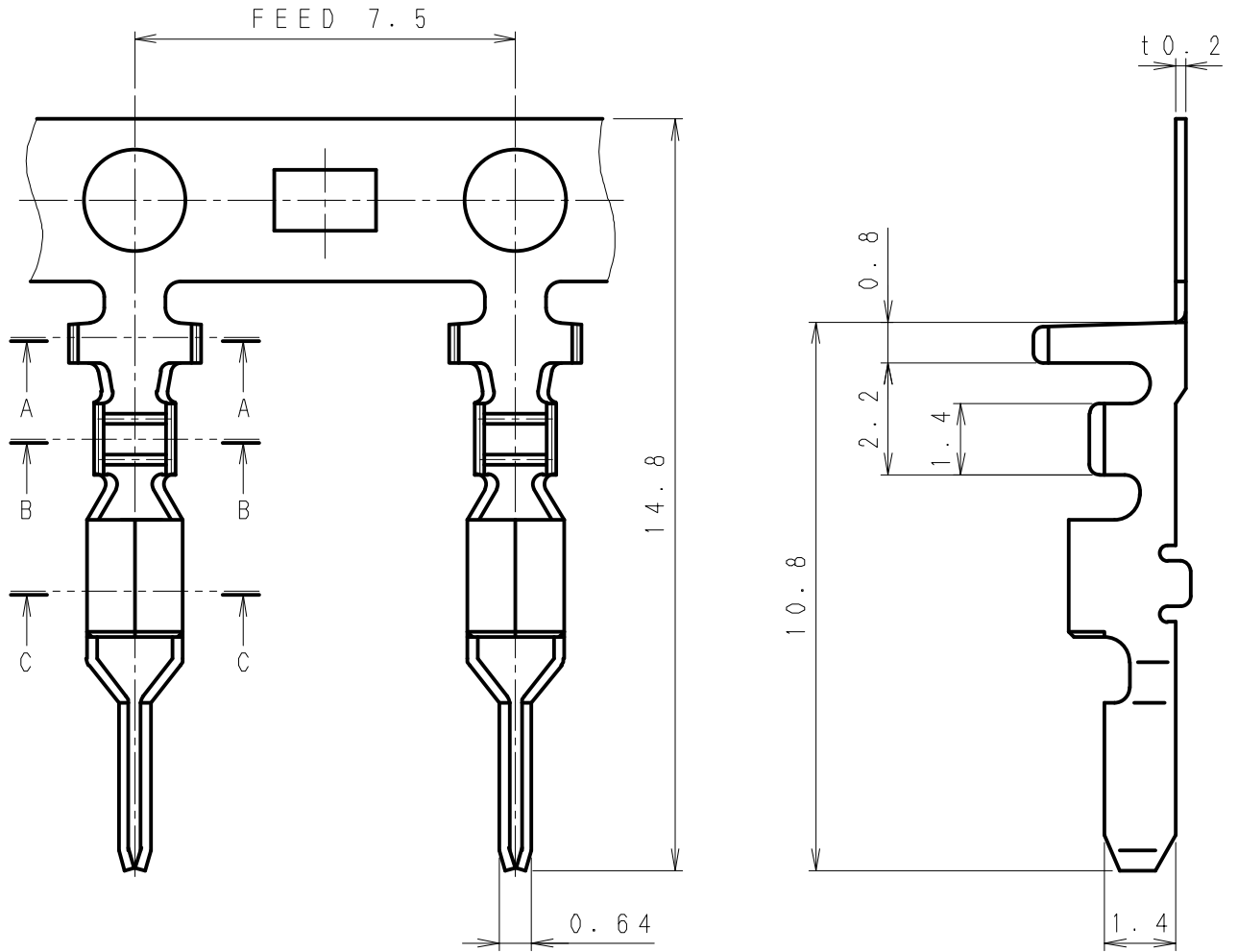

△6	. .								
△5	. .								
△4	. .								
△3	. .				725411-2MAC	リン青銅系 Phosphor Bronze Type	スズメッキ材 Pre-tin Plated	AWG#22~#28	MAX φ1.7
△2	. .				製品番号 PRODUCT No.	材 料 MATERIAL	表面処理 FINISH	適用電線 WIRE SIZE	被覆外径 INSULATION DIA
△1	13. 9. 10	誤記訂正 Error correction	清水	草野					
記号 No.	年月日 DATE	変更記事 REVISION RECORD	設計 DESIGN	承認 APP	製品名 NAME		ピンコンタクト Pin Contact		
承認 APPROVED Y. Horiuchi		確認 CHECKED K. Kusano		一般公差 TOLERANCE ±0.3	尺度 SCALE 7/1	図番 DRAWING No. JC-0622-06Z			
設計 DESIGN K. Yokoyama		製図 DRAWING K. Yokoyama		 JAPAN AUTOMATIC MACHINE CO., LTD.					