

PART NAME: KNOB

SCALE: 1:1

DATE: 6/20/11

DR. BY: JAM



DESIGNERS & MANUFACTURERS
OF KNOBS, HANDLE ENDS, CAPS &
CUSTOM PLASTIC COMPONENTS

P/N 1506-K

THIS DRAWING IS THE PROPERTY OF DAVIES MOLDING COMPANY, IS SUBMITTED SOLELY AS A DESIGN OR ENGINEERING PROJECT.
WE ACCEPT NO RESPONSIBILITY WHATSOEVER FOR THE PRACTICAL APPLICATION OF THE PIECES MADE TO THIS DESIGN.

MOLD #	1505/1506/2813
CAVITY	1506
CORE	1506
PIN	1506-J
INSERT	11216 (SPRING)

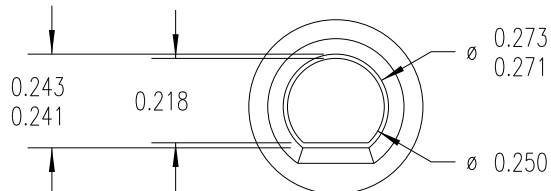
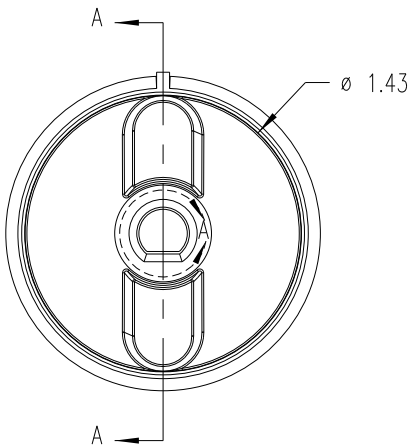
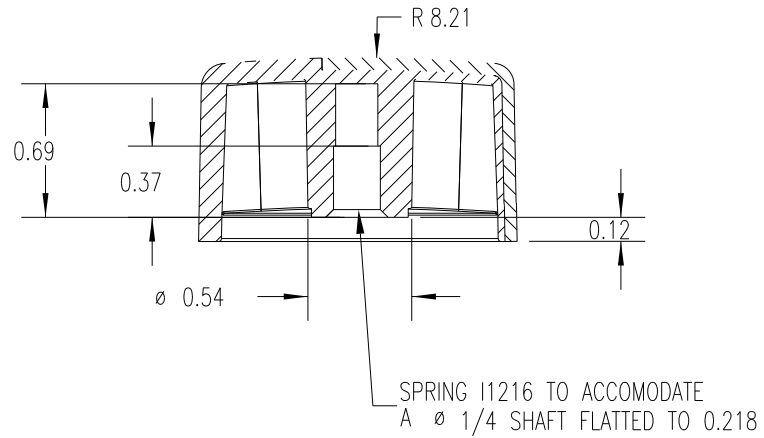
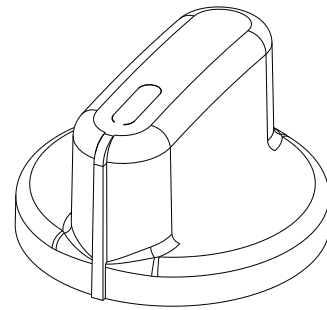
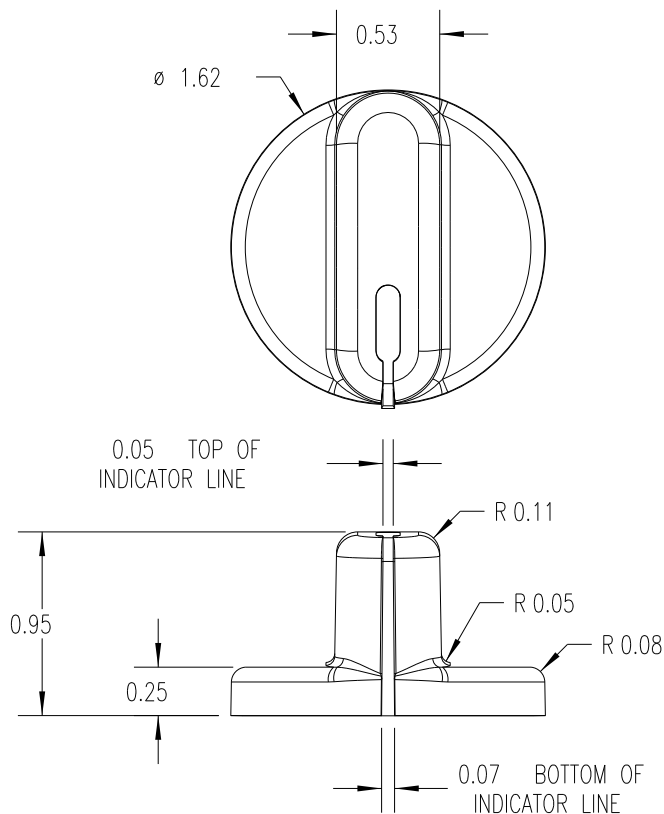

DETAIL A
SCALE 2 : 1
(MOLDED HOLE)

MATERIAL: SUBSTRATE: POLYPROPYLENE (CLD)
COLOR: WHITE (PC23083)
MATERIAL: OVERMOLD : TPE (TPE3)
COLOR: BLACK

TOLERANCES: UNLESS OTHERWISE SPECIFIED	DO NOT SCALE DRAWING			
DECIMALS: X.XXX ± .005 X.XX ± .015	MM: X.XX ± 0.15MM X.X ± 0.4MM	-	WAS SK1506-18	JAM 6/20/11
FRACTIONS ± 1/64	ANG. ± 1°	CHANGES		