

Verpackt im Gurt in Anlehnung an DIN IEC 60286-3
 Tape on Reel Packaging according to DIN IEC 60286-3
 Verpackungseinheit: 740 Stück
 Packaging unit: 740 pcs

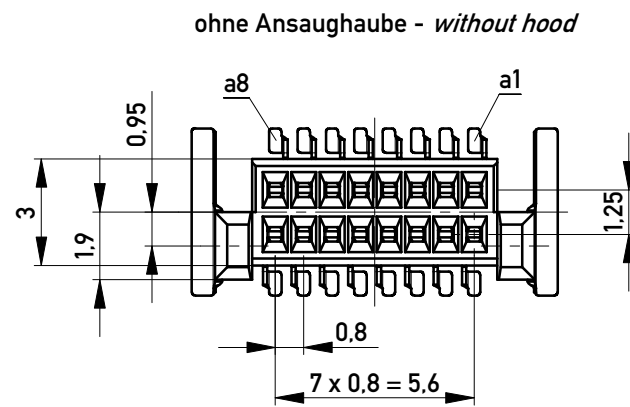

ohne Ansaughaube - without hood

ohne Ansaughaube - without hood

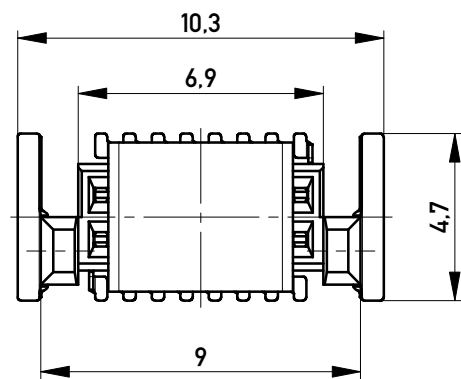
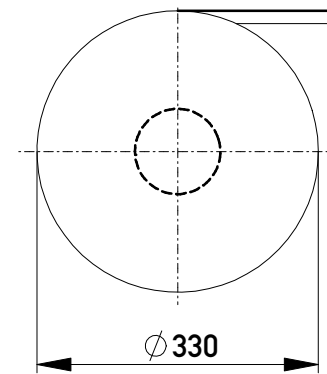
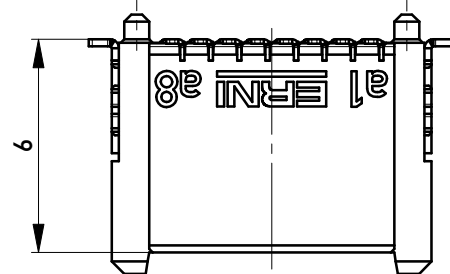

Abspulrichtung - Reel off Direction →

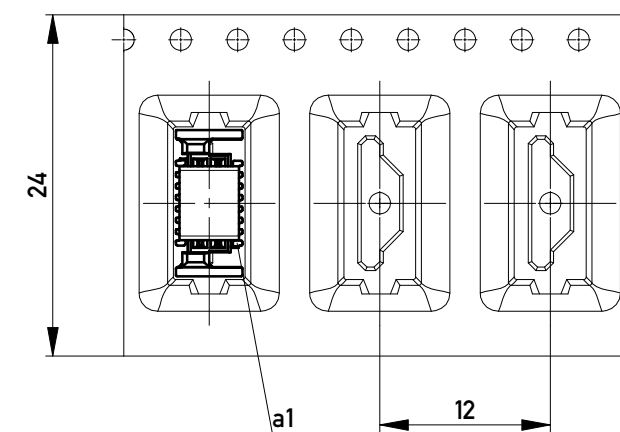

Anforderungsstufe 1
 Performance Level 1

Kontaktbereich vergoldet
 Mating Area gold plating

Anschlussbereich verzinkt 4-6 µm
 Terminal Area 4-6 µm tin plating

Koplanarität der Anschlüsse ≤ 0,1 mm
 Coplanarity Area of Termination ≤ 0,1 mm

Leiterplatten-Layout Vorschlag für SMT
 PCB-Layout Proposal for SMT

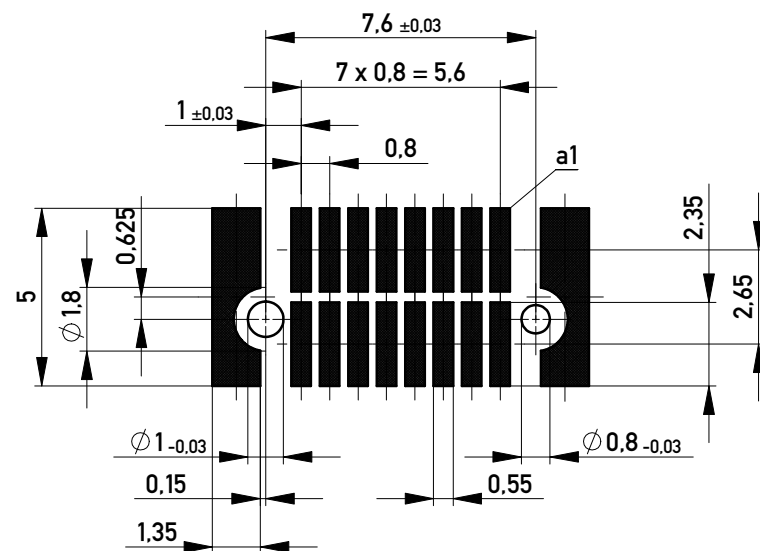

Information:	Tolerances	 All Dimensions in mm	Scale	5:1
	All rights reserved. Only for Information. To ensure that this is the latest version of this drawing, please contact one of the ERNI companies before using.		Designation 0,8 DRC-B, F 6mm, 16 polig 0,8 DRC-B, F 6mm, 16 pin	
Subject to modification without prior notice. Drawing will not be updated.		 www.ERNI.com	454925	
e	28.06.2016		Class DRCB	
Index	Date	i A3		

Copyright by ERNI Production GmbH & Co. KG
 Proprietary notice pursuant to ISO 16016 to be observed.