

EiceDRIVER™

High voltage gate driver IC

Evaluation Board

Application Note

EVAL_1ED020112-B2

Application Note

Revision 1.0, 2013-07-26

Edition 2013-07-26

**Published by
Infineon Technologies AG
81726 Munich, Germany**

**© 2013 Infineon Technologies AG
All Rights Reserved.**

LEGAL DISCLAIMER

THE INFORMATION GIVEN IN THIS APPLICATION NOTE IS GIVEN AS A HINT FOR THE IMPLEMENTATION OF THE INFINEON TECHNOLOGIES COMPONENT ONLY AND SHALL NOT BE REGARDED AS ANY DESCRIPTION OR WARRANTY OF A CERTAIN FUNCTIONALITY, CONDITION OR QUALITY OF THE INFINEON TECHNOLOGIES COMPONENT. THE RECIPIENT OF THIS APPLICATION NOTE MUST VERIFY ANY FUNCTION DESCRIBED HEREIN IN THE REAL APPLICATION. INFINEON TECHNOLOGIES HEREBY DISCLAIMS ANY AND ALL WARRANTIES AND LIABILITIES OF ANY KIND (INCLUDING WITHOUT LIMITATION WARRANTIES OF NON-INFRINGEMENT OF INTELLECTUAL PROPERTY RIGHTS OF ANY THIRD PARTY) WITH RESPECT TO ANY AND ALL INFORMATION GIVEN IN THIS APPLICATION NOTE.

Information

For further information on technology, delivery terms and conditions and prices, please contact the nearest Infineon Technologies Office (www.infineon.com).

Warnings

Due to technical requirements, components may contain dangerous substances. For information on the types in question, please contact the nearest Infineon Technologies Office.

Infineon Technologies components may be used in life-support devices or systems only with the express written approval of Infineon Technologies, if a failure of such components can reasonably be expected to cause the failure of that life-support device or system or to affect the safety or effectiveness of that device or system. Life support devices or systems are intended to be implanted in the human body or to support and/or maintain and sustain and/or protect human life. If they fail, it is reasonable to assume that the health of the user or other persons may be endangered.



Revision History: 2013-07 Rev.1.0

Page or Item	Subjects (major changes since last revision)
--------------	--

Previous Version: 1.0

Trademarks of Infineon Technologies AG

AURIX™, C166™, CanPAK™, CIPOS™, CIPURSE™, EconoPACK™, CoolMOS™, CoolSET™, CORECONTROL™, CROSSAVE™, DAVE™, DI-POL™, EasyPIM™, EconoBRIDGE™, EconoDUAL™, EconoPIM™, EconoPACK™, EiceDRIVER™, eupec™, FCOS™, HITFET™, HybridPACK™, I²RF™, ISOFACE™, IsoPACK™, MIPAQ™, ModSTACK™, my-d™, NovalithIC™, OptiMOS™, ORIGA™, POWERCODE™, PRIMARION™, PrimePACK™, PrimeSTACK™, PRO-SIL™, PROFET™, RASIC™, ReverSave™, SatRIC™, SIEGET™, SINDRION™, SIPMOS™, SmartLEWIS™, SOLID FLASH™, TEMPFET™, thinQ!™, TRENCHSTOP™, TriCore™.

Other Trademarks

Advance Design System™ (ADS) of Agilent Technologies, AMBA™, ARM™, MULTI-ICE™, KEIL™, PRIMECELL™, REALVIEW™, THUMB™, μ Vision™ of ARM Limited, UK. AUTOSAR™ is licensed by AUTOSAR development partnership. Bluetooth™ of Bluetooth SIG Inc. CAT-iq™ of DECT Forum. COLOSSUS™, FirstGPS™ of Trimble Navigation Ltd. EMV™ of EMVCo, LLC (Visa Holdings Inc.). EPCOS™ of Epcos AG. FLEXGO™ of Microsoft Corporation. FlexRay™ is licensed by FlexRay Consortium. HYPERTERMINAL™ of Hilgraeve Incorporated. IEC™ of Commission Electrotechnique Internationale. IrDA™ of Infrared Data Association Corporation. ISO™ of INTERNATIONAL ORGANIZATION FOR STANDARDIZATION. MATLAB™ of MathWorks, Inc. MAXIM™ of Maxim Integrated Products, Inc. MICROTEC™, NUCLEUS™ of Mentor Graphics Corporation. MIPI™ of MIPI Alliance, Inc. MIPS™ of MIPS Technologies, Inc., USA. muRata™ of MURATA MANUFACTURING CO., MICROWAVE OFFICE™ (MWO) of Applied Wave Research Inc., OmniVision™ of OmniVision Technologies, Inc. Openwave™ Openwave Systems Inc. RED HAT™ Red Hat, Inc. RFMD™ RF Micro Devices, Inc. SIRIUS™ of Sirius Satellite Radio Inc. SOLARIS™ of Sun Microsystems, Inc. SPANSION™ of Spansion LLC Ltd. Symbian™ of Symbian Software Limited. TAIYO YUDEN™ of Taiyo Yuden Co. TEAKLITE™ of CEVA, Inc. TEKTRONIX™ of Tektronix Inc. TOKO™ of TOKO KABUSHIKI KAISHA TA. UNIX™ of X/Open Company Limited. VERILOG™, PALLADIUM™ of Cadence Design Systems, Inc. VLYNQ™ of Texas Instruments Incorporated. VXWORKS™, WIND RIVER™ of WIND RIVER SYSTEMS, INC. ZETEX™ of Diodes Zetex Limited.

Last Trademarks Update 2011-11-11

Table of Contents

1	Introduction	5
2	Design feature	6
2.1	Main features.....	6
2.2	Key data	7
2.3	Pin assignment.....	8
2.4	IGBT Module EasyPACK 1B FS25R12W1T4_B11	8
3	Electrical features	9
3.1	Supply voltages +5V and +15V	9
3.2	Under voltage lockout	9
3.3	VCEsat monitoring for short circuit detection	9
3.4	Active Miller clamping	10
3.5	IGBT turn - on / off.....	10
3.6	DC-Link capacitor.....	12
3.7	Input PWM-Signals.....	12
4	Schematic and Layout	14
4.1	Schematic.....	14
4.2	Layout.....	17
4.2.1	Creepage distance	17
4.2.2	Layout top.....	17
4.2.3	Layout bottom.....	17
4.2.4	Top place.....	18
4.3	Bill of material	19

Warnings



The described board is an evaluation board dedicated for laboratory environment only. It operates at high voltages. This board must be operated by qualified, skilled personnel familiar with all applicable safety standards.

1 Introduction

The gate driver evaluation board EVAL_1ED020I12-B2 was developed to show the functionalities and key features of the Infineon IGBT gate driver 1ED020I12-B2 (applied also to 1ED020I12-F2).

The board is available from Infineon in sampling quantities. The properties of this part are described in the datasheet chapter of this document, whereas the remaining paragraphs provide information intended to enable the customer to copy, modify and qualify the design for production, according to their own specific requirements.

The design of the EVAL_1ED020I12-B2 was performed with respect to the environmental conditions described in this document. The design was tested as described in this document, but not qualified regarding manufacturing, lifetime or over the full ambient operating conditions.

The boards provided by Infineon are subjected to functional testing only.

Due to their purpose Evaluation Boards are not subjected to the same procedures regarding Returned Material Analysis (RMA), Process Change Notification (PCN) and Product Discontinuation (PD) as regular products. These Evaluation Boards are used for development support only and should not be used as reference design for volume production.

See Legal Disclaimer and Warnings for further restrictions on Infineons warranty and liability.

2 Design feature

This chapter provides an overview of the main features, key data, pin assignments and mechanical dimensions

2.1 Main features

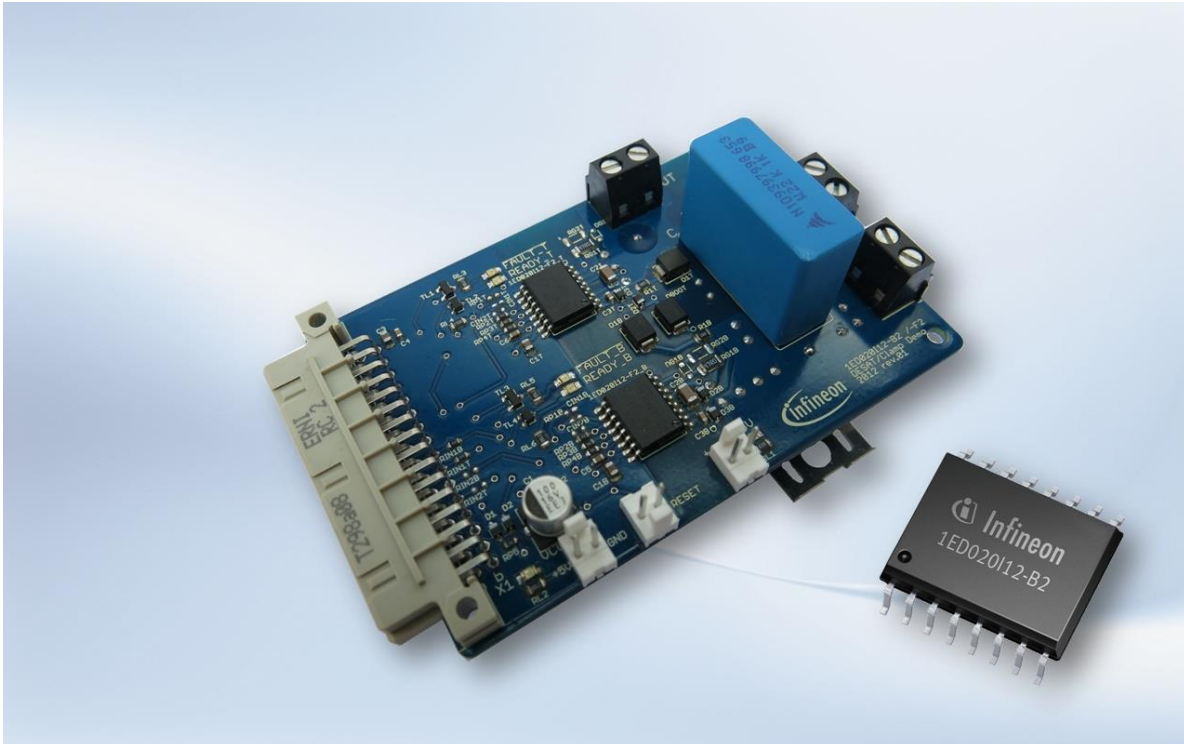

Figure 2-1 top view of the EVAL_1ED020I12-B2

The EVAL_1ED020I12-B2 contains two IGBT gate drivers 1ED020I12-B2 in a half bridge configuration and an IGBT module FS25R12W1T4_B11 where only two IGBTs are connected.

The evaluation board provides the following main features

- Galvanic isolation by the coreless transformer technology of the Infineon gate driver. The gate 1ED020I12-B2 is suitable for basic isolation
- Isolation inside the half bridge by defined creepage
- Short circuit protection
- Under voltage lock out
- Active miller clamp
- Bootstrap functionality for high side IGBT
- Connector for 5V digital supply, 15V supply, Reset, High voltage supply, external load
- Status LED for 5V supply, 15V supply, ready and fault separated for high- and lowside driver
- DC link capacitor

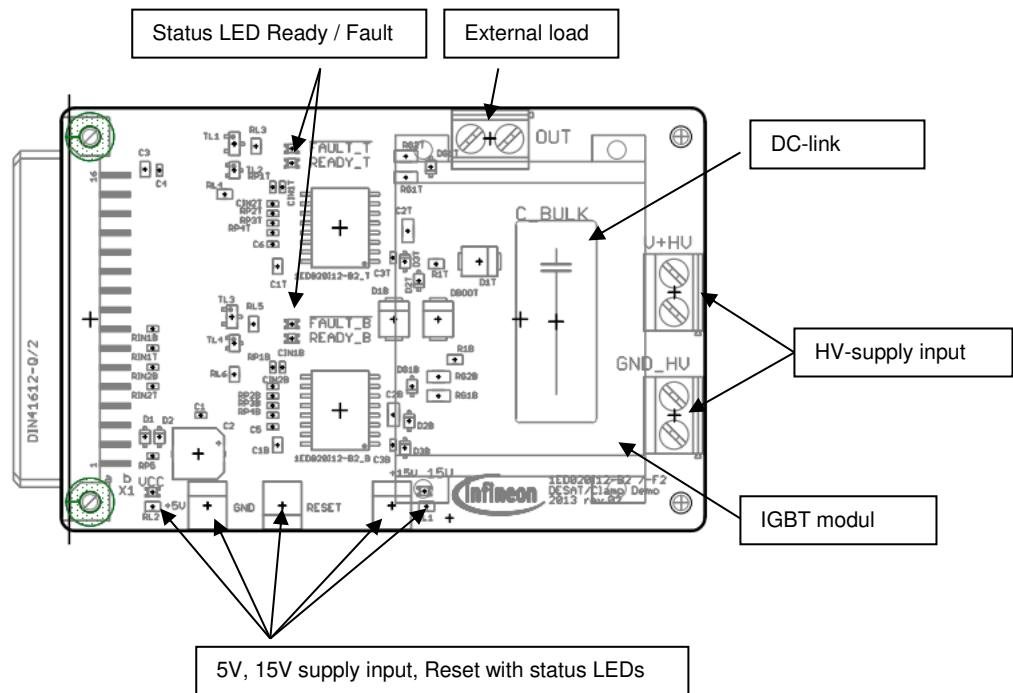

Figure 2-2 overview functionalities on top-side

2.2 Key data

All values are values at an ambient temperature of 25°C.

Table 2-1

Parameter	Description	Typ.	Min.	Max.	Unit
+15V	15V voltage supply	15	13	17.5	V
5V	5V voltage supply	5	4.5	5.5	V
HV	High voltage supply	-	-	600	V
I_{out}	Output current	-	-	25	A
I_{Gmax}	Max. peak gate driver output current	-	-	2	A
R_{Gmin}	Min. gate resistor to limit gate driver output	-	10	-	Ω

* Please make sure that the maximum rated value never get exceeded. Also the performance and quality can not be guaranteed when using the board with all parameters in maximum rated value at the same time.

2.3 Pin assignment

Table 2-2

Connector name	Pin no.	Pin name	Description
RESET	Right terminal	/RST	same as X1-B1
	Left terminal	GND	same as X1-A16
+5V (VCC1)	Left terminal	+5V	positive 5V logic supply
	Right terminal	GND	same as X1-A16
+15V (VCC2)	Right terminal	+15V	positive 15V supply for secondary side
	Left terminal	GND	
X1	A16	GND	reference for 5V supply and input signals
	B1	/RST	input – 0V to reset circuit
	B2	/FLT	output combined /Fault_T, /Fault_B, 0..5V
	B5	IN-T	inverting input top IGBT; internal pull up
	B6	IN-B	inverting input bottom IGBT; internal pull up
	B7	IN+T	non-inverting input top IGBT; 0V off; 5V on
	B8	IN+B	non-inverting input bottom IGBT; 0V off; 5V on
	B16	+5V	positive 5V supply
GND_HV			reference for high voltage supply (Power-GND, internally connected to GND)
V+HV			positive high voltage supply (up to 800V related to GND_HV)
OUT			Output HV half bridge (related to GND_HV)

2.4 IGBT Module EasyPACK 1B FS25R12W1T4_B11

There is an Infineon IGBT EasyPACK 1B module mounted to the evaluation board. For detailed information refer to the Infineon webpage

http://www.infineon.com/dgdl/ds_fs25r12w1t4_b11_2_0_de-en.pdf?folderId=db3a304412b407950112b4095b0601e3&fileId=db3a30432ad629a6012af0f40a895ded

3 Electrical features

3.1 Supply voltages +5V and +15V

The supply voltage for the digital part (+5V VCC1) and for the driver output (+15V VCC2) has to be supplied externally over the dedicated connectors. The evaluation board does not provide an over voltage supply monitoring, therefore the user has to ensure that the voltages are in the correct range. Voltages above the max. values will lead to damages of the IGBT drivers. The availability of the supply voltages is visible over the green status LEDs.

The high-Side gate driver is supplied over a bootstrap diode DBOOT. To ensure that the bootstrap capacitor is charged before the high side IGBT is switched on, the low side IGBT has to be switched on for a dedicated time.

3.2 Under voltage lockout

The +15V supply VCC2 is monitored by the 1ED020I12-B2. In case of an undervoltage of <13V the driver output is switched off. This status is visible over the yellow READY LEDs for top and bottom side. If the LED is on, the +15V supply is >13V

3.3 VCEsat monitoring for short circuit detection

The Infineon gate driver 1ED020I12-B2 provides a short circuit detection by measuring the V_{CEsat} voltage of the IGBT. If a short circuit occurs, the collector current and the saturation voltage increase. If the IGBT is commanded on stated and the V_{CE} reaches 9V a short circuit is detected and the gate driver output is switched off. This status is reported by the /FLT signal and the dedicated FAULT LED is switched on.

Figure 3-1 shows the signals of the bottom side driver and IGBT during a shoot through.

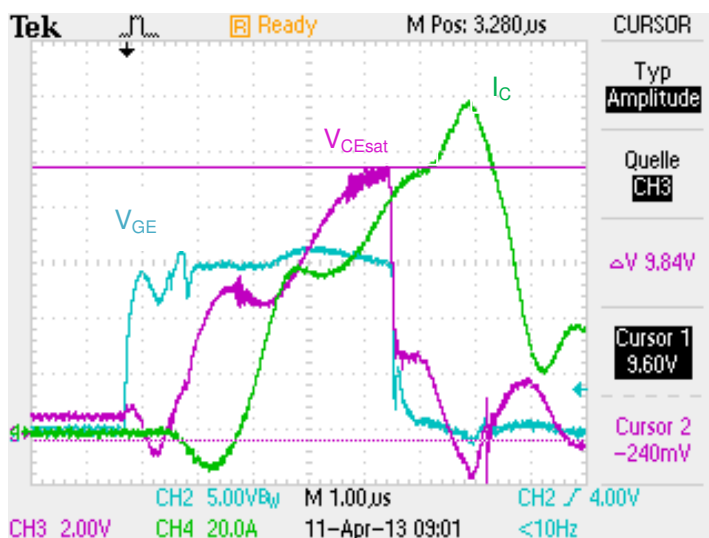

Figure 3-1 the signals of the bottom side driver and IGBT during a shoot through
(I_c curve with 1.2µs delay due to slow current probe)

The FAULT status is latched by the 1ED020I12-B2 and must be resetted by switching the RESET Signal to ground.

3.4 Active Miller clamping

On this evaluation board the Infineon gate driver 1ED020112-B2 is supplied with a unipolar voltage +15V/0V instead of a bipolar supply voltage e.g. +15V/-8V. To avoid a parasitic turn on of the gate by switching on the opposite IGBT, the feature “Active Miller Clamp” of the 1ED020112-B2 is used. During turn-off, the gate voltage is monitored. If the gate voltage goes below 2V related to VEE2, the clamp output is activated and clamps the gate voltage to VEE2 till an on-command for the gate driver output occurs.

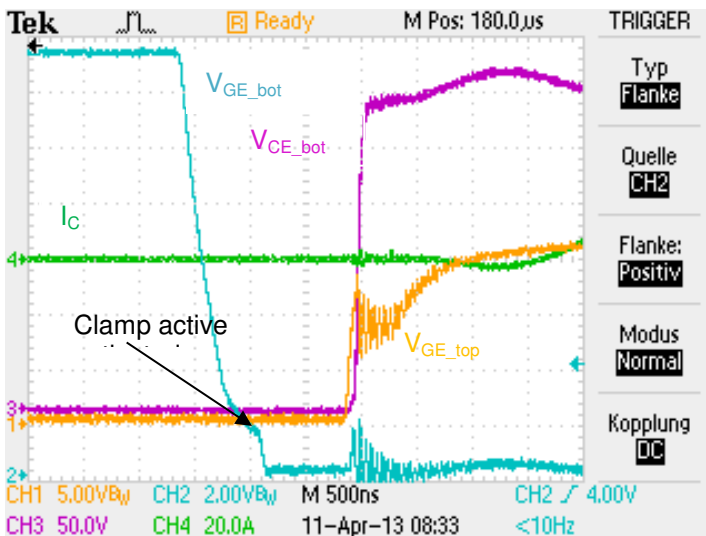

Figure 3-2 the clamping of the bottom side gate at voltages < 2V

3.5 IGBT turn - on / off

The switching characteristic of the IGBTs is defined by the gate resistors RG1B, RG1T, RG2B and RG2T.

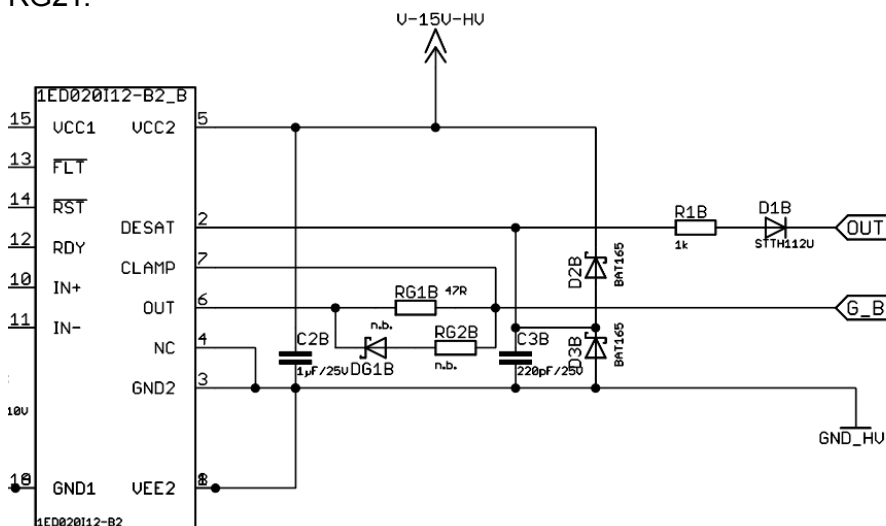

Figure 3-3 bottom side driver output

The gate resistors are adapted to the IGBT module FS25R12W1T4_B11 to get signals with less oscillation as possible by keeping a fast slope at the output. There is the possibility to adapt the switching characteristic to specific applications or to different IGBTs by replacing the values of RG1B

and RG1T. The use of RG2B and RG2T together with DG1B and DG1T makes it possible to change the on-switching and the off-switching slopes of the IGBT independent to each other.

To avoid a shoot through between top- and bottom IGBT, the operator needs ensure sufficient dead time. With this setup the dead time should be $> 1\mu\text{s}$.

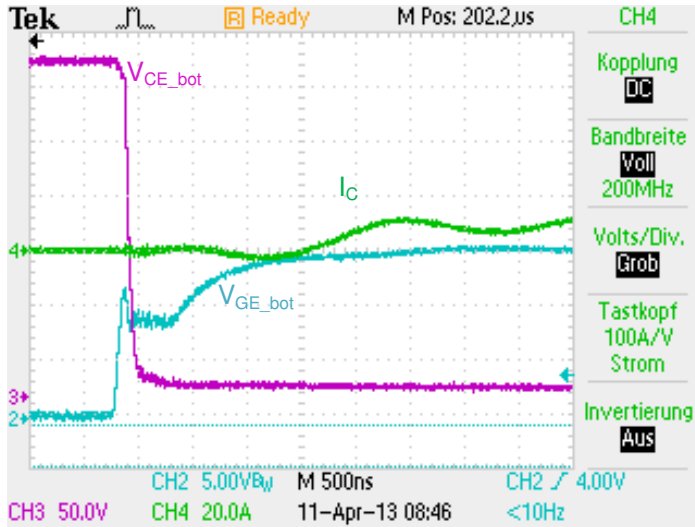

Figure 3-4 turning on bottom IGBT

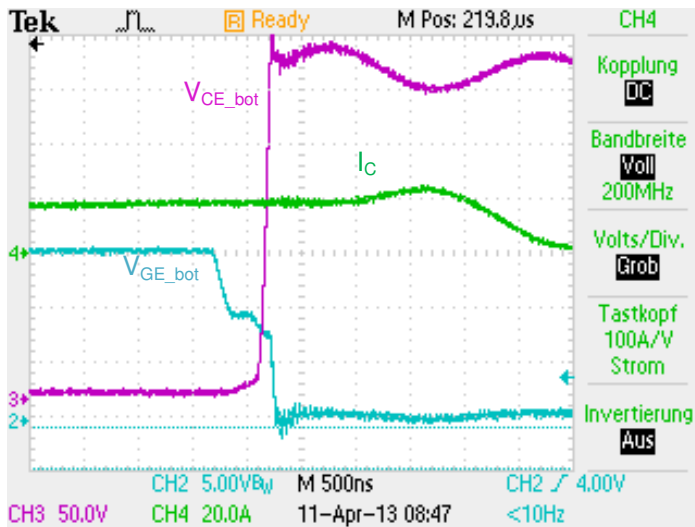

Figure 3-5 turning off bottom IGBT

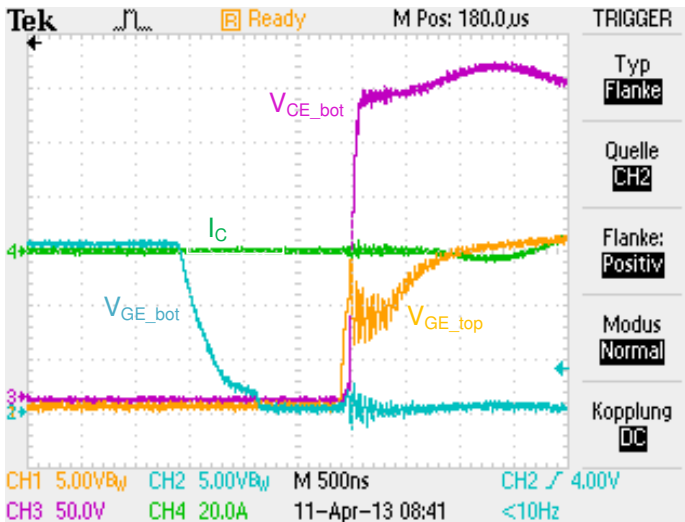

Figure 3-6 turning off bottom IGBT and turning on top IGBT with delay of 1.5μs

3.6 DC-Link capacitor

Due to the available space there is only a small DC-Link capacitor of 220nF available. If a bigger DC-Link capacity is necessary it has to be connected externally to the connectors V+HV and GND_HV.

3.7 Input PWM-Signals

The PWM input pins of the 1ED020112-B2 can be configured in non-inverting input logic or inverting input logic.

- IN+ Non Inverting Driver Input
IN+ control signal for the driver output if IN- is set to low, e.g. the IGBT is on if IN+ = high and IN- = low
- IN- Inverting Driver Input
IN- control signal for the driver output if IN+ is set to high, e.g. the IGBT is on if IN- = low and IN+ = high

The EVAL_1ED020112-B2 is designed in that way, that the non-inverting input is used. There is the possibility to use also the inverting input logic by replace RIN1T, RIN1B and RP1T and RP1B.

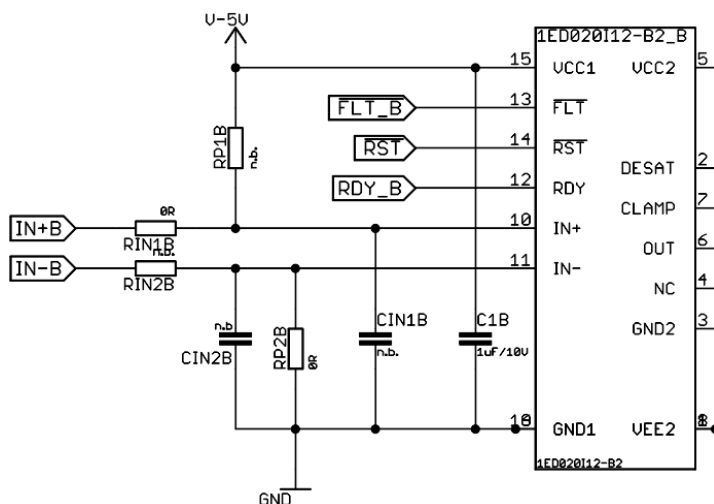

Figure 3-7 bottom side driver input

There is also the possibility to use low pass filters inside the PWM input signals to avoid a undesired switch on an IGBT by disturbances. This feature is not used in this evaluation board, but there is the possibility to test it by changing the resistors RIN1T, RIN1B, RIN2T, RIN2B and the capacitors CIN1T, CIN1B, CIN2T, CIN2B.

4 Schematic and Layout

4.1 Schematic

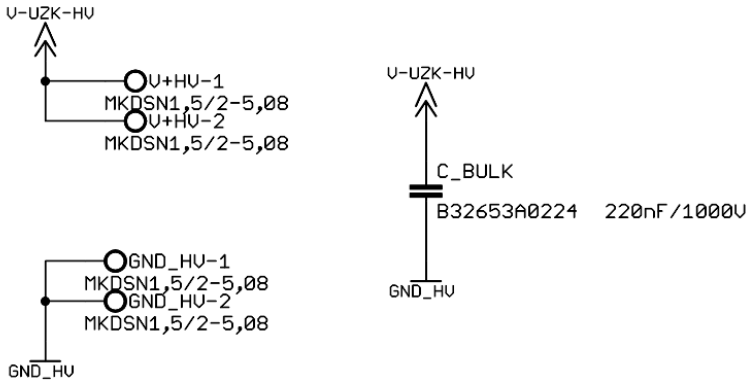

Figure 4-1 HV supply input and DC-Link

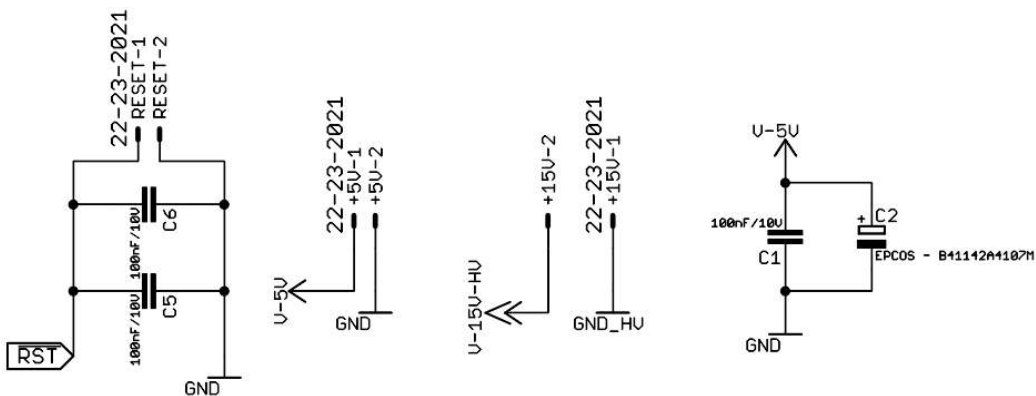

Figure 4-2 LV Supply and Reset Input

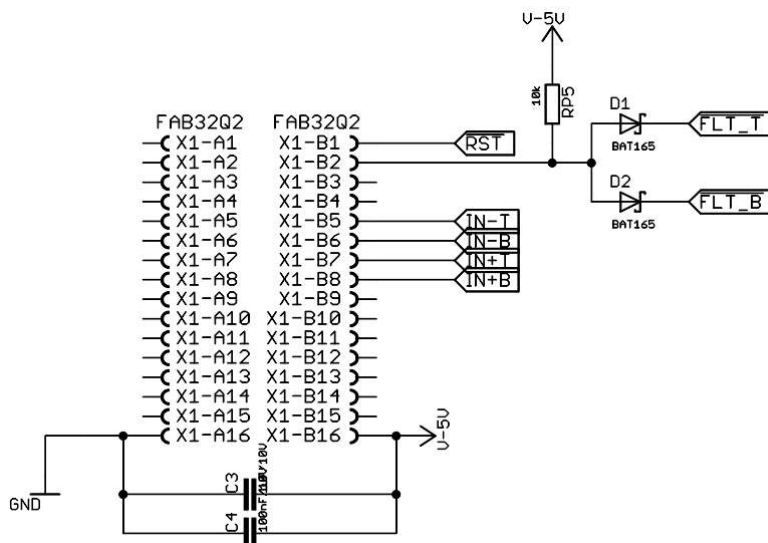

Figure 4-3 connector X1

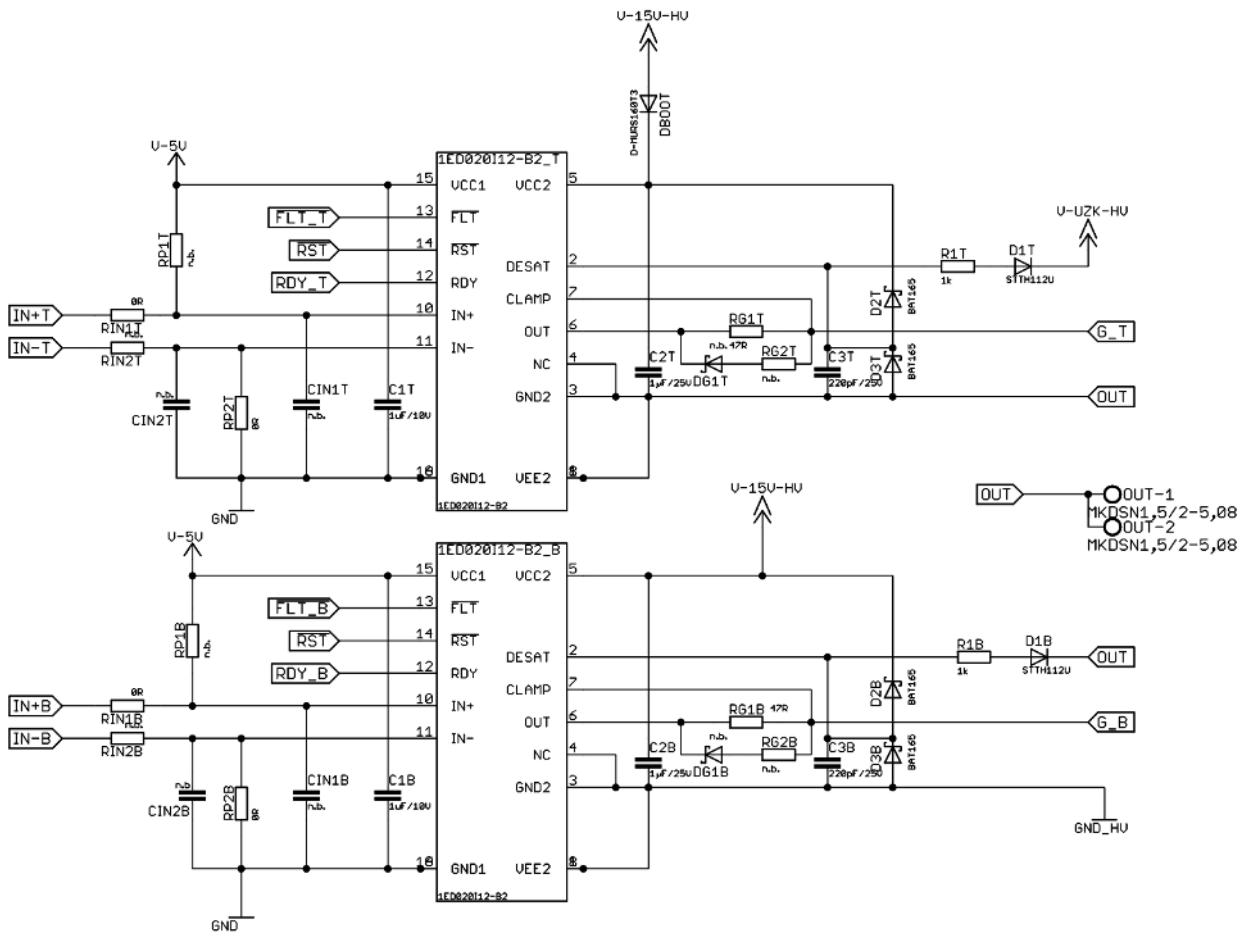

Figure 4-4 Infineon driver 1ED02012-B2 top and bottom

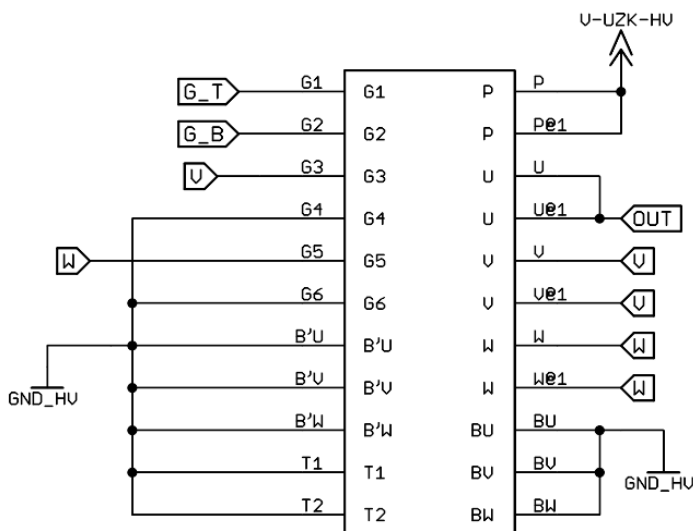

Figure 4-5 IGBT module Infineon FS25R12W1T4_B11

4.2 Layout

4.2.1 Creepage distance

The isolation between input and output is ensured by the coreless transformer of the 1ED020I12-B2 IGBT gate driver. The creepage distance ensured by the layout is 8mm between low- and high voltage supply and 2.4mm inside the high voltage supply area.

4.2.2 Layout top

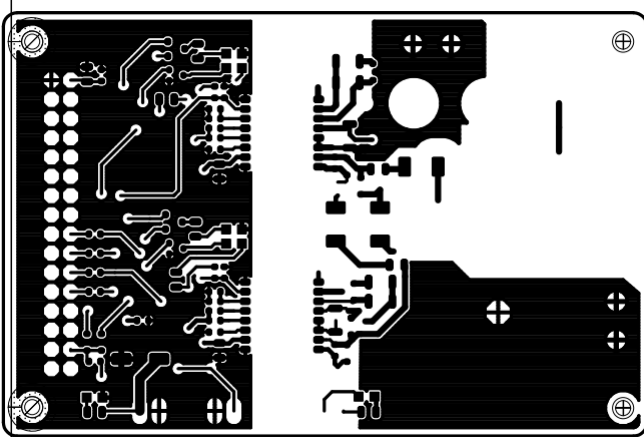

Figure 4-7 Layout top of the EVAL_1ED020I12-B2

4.2.3 Layout bottom

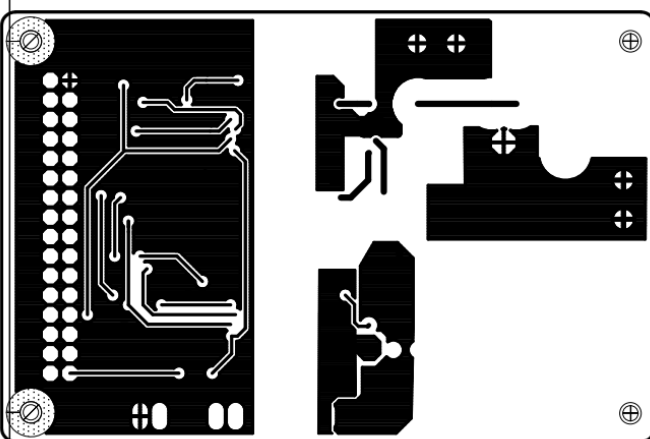

Figure 4-8 Layout bottom of the EVAL_1ED020I12-B2

4.3 Bill of material

Part	Value	Package
C1, C4, C5, C6	100nF/10V X7R	SMD0603
C1B, C1T, C3	1uF/10V X7R	SMD0805
C2	100µF / 16V	6.3 x 6.3 x 7.7mm
C2B, C2T	1µF/25V X7R	SMD1206
C3B, C3T	220pF/25V X7R	SMD0603
C_BULK	220nF/1000V	C22.5B10
D1, D2, D2B, D2T, D3B, D3T	BAT165	SOD323F
D1B, D1T	STTH112U	SMB_DO-214AA
DBOOT	D-MURS160T3	SMB_DO-214AA
R1B, R1T	1k	SMD0805
RG1B, RG1T	47R	SMD1206
RIN1B, RIN1T, RP2B, RP2T	0R	SMD0603
RL1	820R	SMD0805
RL2, RL3, RL4, RL5, RL6	270R	SMD0805
RP3B, RP3T, RP4B, RP4T, RP5	10k	SMD0603
1ED020I12-B2_B, 1ED020I12-B2_T	1ED020I12-B2	PG-DSO-16-15
TL1, TL3	BCR192	SOT23
TL2, TL4	BCR142W	SOT323
U\$3	FS25R12W1T4_B11	FS25R12W1T4_B11
X1	FAB32Q2	FAB32Q2
+5V, +15V, RESET	22-23-2021	22-23-2021
GND_HV, OUT, V+HV	MKDSN1,5/2-5,08	MKDSN1,5/2-5,08
!FAULT_B, !FAULT_T	LED_RT	CHIPLED_0805
15V, VCC	LED_GN	CHIPLED_0805
READY_B, READY_T	LED_GE	CHIPLED_0805

www.infineon.com

Published by Infineon Technologies AG