

Entube SE

Single Ended - Voltage Sensor

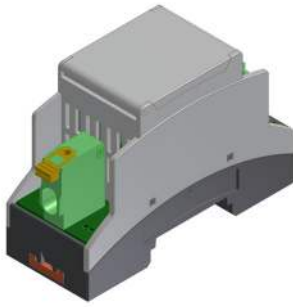

OVERVIEW

The Entube SE series is a family of voltage transducers designed for high quality single ended measurements in a very compact form factor, and without need for power supplies. This series covers the ranges of $\pm 50V$ to $\pm 2000V$ with up to 50kHz bandwidth and up to 0.2% of signal accuracy.

The Entube-de sensor operates as a differential divider RC-network with an anti-aliasing filter on its output. It generates a $\pm 5V$ or $\pm 10V$ scaled down version of the difference between the two input voltages, which can then be processed by a computer based measurement system.

The Entube SE is part of Verivolt's sensing platform, which is aimed at allowing users to laid out multiple distributed sensors with a minimum of cabling required and no power supplies. This platform together with the Entube-de ultra-compact form factor, allows for very high channel densities, while delivering high performance for a low cost.

SPECIFICATION

Entube DE	100V	200V	300V	400V	500V	750V	1000V	1500V	2000V
Bandwidth (-3dB point)	85kHz		50kHz			25kHz			
Integrated sensor noise (Referenced to input)	< 30 μV	< 60 μV	< 100 μV	< 130 μV	< 170 μV	< 220 μV	< 290 μV	< 400 μV	< 500 μV
Gain (Using 10V standard output voltage)	10	20	30	40	50	75	100	150	200
Input Impedance	> 1 M Ω		> 2 M Ω			> 3 M Ω			
Line Output Impedance	50k Ω	25k Ω	33k Ω	25k Ω	20k Ω	20k Ω	15k Ω	10k Ω	7.5k Ω

HARDWARE DESCRIPTION

The Entube SE is a voltage divider designed to measure single phases with reference to ground.

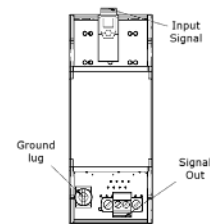

Signal Layout

The input connect to the sensor via a Spring-cage, while the conditioned signals from the sensor come out on a standard screw terminals. The Entube SE can be mounted anywhere between the signal source and the data acquisition system. A female-screw on the low voltage side of the sensor allows for DIN rail mounting, and serves as a safety ground.

A twisted pair should be used to carry the conditioned signals from the sensor. This will keep good resolution beyond the 10th harmonic on a typical 60Hz system.

Electrical	
Accuracy (percentage of reading)	$\pm 0.2\%$ ($\pm 0.05\%$ Typical)
Gain (Using 10V standard output voltage)	
Max total phase shift at 60Hz	< 0.05°
Common mode rejection	$\pm 2000V$
Withstanding differential mode surge voltage	$\pm 1000V$
Mechanical	
Mounting Type	DIN Rail
Connectivity In	Clamp cage
Connectivity Out	Spring cage
Outer Dimensions	1.4" x 1.4" x 4.5"
Weight	198 g (7.0 oz)

Integrated sensor noise (Referenced to input)	
Input-Output non-linearity	< 250 ppm
Output voltage	$\pm 5V$ ($\pm 10V$ optional)
Gain temperature drift	± 50 ppm/°C
Differential input dynamic range	
Common mode rejection	52 dB
Power Supply Voltage	None
Output type	Double-ended signal
Output Offset Voltage	< $\pm 10\mu V$ (on $\pm 10V$ signal)
Environmental	
Operating temperature	- 25 to 70 °C
Storage temperature	- 40 to 80 °C

MERCHANCAL DIMENSIONS

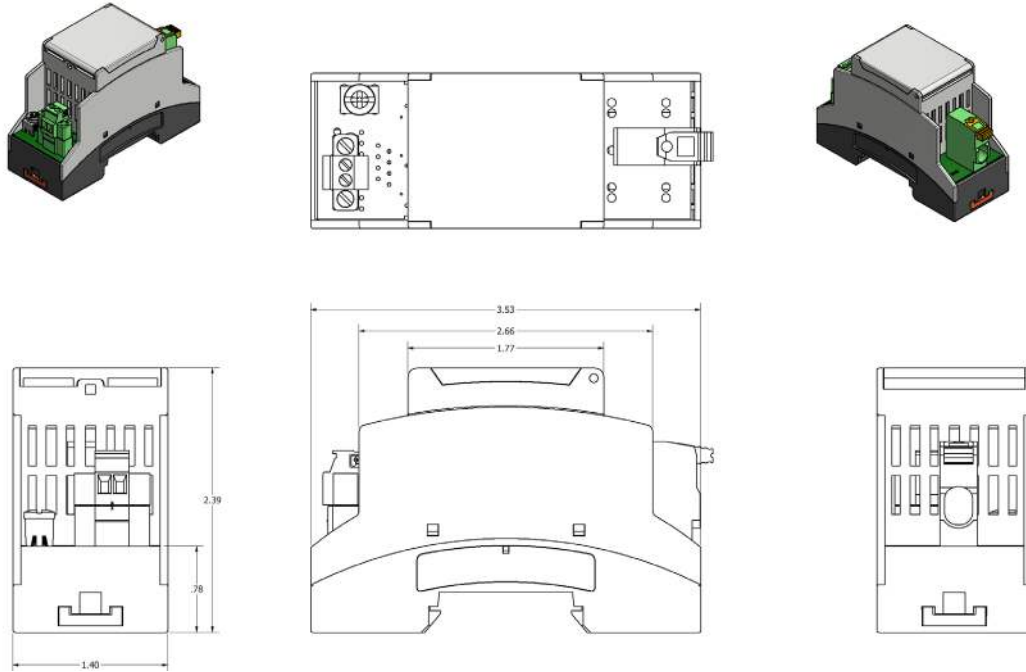

HARDWARE CONFIGURATION

A. Safely connect Data Acquisition ground to ground of sensor.

B. Securely connect one end of a twisted pair to the output terminals, and the other end to the inputs of your breakout board or data acquisition unit

C. Securely connect wire between the source of measurement and an available Entube SE's input clamp cage.

A

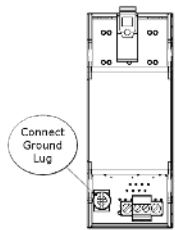

B

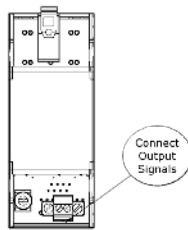

C

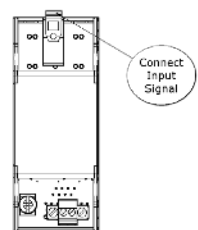

Standards and Certifications

- CE



DANGER

THIS SENSOR IS NOT A SAFETY DEVICE AND IS NOT INTENDED TO BE USED AS A SAFETY DEVICE. This sensor is designed only to detect and read certain data in an electronic manner and perform no use apart from that, specifically no safety-related use. This sensor product does not include self-checking redundant circuitry, and the failure of this sensor product could cause either an energized or de-energized output condition, which could result in death, serious bodily injury, or property damage.