

THIS DRAWING IS UNPUBLISHED. RELEASED FOR PUBLICATION
 © COPYRIGHT BY TYCO ELECTRONICS CORPORATION. ALL RIGHTS RESERVED.

DESIGNED FOR USE WITH RG196/U OR EQUIVALENT CABLE ENTRY DIAMETER MINIMUM	
FERRULE	.101
SLEEVE	.037
DIELECTRIC	.015
CONTACT	.021

LOC	DIST	REVISIONS					
AJ	00	P	LTR	DESCRIPTION	DATE	DWN	APVD
		B		REV PER ECO 07-004710	3/12/2007	DW	KW

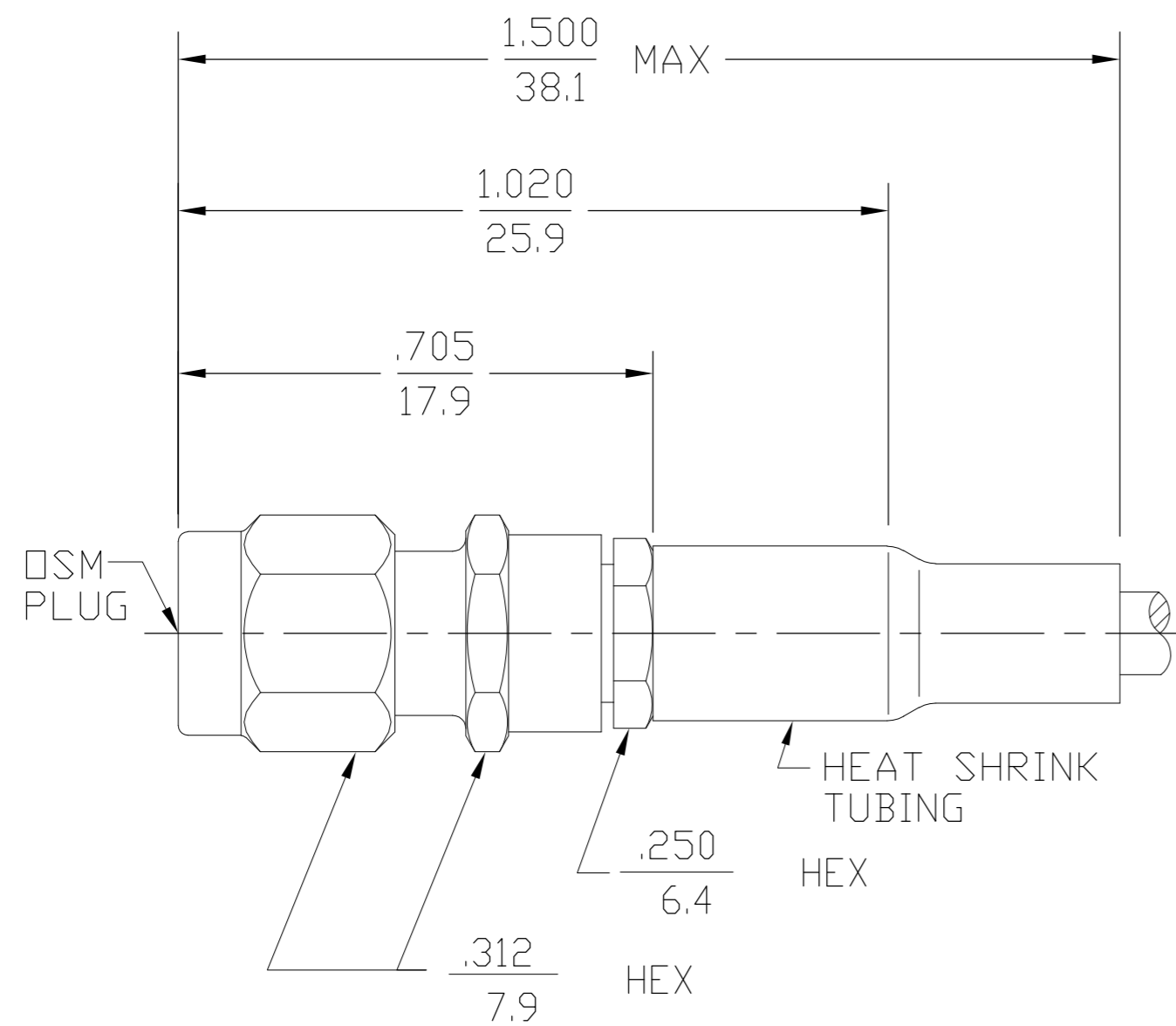

1051687-1
PART NUMBER

COMPONENT	MATERIAL	FINISH
HOUSING COUPLING NUT CLAMP NUT SLEEVE	STAINLESS STEEL PER ASTM-A484 AND ASTM- A582, TYPE 303	PASSIVATE PER ASTM-A380
DIELECTRIC	TFE FLUOROCARBON PER ASTM-D-1457	N/A
DIELECTRIC	NYLON OR ZYTEL #101 PER MIL-M-20693A, TYPE 1	N/A
CENTER CONTACT	BERYLLIUM COPPER PER ASTM B 196, ALLOY C17300, CONDITION H OR BRASS PER ASTM-B-16	GOLD PLATE PER MIL-G-45204
RETAINING RING	BERYLLIUM COPPER PER ASTM B 194, ALLOY C17200, CONDITION H	N/A
GASKET "O" RING	SILICONE RUBBER PER ZZ-R-765	N/A
SHRINK TUBING	HEAT SHRINKABLE POLYOLEFIN COMPOUND MIL-I-23053/4	N/A
FERRULE	COPPER OR BRASS ALLOY ROCKWELL F65 MAXIMUM	GOLD PLATE PER MIL-G-45204

ELECTRICAL	MECHANICAL	ENVIRONMENTAL
Nominal Impedance (Ohms) 50	Interface Dimensions MIL-STD-348A, Fig. 310.1	TEMPERATURE RATING -65°C TO +165°C
Frequency Range (GHz) DC to 12	Recommended Mating Torque 7 to 10 in-lbs	Vibration MIL-STD-202, Method 204, Condition D.
Volt Rating (VRMS MAX) @ Sea Level 170	Mating Characteristics: Insertion (MAX Lbs) N/A	Shock MIL-STD-202, Method 213, Condition I.
VSWR 1.20 +0.025(f)GHz	Withdrawal (MIN Oz) N/A	Thermal Shock MIL-STD-202, Method 107, Condition B, EXCEPT HIGH TEMP +85°C.
Insertion Loss (dB MAX) .06 √F(GHz)	Force to Engage and Disengage (In-Lbs MAX) 2.0	Moisture Resistance MIL-STD-202, Method 106
RF Leakage (dB MIN) -[60-F(GHz)]	Center Contact Captivation Axial (Lbs) 6.0	Corrosion - MIL-STD-202, Method 101, Condition B, 5% salt spray
Corona, 70,000 Ft (VRMS MIN) 125	Cable Retention Axial Force (Lbs MIN) 10	
Dielectric Withstanding Voltage (VRMS MIN) @ Sea Level 500	Torque (In-Oz MIN) N/A	
Contact Resistance (Milliohms MAX) Center Contact 3.0	Weight (Grams) TBD	
Outer Contact 2.0		
Cable to Housing 0.5		
RF High Potential @ Sea Level (VRMS MIN @ 5 MHz) 335		
I.R.(Megohms MIN) 10,000		

THIS DRAWING IS A CONTROLLED DOCUMENT.

DWN	RBG	9/17/76
CHK	RMF	10/4/76
APVD	RMF	10/4/76

tyco Tyco Electronics Corporation
Harrisburg, PA 17105-3608

NAME: OSM STRAIGHT CABLE PLUG CRIMP ATTACHMENT

SIZE: A2 CAGE CODE: 00779 DRAWING NO: 1051687 RESTRICTED TO: -

SCALE: 4:1 SHEET: 1 of 1 REV: B