

THIS DRAWING IS SUPPLIED FOR INFORMATION ONLY. DESIGN FEATURES, SPECIFICATIONS AND PERFORMANCE DATA SHOWN HEREON ARE THE PROPERTY OF THE AMPHENOL CORPORATION. NO RIGHTS OF REPRODUCTION ARE IMPLIED. ALL DIMENSIONS ARE SUBJECT TO NORMAL MANUFACTURING VARIATIONS.

# CUSTOMER DRAWING

REVISIONS				
REV#	REVISION ACTION	REV.BY:	APPR.BY:	DATE
A	INITIAL RELEASE	Fred	JL	03/05/2019

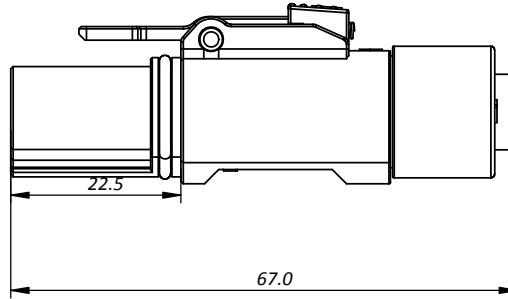
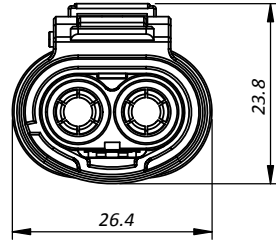

### Standard Part List (Without HVIL) 不带高压互锁

键位 Key	下单料号 P/N	产品名称 Part Name
X	EX-HA004278	PL182X-60 Protection Cap
Y	EX-HA004279	PL182Y-60 Protection Cap
U	EX-HA004280	PL182U-60 Protection Cap

### Standard Part List (With HVIL) 带高压互锁

键位 Key	下单料号 P/N	产品名称 Part Name
X	EX-HA004281	PL182X-61 Protection Cap
Y	EX-HA004282	PL182Y-61 Protection Cap
U	EX-HA004283	PL182U-61 Protection Cap

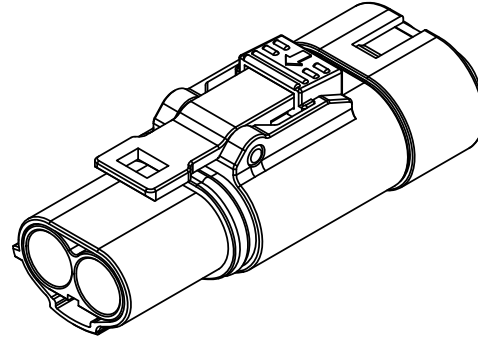

#### 注 Notes:

- 该插头不带端子，仅作防护盖功能。  
This no-contact assembly is only used as protection cap.
- 料号及键位信息见列表。Part number and key information see the table.

	Amphenol Technical Products International Asia.					PART NAME:
	第三角投影 THIRD ANGLE PROJECTION	页面 SHEET	幅面 SIZE	版次 REV.	比例 SCALE	PL182(X/Y/U)-60 Protection Cap
签名 SIGNATURE		日期 DATE		UNLESS OTHERWISE SPECIFIED 1) All dimensions are in metric(mm). 2) Tolerances are as follows: 1.PL DEC ± 1.00 2.PL DEC ± 0.50 3.PL DEC ± 0.20		DWG NO:
制图 DRAWN		审核 CHECKED		批准 APPROVAL		EX-HA004278~83
					CUST PART #	CUST REV.

THIS DRAWING IS SUPPLIED FOR INFORMATION ONLY. DESIGN FEATURES, SPECIFICATIONS AND PERFORMANCE DATA SHOWN HEREON ARE THE PROPERTY OF THE AMPHENOL CORPORATION. NO RIGHTS OF REPRODUCTION ARE IMPLIED. ALL DIMENSIONS ARE SUBJECT TO NORMAL MANUFACTURING VARIATIONS.

# CUSTOMER DRAWING

REVISIONS				
REV#	REVISION ACTION	REV.BY:	APPR.BY:	DATE
A	INITIAL RELEASE	Fred	JL	03/05/2019

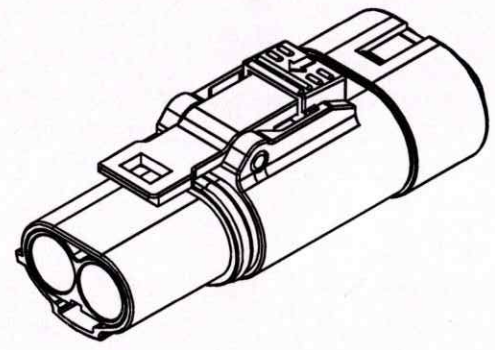
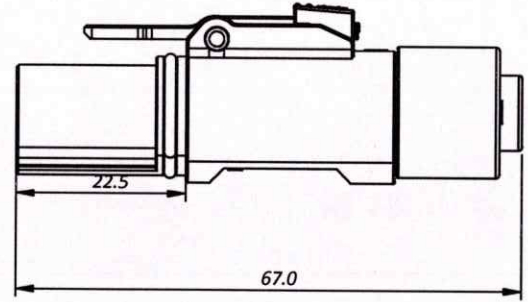
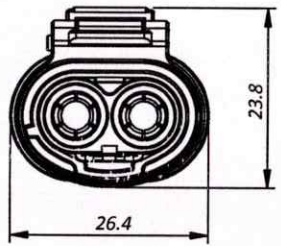

### Standard Part List (Without HVIL)不带高压互锁

键位 Key	下单料号 P/N	产品名称 Part Name
X	EX-HA004278	PL182X-60 Protection Cap
Y	EX-HA004279	PL182Y-60 Protection Cap
U	EX-HA004280	PL182U-60 Protection Cap

### Standard Part List (With HVIL)带高压互锁

键位 Key	下单料号 P/N	产品名称 Part Name
X	EX-HA004281	PL182X-61 Protection Cap
Y	EX-HA004282	PL182Y-61 Protection Cap
U	EX-HA004283	PL182U-61 Protection Cap

注 Notes:  
 1. 该插头不带端子, 仅作防护盖功能。  
 This no-contact assembly is only used as protection cap.  
 2. 料号及键位信息见列表。 Part number and key information see the table.

**Amphenol TPI**  
**2019-03-07**  
**REGISTERED COPY**

	<b>Amphenol Technical Products International Asia.</b>				
	第三角投影 <b>THIRD ANGLE PROJECTION</b>	页面 <b>SHEET</b>	幅面 <b>SIZE</b>	版次 <b>REV.</b>	比例 <b>SCALE</b>
签名 <b>SIGNATURE</b> 制图 <b>DRAWN</b> 审核 <b>CHECKED</b> 批准 <b>APPROVAL</b>	日期 <b>DATE</b> Fred 03/05/2019	1 OF 1 A4 A - UNLESS OTHERWISE SPECIFIED 1) All dimensions are in metric(mm). 2) Tolerances are as follows: 1.PL DEC ± 1.00 2.PL DEC ± 0.50 3.PL DEC ± 0.20			DWG NO: EX-HA004278~83
				Angles ±1°	CUST PART # CUST REV.