



FEATURES

- Full-featured evaluation board for the **AD5930**
- USB cable for PC connection
- Can be powered entirely from USB port
- Various linking options
- PC software for control of the AD5930
- On-board patchwork area

EVALUATION BOARD DESCRIPTION

This data sheet describes the evaluation board for the AD5930 programmable frequency sweep and burst waveform generator. The evaluation board interfaces to the USB port of a PC. It is possible to power the entire board off the USB port. Software is available with the evaluation board, which allows the user to easily program the AD5930.

The AD5930 evaluation board includes a 50 MHz oscillator that provides the MCLK for the AD5930. The user can remove this oscillator, if required, and drive the AD5930 with a different clock oscillator or an external clock source via a BNC connector.

AD5930 DEVICE DESCRIPTION

The AD5930 is a waveform generator that allows a user to generate synthesized analog or digital frequency-stepped waveforms. Because frequency profiles are preprogrammed, continuous write cycles are eliminated, which frees up valuable DSP/ μ controller resources. Waveforms start from a known phase and increment phase continuously allowing phase shifts to be easily determined. The part can be operated with clock frequencies up to 50 MHz.

Complete specifications for the AD5930 are available in the AD5930 data sheet available from Analog Devices, Inc., and should be consulted in conjunction with this data sheet when using the evaluation board.

EVALUATION BOARD BLOCK DIAGRAM

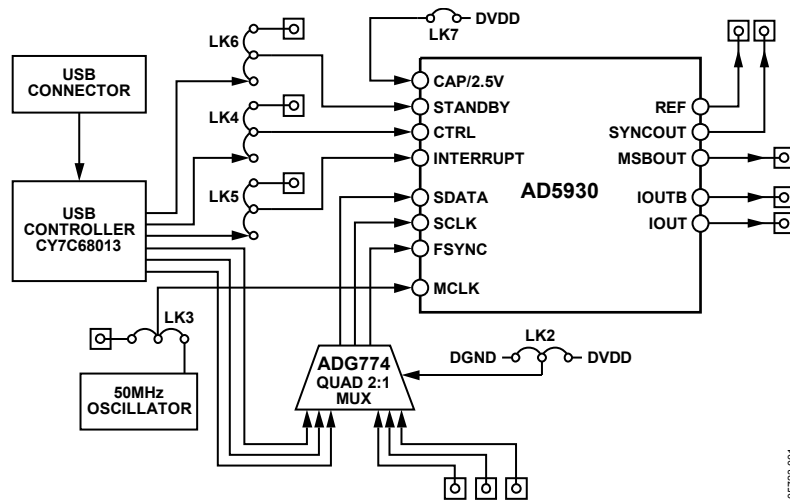

Figure 1.

05723-001

Rev. 0

Information furnished by Analog Devices is believed to be accurate and reliable. However, no responsibility is assumed by Analog Devices for its use, nor for any infringements of patents or other rights of third parties that may result from its use. Specifications subject to change without notice. No license is granted by implication or otherwise under any patent or patent rights of Analog Devices. Trademarks and registered trademarks are the property of their respective owners.

TABLE OF CONTENTS

Features	1	Evaluation Board Software.....	5
Evaluation Board Description.....	1	Installing the Software	5
AD5930 Device Description	1	Using the Software	5
Evaluation Board Block Diagram.....	1	Evaluation Board Schematic and Artwork.....	7
Revision History	2	Ordering Information.....	10
Hardware Description.....	3	Bill of Materials.....	10
Power Supplies	3	Ordering Guide	11
Link Options	4	ESD Caution.....	11

REVISION HISTORY

3/06—Revision 0: Initial Version

HARDWARE DESCRIPTION

POWER SUPPLIES

The AD5930 device has two analog power supply inputs: AVDD (Analog VDD) and AGND (Analog GND). There are also two digital supplies on the part, DVDD (Digital VDD) and DGND (Digital GND). Both of these supplies are independent of each other and can be powered from 2.3 V to 5.5 V.

As well as supplying the digital supply for the AD5930, DVDD is used to provide the supply for the 50 MHz oscillator and the [ADG774](#) quad 2:1 mux.

There are two options available to power the AD5930 evaluation board:

- The USB port of a computer
- A power supply

The default option for powering the board is from the USB port (LK1 and LK8 are in Position B). Alternatively, 2-pin terminal blocks are available to the user for use with an external power supply.

The 5 V from the USB port is regulated to 3.3 V, which provides power for the CY7C68013 USB controller and related USB circuitry. The USB port also provides the GND connections for the board.

When LK1 is in Position B, DVDD is supplied with 3.3 V from the regulator. When LK8 is in Position B, AVDD is powered from DVDD through ferrite bead L1 (600 Ω @ 100 MHz). When LK1 and LK8 are in Position A, the terminal blocks are used to provide power to the board. Note that if you need to operate the part at a different supply than up to 3.3 V, the terminal blocks should be used. In addition, to abide by the maximum ratings of the AD5930, the board should be used as a standalone board if operating at a voltage less than 3 V. Therefore, SCLK, SDATA, FSYNC, CTRL, INTERRUPT, and STANDBY must be externally supplied by the user.

DGND and AGND are connected under the AD5930. Therefore, it is recommended not to connect AGND and DGND elsewhere in the system. AVDD and DVDD are decoupled to the relevant ground plane using 10 μ F and 0.1 μ F ceramic capacitors at their source and again at the AD5930.

EVAL-AD5930EB

LINK OPTIONS

The link options on the evaluation board should be set for the required operating setup before using the board. The functions of these links are described in Table 1.

Table 1. Link Options

Link No.	Function	Position Descriptions	Default
LK1	This link selects the power supply source for the digital circuitry (DVDD).	Position A selects J2 as the digital circuitry power supply source. Position B selects the 3.3 V from the ADP3303 regulator that is powered from the USB port as the digital circuitry power supply source.	Position B
LK2	This link controls whether the serial interface of the AD5930 is being driven from a PC or being used in standalone mode.	Position A connects FSYNC, SCLK, and SDATA pins to the USB controller (controlled from the software). Position B connects FSYNC, SCLK, and SDATA pins to their respective SMBs (J3, J4, and J5).	Position A
LK3	This link selects the MCLK source.	Position A selects the on-board oscillator (50 MHz provided). Position B selects an SMB J13 (labeled MCLK).	Position A
LK4	This link selects whether the CTRL signal is being driven by software or externally through an SMB.	Position A connects the CTRL pin to an SMB J6 (labeled CTRL). Position B connects the CTRL pin to the USB controller for software control.	Position B
LK5	This link selects whether the INTERRUPT signal is being driven by software or externally through an SMB.	Position A connects the INTERRUPT pin to an SMB J7 (labeled INTERRUPT). Position B connects the INTERRUPT pin to the USB controller for software control.	Position B
LK6	This link selects whether the STANDBY signal is being driven by software or externally through an SMB.	Position A connects the STANDBY pin to the STANDBY SMB J8 (labeled STANDBY). Position B connects the STANDBY pin to the USB controller for software control.	Position B
LK7	Insert this link to connect the CAP/2.5 V pin to DVDD if operating DVDD at < 2.5 V.		Removed
LK8	This link selects the power supply source for the analog circuitry (AVDD).	Position A selects J14 as the analog circuitry supply source. Position B connects AVDD to DVDD through a ferrite bead L1 (600 Ω @ 100 MHz) and a 1.6 Ω resistor (R16).	Position B

EVALUATION BOARD SOFTWARE

The AD5930EB evaluation kit is shipped with a CD-ROM that includes self-installing software. The PC is connected to the evaluation board using the supplied cable. The evaluation software should be installed before connecting the evaluation board to the PC's USB port. This ensures that the evaluation board is correctly recognized when connected to the PC.

The software is compatible with Windows® 2000 and Windows XP.

INSTALLING THE SOFTWARE

To install the software:

1. Start the Windows operating system and insert the CD.

The installation software should launch automatically. If it does not, use Windows Explorer to locate the file **setup.exe** on the CD. Double-click this file to start the installation procedure.

2. At the prompt, select a destination directory. By default, this is **C:\Program Files\Analog Devices\AD5930**.

Once the directory is selected, the installation procedure copies the files into the relevant directories on the hard drive. The installation program creates a program group called **Analog Devices** with subgroup **AD5930** in the **Start** menu of the taskbar.

3. Once the installation procedure is complete, power up the AD5930 evaluation board as described in the Hardware Description section. Then, connect it to the USB port of the PC using the supplied cable.
4. Double-click the **AD5930** icon to start the program. The evaluation board is then automatically detected.

USING THE SOFTWARE

To launch the software, click **Start > All Programs > Analog Devices > AD5930 > AD5930 Evaluation Software**. The software for the AD5930 board is presented in wizard format. Note that no download of data to the evaluation board takes place until you click the **Write to Part** command button in the last screen (see Figure 6). This means that it is possible to use the software to help calculate the required write sequence without having the board attached to the computer.

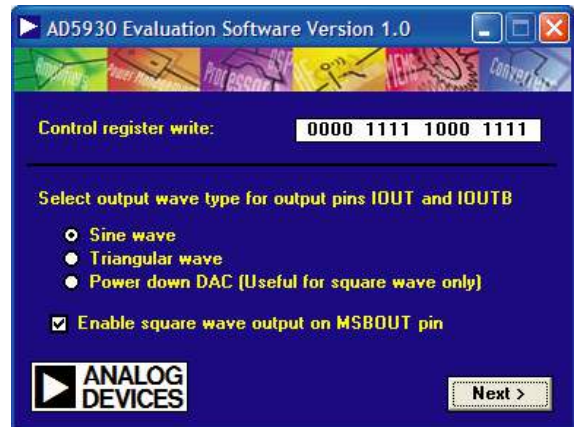

Figure 2. First Window in Wizard

Figure 2 displays the first window in the wizard. The first series of questions relate to the required write to the control register. Follow the wizard prompts by selecting the desired answers and click **Next** to proceed to the next screen. The text box labeled **Control register write** is a read-only text box and cannot be changed. It is intended to show the effect your selections have on the control register write.

Both continuous and burst modes of operation are offered with the evaluation board. In addition, both internal and external options for frequency incrementing are offered. More details on all of these options can be found in the AD5930 data sheet.

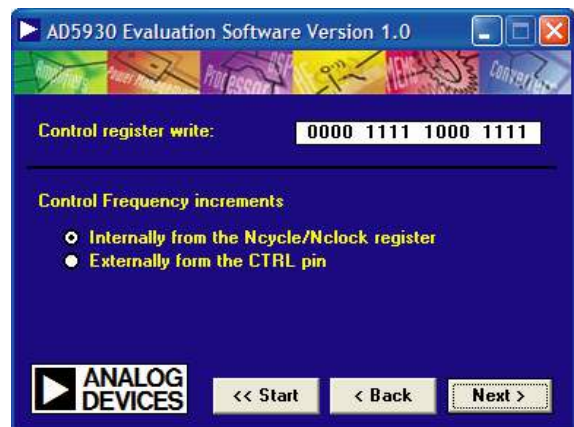

Figure 3. Internal/External Increment Options

After completing the control register write section, you are required to enter the frequency of MCLK. This value is then used to calculate all frequency and time values throughout the software.

EVAL-AD5930EB

The next steps in the wizard require you to enter the values for the numeric registers: the start frequency (F_{START}), frequency increments (Δf), number of increments (N_{INCR}), time interval (T_{INT}), and burst interval (T_{BURST}). Figure 4 shows the first screen of this wizard where F_{START} , Δf , and N_{INCR} are entered. This can be done by entering the hexadecimal value directly or by entering the values in MHz (the software then calculates the corresponding hexadecimal value). Click **Next** to enter T_{INT} and T_{BURST} .

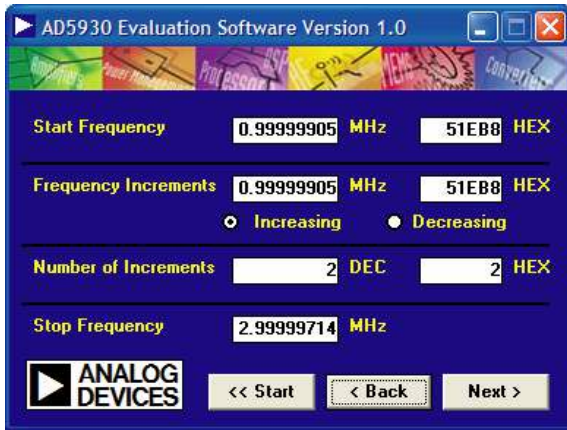

Figure 4. Numeric Registers Values

The SYNC and MSB outputs are also available from the AD5930 evaluation board. The MSB output can be enabled in the first window of the wizard, while both options for the SYNCOP are available, as shown in Figure 5.

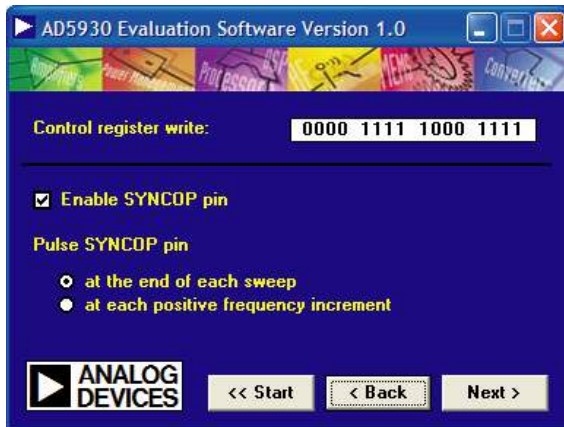

Figure 5. SYNCOP Pin Options

The final screen (Figure 6) displays the required write sequence in hexadecimal, which is calculated based on the responses of the earlier questions. Now click **Write to Part**, which is the first communication with the board. This write programs the AD5930 registers. However, it is necessary to click **Pulse CTRL Pin** in order to start the frequency sweep.

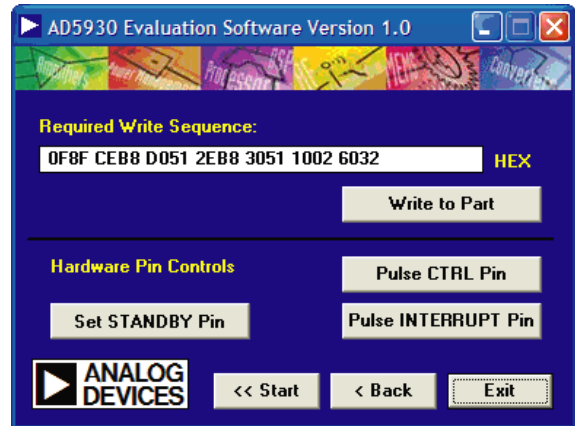

Figure 6. Final Screen

EVALUATION BOARD SCHEMATIC AND ARTWORK

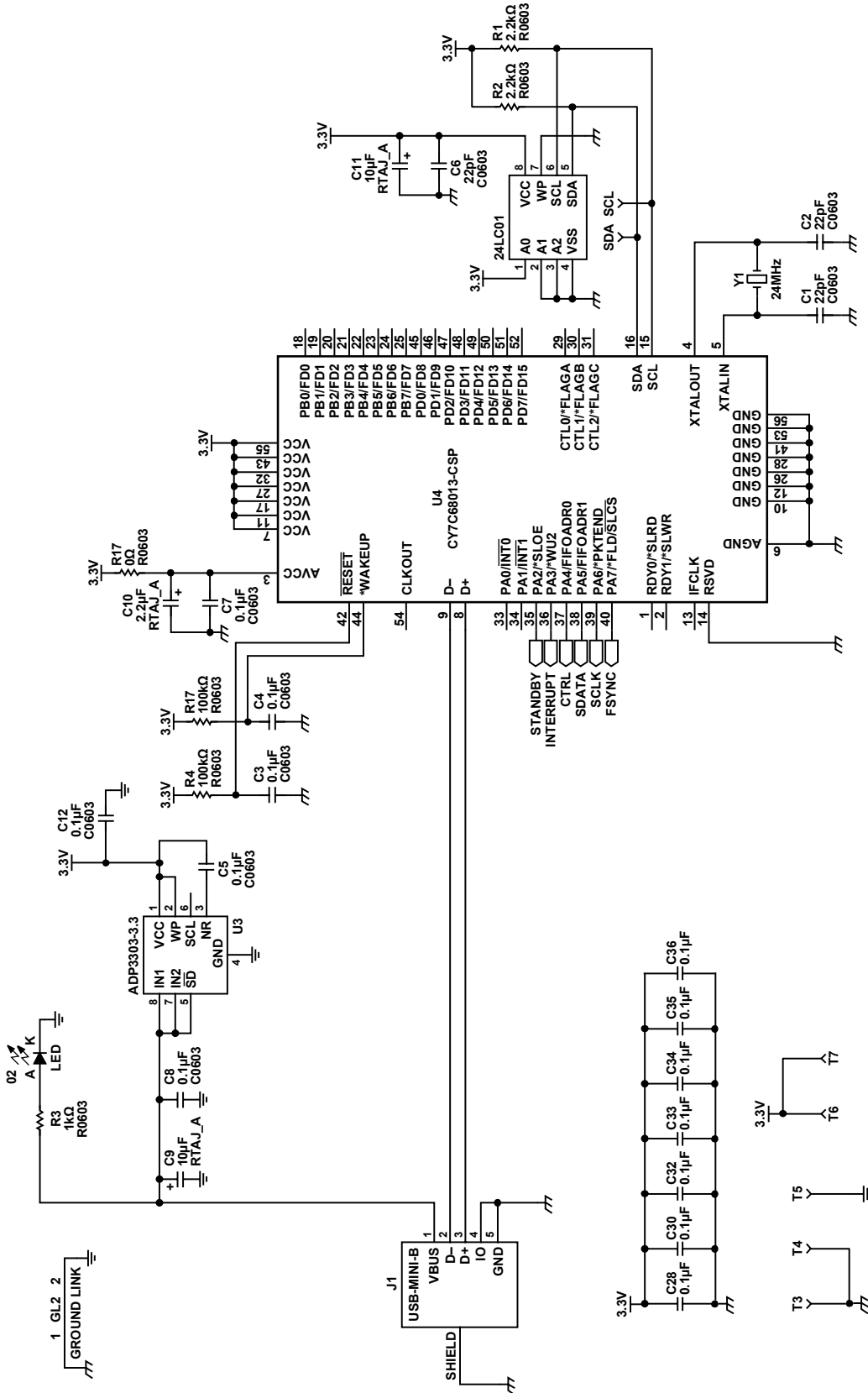
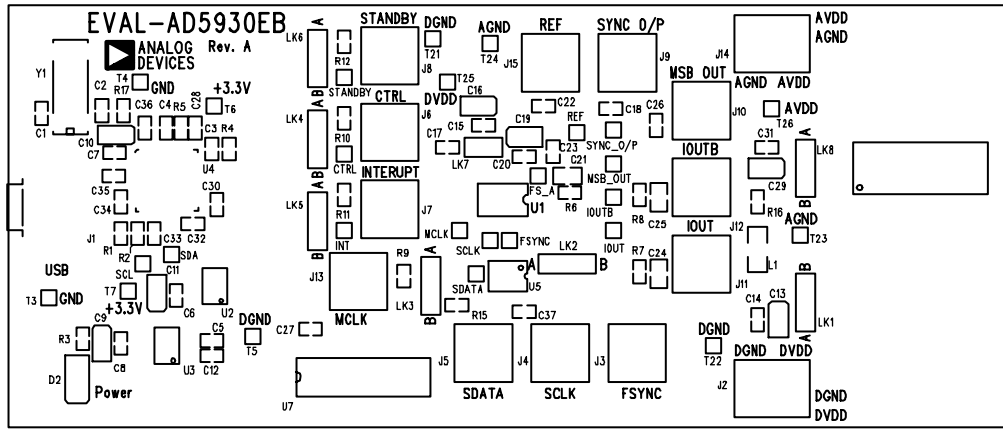

Figure 7. EVAL-AD5930EB Schematic, Page 1 of 2



Eval-AD5930EB Rev. A – Component Side View

Silkscreen

Figure 9. EVAL-AD5930EB Silkscreen Artwork

06723-009

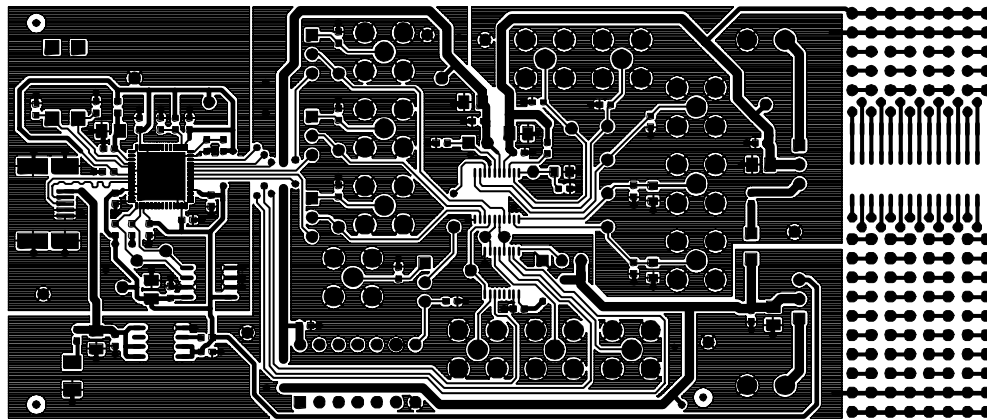

Eval-AD5930EB Rev. A – Component Side View Component Side

Figure 10. EVAL-AD5930EB Component Side Artwork

06723-010

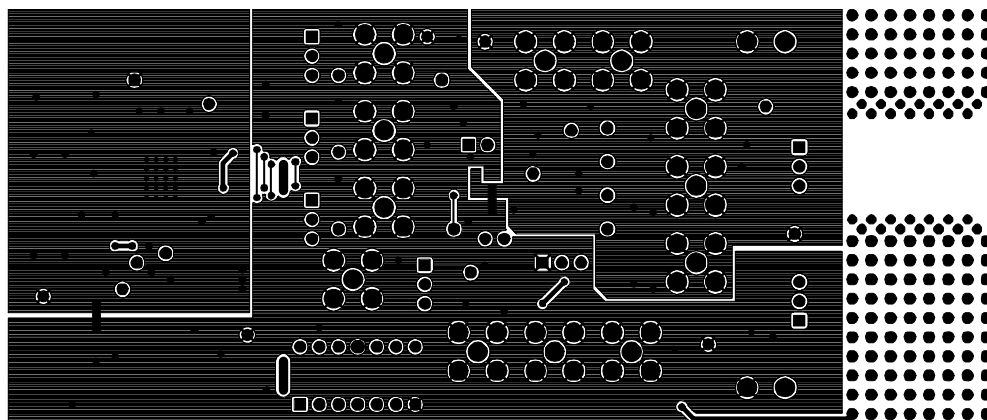

Eval-AD5930EB Rev. A – Component Side View

Solder Side

Figure 11. EVAL-AD5930EB Solder Side Artwork

06723-011

EVAL-AD5930EB

ORDERING INFORMATION

BILL OF MATERIALS

Table 2.

Item	Qty	Reference	Description	Supplier / No.
1	3	C1, C2, C6	22 pF 0603 Ceramic Capacitor	FEC 722-005
2	1	C10	2.2 μ F 0805 Ceramic Capacitor	Digikey 445-1588-1-ND
3	2	C18, C26	0603 Capacitor	Not Inserted
4	3	C21, C24, C25	0805 Capacitor	Not Inserted
5	1	C23	0.01 μ F 0603 Ceramic Capacitor	FEC 722-066
6	21	C3, C4, C5, C7, C8, C12, C14, C15, C17, C20, C22, C27, C28, C30, C31, C32, C33, C34, C35, C36, C37	0.1 μ F 0603 Ceramic Capacitor	FEC 499-675
7	6	C9, C11, C13, C16, C19, C29	10 μ F 0805 Ceramic Capacitor	Digikey 490-1709-1-ND
8	1	D2	Green LED	FEC 515-620
9	1	J1	USB Mini-B Connector (USB-OTG)	FEC 476-8309
10	2	J2, J14	2 Pin Terminal Block (5 mm Pitch)	FEC 151-785
11	12	J3, J4, J5, J6, J7, J8, J9, J10, J11, J12, J13, J15	Subminiature BNC Connector (SMB)	FEC 310-682
12	1	L1	Ferrite Bead (600 Ω @ 100 MHz)	FEC 581-094
13	7	LK1, LK2, LK3, LK4, LK5, LK6, LK8	3-Pin SIL Header (with shorting block)	FEC 512-047 and 150-411
14	1	LK7	2-Pin SIL Header (with shorting block)	FEC 511-705 and 150-411
15	2	R1, R2	2.2 k Ω 0603 Resistor	FEC 911-276
16	3	R10, R11, R12	10 k Ω 0603 Resistor	FEC 911-355
17	1	R15	0603 Resistor	Not Inserted
18	1	R16	1.5 Ω 0603 Resistor	FEC 758-267
19	1	R17	0 Ω Short	FEC 772-227
20	1	R3	1 k Ω 0603 Resistor	FEC 911-239
21	2	R4, R5	100 k Ω 0603 Resistor	FEC 911-471
22	1	R6	6.8 k Ω Resistor	FEC 911-331
23	2	R7, R8	200 Ω Resistor	FEC 357-1312
24	1	R9	50 Ω 0603 Resistor	FEC 422-1825
25	26	T1 to T26	Testpoint	FEC 240-333
26	1	U1	AD5930	AD5930
27	1	U2	IC Serial EEPROM 64 K 2.5 V 8-SOIC	Digikey 24LC64-I/SN-ND
28	1	U3	Precision Voltage Regulator	ADP3303AR-3.3
29	1	U4	CY7C68013-CSP USB Microcontroller	Embassy CY7C68013-56LFC
30	1	U5	Quad SPDT Switch/2:1 mux	ADG774BRQ
31	1	U7	50 MHz CMOS/TTL Crystal (and 14-Pin DIP)	FEC 788-480/97103
32	1	Y1	24 MHz CM3095 SMD Crystal	FEC 569-872

ORDERING GUIDE

Model	Description
EVAL-AD5930EB	Evaluation Board

ESD CAUTION

ESD (electrostatic discharge) sensitive device. Electrostatic charges as high as 4000 V readily accumulate on the human body and test equipment and can discharge without detection. Although this product features proprietary ESD protection circuitry, permanent damage may occur on devices subjected to high energy electrostatic discharges. Therefore, proper ESD precautions are recommended to avoid performance degradation or loss of functionality.



EVAL-AD5930EB

NOTES