

REVISIONS			
REV	DESCRIPTION	DATE	APPROVED
A	INITIAL RELEASE	08/15/06	A.D.M.

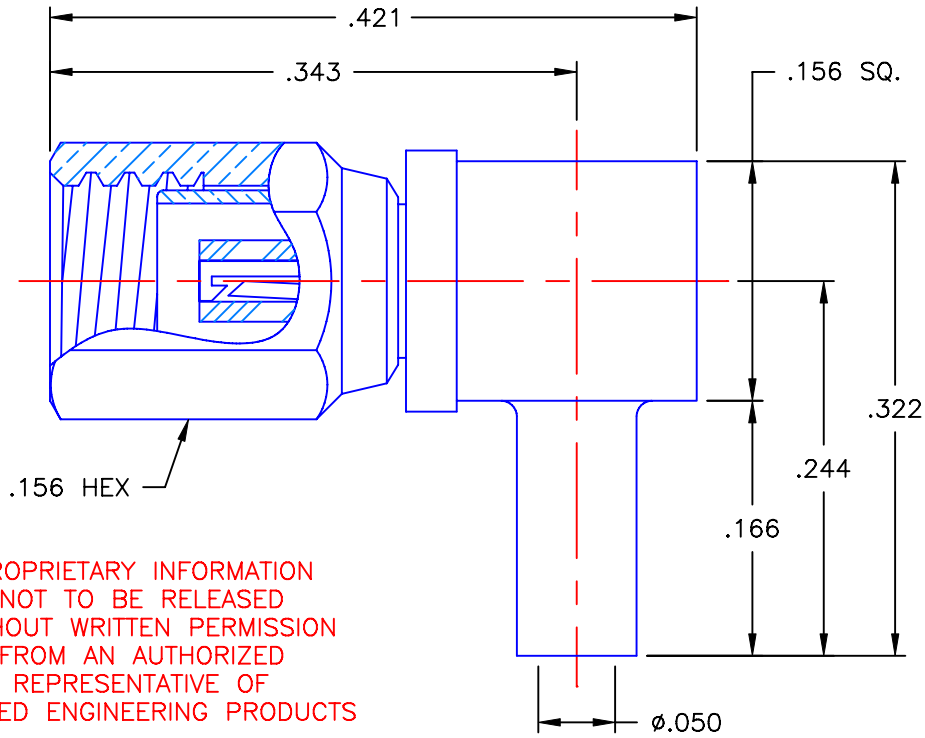

PROPRIETARY INFORMATION
NOT TO BE RELEASED
WITHOUT WRITTEN PERMISSION
FROM AN AUTHORIZED
REPRESENTATIVE OF
APPLIED ENGINEERING PRODUCTS

NOTES:

MATERIALS:

1. DIRECT SOLDER BODY & CAP = BRASS PER ASTM B16, ALLOY C36000, TEMPER H02.
2. INSULATORS = VIRGIN WHITE TEFLON PER ASTM D1710, GRADE 1, TYPE I, CLASS "B".
3. ALL OTHER METAL PARTS = BERYLLIUM COPPER PER ASTM B196, ALLOY C17300, TEMPER TD04.

FINISHES:

1. CONTACT = GOLD PLATE PER MIL-G-45204, TYPE II, CLASS 1, GRADE C, OVER .00010 TO .00020 STRESS FREE SULFAMATE NICKEL PER QQ-N-290.
2. ALL OTHER METAL PARTS = GOLD PLATE PER MIL-G-45204, TYPE II, CLASS 0, GRADE C, OVER .00010 TO .00020 COPPER STRIKE PER MIL-C-14550.

UNLESS OTHERWISE SPECIFIED DIMENSIONS ARE IN INCHES TOLERANCES ON		DWN: A.D.M.	DATE 08/15/06	 APPLIED ENGINEERING PRODUCTS 104 John W. Murphy Dr. New Haven, CT 06513 a RADIALL company
DECIMAL	ANGLE	CHKD: D.N.	DATE 08/15/06	
		APVD: D.J.C.	DATE 08/15/06	
REFERENCE:		MATERIALS & FINISHES: SEE NOTES		SSMC RIGHT ANGLE FEMALE PLUG DIRECT SOLDER TYPE FOR .047 S/R & SIMILAR CABLE
ORIGINATOR: A.D.M. DATE: 08/15/06		SIZE A	FSCM NO. 19505	DWG NO. 7105-1561-011
		SCALE 8:1	THIRD ANGLE PROJECTION	REV A SHEET 1 OF 1

7105-1561-011