

Copying of this document and giving it to others and the use or communication of the contents thereof, are forbidden without express authority. Offenders are liable to the payment of damages. All rights are reserved in the event of the grant of a patent or the registration of the utility model or design.

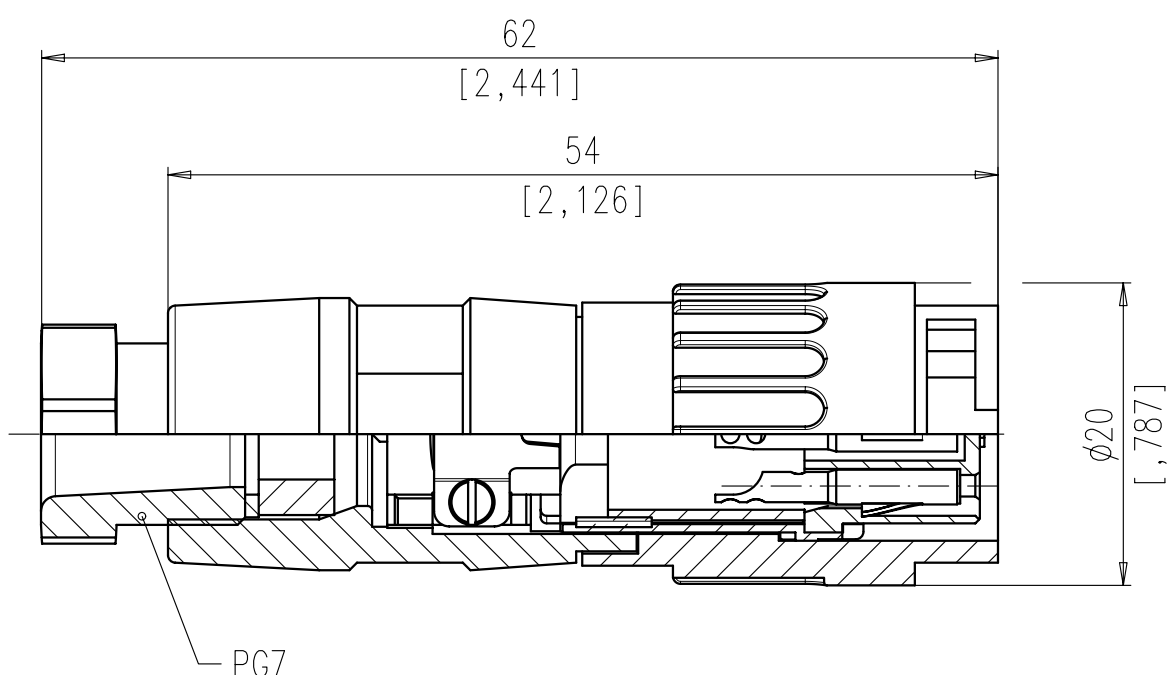

Polzahl number of contacts	Norm standard	3	4	5	5	6	7	7	8	12	14	
D Kontaktanordnung nach DIN contact arrangement acc. to DIN Kontaktanordnung nach IEC contact arrangement acc. to IEC		41524 60130-9	- 60130-9	- -	41524 60130-9	45322 60130-9	- -	45329 60130-9	45326 60130-9	- -	- -	
Bemessungsspannung rated voltage	IEC 60664-1	300V =		100V =	300V =		100V =		150V =			
Bemessungsspannung rated voltage	UL 1977	250V									60V	
Bemessungs-Stoßspannung rated impulse withstand voltage	IEC 60664-1	1500V		1200V	1500V		1200V					
Verschmutzungsgrad pollution degree	IEC 60664-1	1										
Überspannungskategorie installation category	IEC 60664-1	I										
Isolierstoffgruppe insulation group	IEC 60664-1	II, 400 ≤ CTI < 600										
Strombelastbarkeit current rating	IEC 60512-5-2 Test 5b UL 1977	5A / +40°C / +104°F								3A / +40°C / +104°F		
Isolationswiderstand insulation resistance	IEC 60512-3-1 Test 3a	>10 ¹⁰ Ω										
Durchgangswiderstand contact resistance	IEC 60512-2-1 Test 2a	< 5m Ω										
Prüfklasse climatic category	IEC 60068-1	40 / 100 / 56										
Temperaturbereich temperatur range	IEC 60068-1	-40°C ... +100°C -40°F ... +212°F										
B IP-Schutzart IP-degree	IEC 60529	IP 40										
Steck- und Ziehkraft Insertion and withdrawal forces	IEC 60512-13-2 Test 13b	25N 90.oz	30N 110.oz	35N 125.oz	50N 180.oz	55N 200.oz	60N 220.oz	50N 180.oz				
Mechanische Lebensdauer mechanical operation	IEC 60512-9-1 Test 9a	gold/gold ≥ 1000 Steckzyklen/mating cycles										
Werkstoff Gehäuse housing material		Überwurfmutter Messing, Zugentlastung Zink-Druckguß, Oberfläche vernickelt coupling ring brass, strain relief, die cast, nickel plated										
Werkstoff Kontaktträger dielectric material		Thermoplast thermoplastic										
Kontaktoberfläche contact plating		vergoldet * gold plated										
Anschlussstechnik termination technique		löten solder								löten solder		
A Anschlussquerschnitt wire gauge		löten/solder ≤ 0,5 mm ² / 20AWG								≤ 0,25 mm ² / 24 AWG		
Brennbarkeit flammability		UL 94 V0										
Verriegelung locking system		Bajonett bayonet										

	14	T 3648 548
	12	T 3628 548
	8 IEC	T 3528 548
	7 IEC	T 3448 548
	7	T 3438 548
	6	T 3428 548
	5	T 3378 548
	5 IEC	T 3398 548
	4	T 3328 548
	3	T 3278 548
SYMBOL symbol	POLZAHL number of contacts	TYP-NUMMER-AU type-number-AU

Diese Steckverbinder dürfen betriebsmäßig nicht unter Spannung betätigt werden. Metallene Gehäuseteile sind sicher mit dem Schutzleitersystem zu verbinden.
 Do not connect or disconnect under load. Metal housing parts shall be securely incorporated to protected ground.
 * Hinweis für vergoldete Anschlüsse:
 Zur Vermeidung von spröden intermetallischen Verbindungen müssen vergoldete Anschlüsse vor dem eigentlichen Lötvorgang verzinnt werden.

Remark for gold plated contacts:
 In order to avoid brittle inter-metallic connections, gold-plated terminals have to be tin-plated in the solder area.

Gewicht (errechnet)/ Calc WT:	9	Zul. Abw./Tolerances:		Maßstab/Scale	2:1	A3	
Prüfmaß/Testdimension				CUSTOMER DRAWING			
Teileindex Part index number				08	Datum/Date	Name	
				Gez. Drawn	10.07.	Cionvica	Kabeldose gerade PG7
				Gep. Checked			Female cable connector
				Amphenol-Tuchel Electronics GmbH			Blatt/Sheet
01	200700144	10.07.08	CI	M	DB T 3XX8 548	1	1 Bl.
Index	Änderung/Description	Datum/Date	Name	Ers. f./Similar to:			