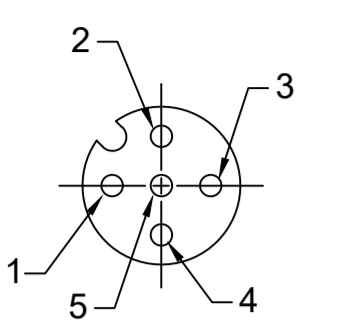
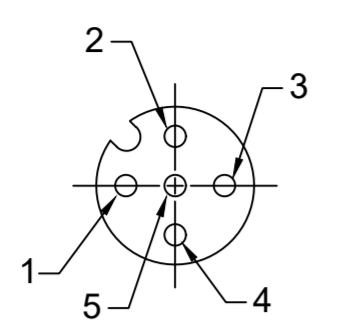
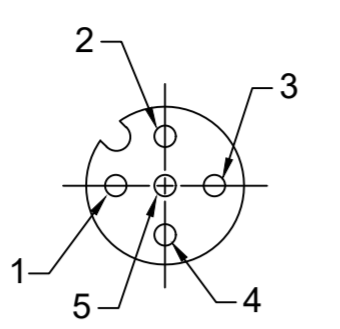

FACE VIEW - FEMALE INSERT

3 POLE	4 POLE	5 POLE
		
1 BROWN 2 NOT USED 3 BLUE 4 BLACK 5 NOT USED	1 BROWN 2 WHITE 3 BLUE 4 BLACK 5 NOT USED	1 BROWN 2 WHITE 3 BLUE 4 BLACK 5 GRAY

NOTES:

- MATERIAL: AS NOTED
- FINISH: AS NOTED
- ELECTRICAL:  
VOLTAGE: 250V  
CURRENT: 4A
- TEMP RATING: -20° TO +105°C (B)
- PROTECTION: IP67 (WHEN MATED)
- COUPLING THREAD: M12X1
- UL RECOGNIZED FILE: E152210  
CSA CERTIFIED FILE: LR6837
- ALL DIMENSIONS ARE FOR REFERENCE  
UNLESS TOLERANCED OR NOTED OTHERWISE

CABLE FLEX CHARACTERISTICS

TORSIONAL FLEX TEST	10 MILLION CYCLES PER MIL-C-13777G
BEND FLEX TEST	10 MILLION CYCLES PER MIL-C-13777G
WELD SLAG RESISTANCE	WOODHEAD STANDARD S-300

ITEM	DESCRIPTION	MATERIAL	FINISH
7	WRAP LABEL	VINYL	BLACK/YELLOW
6	OVERMOLD	TPC	YELLOW
5	O-RING	VITON	RED
4	COUPLING NUT	BRASS	NICKEL PLATED
3	CONTACT SOCKET	COPPER ALLOY	GOLD OVER NICKEL
2	FEMALE INSERT	PUR	BLACK
1	#22 AWG CABLE	TPE JACKET	YELLOW

DOCUMENT STATUS	P1	RELEASE DATE	2021/07/28 23:37:19
-----------------	----	--------------	---------------------

PART NO	ENGINEERING NO.	FINISHED LENGTH	POLES	CABLE DIA.
1200651489	803001K05M020	2M [6FT 7 IN]	3	.20 [5.1]
1200651995	804001K05M250	25M [82FT]	4	.21 [5.3]
1200652460	805001K05M300	30M [98FT 5 IN]	5	.23 [5.8]

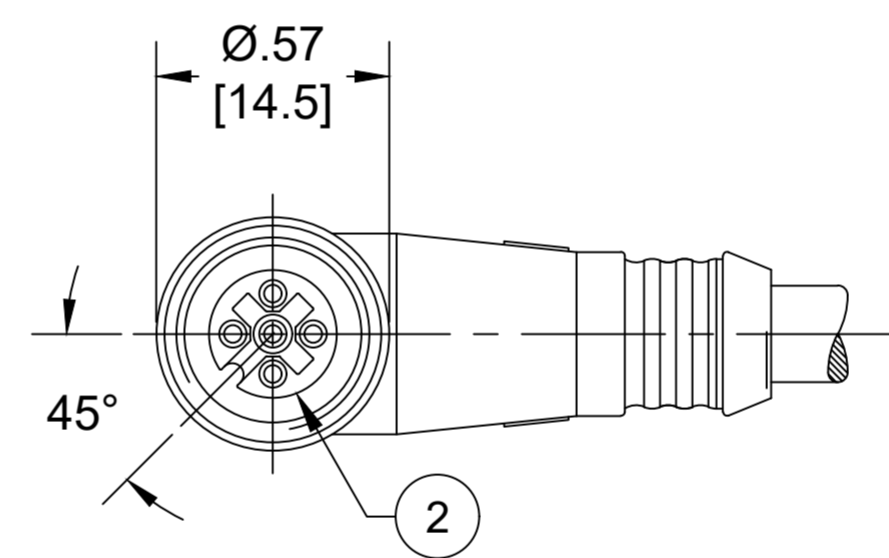
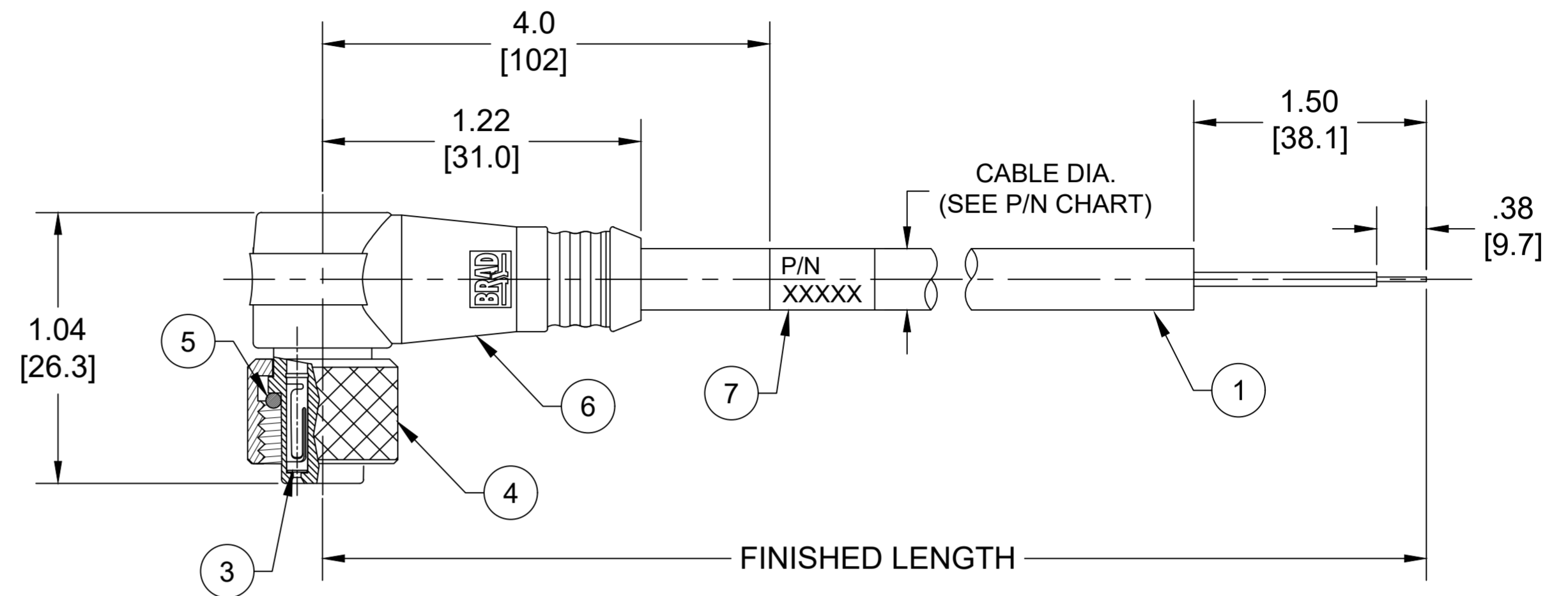

PART NO. MATRIX  
803001K05M010

POLES (3, 4 & 5)  
FINISHED LENGTH  
M005 = 0.5 METER  
M010 = 1 METER  
M100 = 10 METER

CABLE LENGTH TOLERANCES

<.3M [1FT]:	+19mm-0 [+1.75in-0]
.3 - .9M [1 - 3FT]:	+44.5mm-0 [+1.75in-0]
.9 - 1.8M [3 - 6FT]:	+55.6mm-0 [+2.19in-0]
1.8 - 3.7M [6 - 12FT]:	+88.9mm-0 [+3.50in-0]
3.7 - 7.3M [12 - 24FT]:	+165.1mm-0 [+6.50in-0]
7.3-14.6M [24 - 48FT]:	+317.5mm-0 [+12.50in-0]
14.6 - 30.5M [48-100FT]:	+622.3mm-0 [+24.50in-0]
OVER 30M [100FT]:	+2% OF FINISHED LENGTH

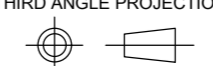
FUNCTIONAL SYMBOLS FA=0 FC=0 FP=0	DIMENSION UNITS INCH/MM	SCALE NTS	CURRENT REV DESC: ITEM #6 WAS TPE. MODIFIED TEMP RATING & PN CHART.	
	GENERAL TOLERANCES (UNLESS SPECIFIED)		EC NO: 671333	2021/04/27
DIVISIONAL SYMBOLS	4 PLACES ±----	±----	DRWN: ABENJAMINLW	2021/07/23
	3 PLACES ±----	±----	CHK'D: RSTONE	2021/07/28
2 PLACES ±----	±----	APPR: BWOODMAN	INITIAL REVISION:	
1 PLACE ±----	±----	DRWN: RSTONE		
0 PLACES ±----	±----	APPR: BWOODMAN	2018/10/25	2018/11/30
ANGULAR TOL ± ---- °		THIRD ANGLE PROJECTION	DRAWING	SERIES
DRAFT WHERE APPLICABLE MUST REMAIN WITHIN DIMENSIONS			C-SIZE	120065

DOCUMENT NUMBER		DOC TYPE/DOC PART/REVISION	
SD-120065-113		PSD	001 B
MATERIAL NUMBER	CUSTOMER	SHEET NUMBER	
SEE CHART	GENERAL MARKET	1 OF 1	