

Evaluating the **ADP8140** 4-Channel, High Current, LED Driver with Adaptable Power Control

FEATURES

Evaluation board voltage range

3 LEDs: 8 V to 30 V

6 LEDs: 15 V to 30 V

Evaluation board current sink range (four adjustable channels)

125 μ A to 350 mA

ADP8140 voltage range: 3.0 V to 30.0 V

ADP8140 current sink range (four adjustable channels)

125 μ A to 500 mA

Analog and PWM dimming inputs and LED current outputs

Feedback output controls external power source for optimal efficiency and safety

EVALUATION KIT CONTENTS

ADP8140CP-EVALZ

ADP8140EB-EVALZ

ADP8140 LED-EVALZ

EQUIPMENT NEEDED

DC power supply

GENERAL DESCRIPTION

The ADP8140CP-EVALZ demonstrates the functionality of the **ADP8140** lead frame chip scale package (LFCSP) current sink light emitting diode (LED) driver.

The evaluation kit includes the ADP8140EB-EVALZ and the ADP8140 LED-EVALZ. The ADP8140EB-EVALZ has an **ADP8140** with a P-channel metal-oxide semiconductor (PMOS) field effect transistor regulation stage to power the LEDs. The ADP8140 LED-EVALZ houses four strings of 6 LEDs per string.

Use the ADP8140CP-EVALZ to evaluate the **ADP8140** device by driving LED strings with a maximum current of 350 mA per string.

Full specifications for the **ADP8140** are available in the **ADP8140** data sheet. Consult the data sheet in conjunction with this user guide when working with the ADP8140CP-EVALZ.

EVALUATION BOARD PHOTOGRAPH

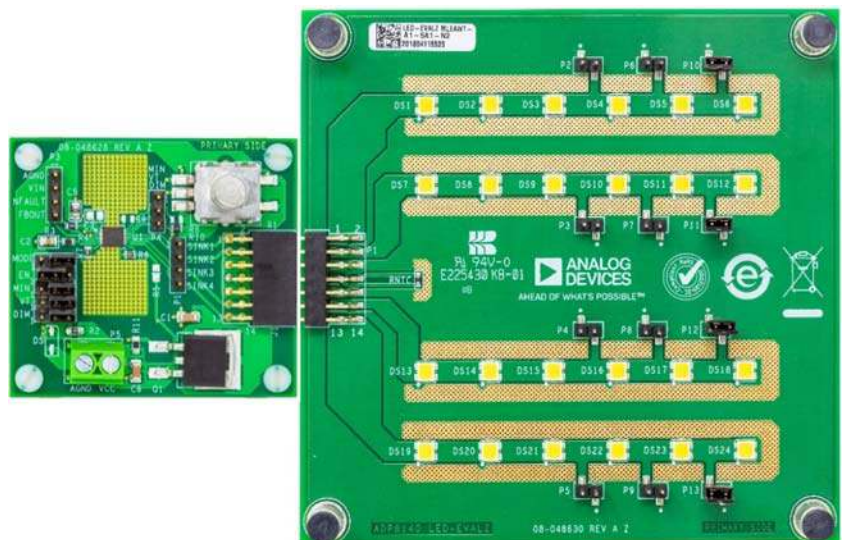

Figure 1.

TABLE OF CONTENTS

Features	1	Using the DIM Pin	5
Evaluation Kit Contents.....	1	Using the VT Pin.....	5
Equipment Needed.....	1	Pulsing the LED Current	6
General Description	1	Using the DIM Pin to Pulse the LED Current	6
Evaluation Board Photograph.....	1	Using the VT Pin to Pulse the LED Current	6
Revision History	2	Evaluation Board Schematics and Artwork.....	7
Evaluation Board Hardware.....	3	Ordering Information.....	10
Evaluation Board Jumper Configurations	3	Bill of Materials.....	10
Evaluation Board Quick Start Procedures	4		
Scaling the LED Current.....	5		

REVISION HISTORY

8/2019—Revision 0: Initial Version

EVALUATION BOARD HARDWARE

EVALUATION BOARD JUMPER CONFIGURATIONS

The evaluation board is configured to light four LED strings from a 24 V supply. To light the LEDs, a PMOS is connected in series to the 24 V supply, which drops the excess voltage. This PMOS is controlled by the [ADP8140](#).

Table 1 outlines the possible configurations of the ADP8140CP-EVALZ (see Figure 2) and describes how to set them. Table 3 lists the components for the ADP8140CP-EVALZ, and Table 4 lists the components for the ADP8140 LED-EVALZ.

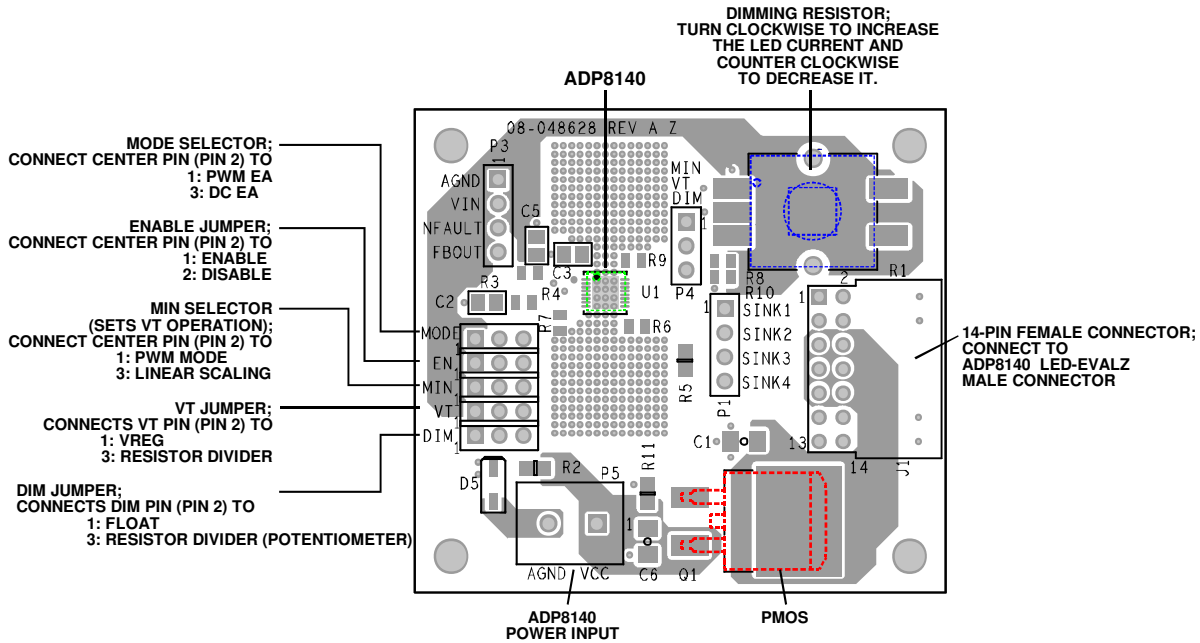

Figure 2. ADP8140EB-EVALZ Features

Table 1. ADP8140CP-EVALZ Function Descriptions

Jumper or Connector	Description
VCC	Power input screw terminal for the ADP8140 and the PMOS regulator.
AGND	Ground screw terminal.
NFAULT	Fault output test point.
FBOUT	Feedback output test point.
MODE	MODE selector, sets the mode of the DIM pin. Connect the center pin to Pin 1 to dim the LEDs based on the DIM duty cycle. Connect the center pin to Pin 3 to dim the LEDs based on the voltage at DIM. To change the mode, turn off the supply and then change the position of the MODE jumper before powering on again.
EN	Enable input. Connect the center pin to Pin 1 to enable the LED driver. Connect the center pin to Pin 3 to disable the LED driver.
MIN (3-Pin)	MIN selector, sets the operation of the VT pin. Connect the center pin to Pin 1 to pulse the LED current based on the pulse-width modulation (PWM) signal on VT. Connect the center pin to Pin 3 to dim the LEDs based on the voltage on VT.
VT (3-Pin)	Voltage threshold jumper. Connect the center pin to Pin 1 to sink the maximum LED current allowed by the ISET pin and the DIM pin. Connect the center pin to Pin 3 to scale the LED current based on the resistance with the negative temperature coefficient (RNTC) resistance.
DIM (3-Pin)	DIM jumper. Connect the center pin to Pin 1 to float this pin for use in PWM mode. Connect the center pin to Pin 3 to scale the LED current based on the wiper voltage of the potentiometer.
SINK1	Current Sink 1 test point.
SINK2	Current Sink 2 test point.
SINK3	Current Sink 3 test point.
SINK4	Current Sink 4 test point.
J1	Double row header to connect ADP8140EB-EVALZ to ADP8140 LED-EVALZ.

EVALUATION BOARD QUICK START PROCEDURES

To set up the ADP8140EB-EVALZ and the ADP8140 LED-EVALZ, use the following steps:

1. Connect the EN jumper to Pin 1, and connect the MODE jumper, MIN jumper, VT jumper, and DIM jumper to Pin 3. Leave the jumpers floating on the ADP8140 LED-EVALZ board (see Figure 3).

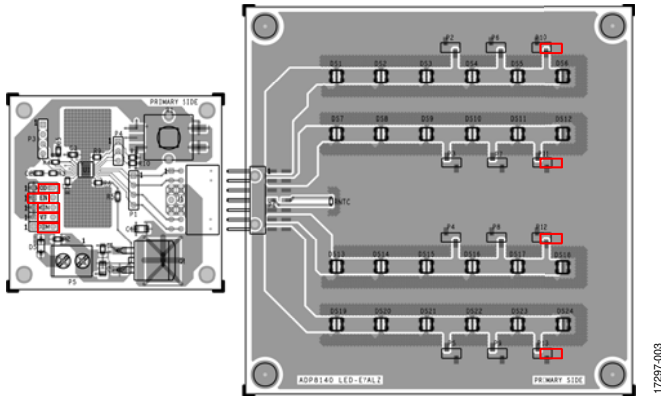

Figure 3. Default Jumper Connections

The jumpers on the ADP8140 LED-EVALZ short the cathode of the diode to the output voltage of the PMOS power stage. When the anode and the cathode of the diode are connected to the output voltage, there is no forward voltage and the diode does not turn on.

2. The ADP8140 LED-EVALZ can be connected face up or face down. To reduce strain to the eyes during testing, connect the LED board with the LEDs facing down.

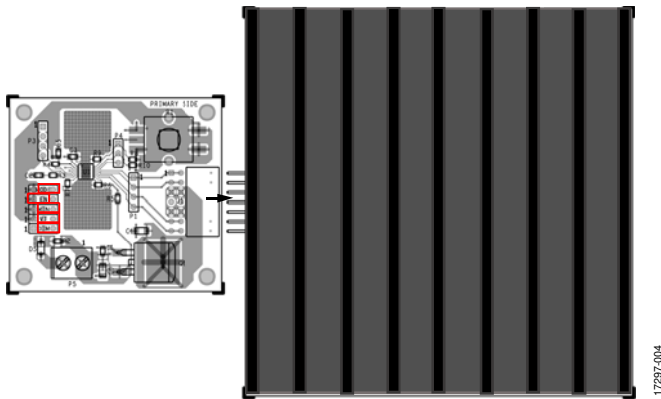

Figure 4. ADP8140EB-EVALZ and ADP8140 LED-EVALZ Connection

3. Connect a 24 V dc supply across VCC and AGND.
4. Turn the potentiometer knob counter clockwise to minimize the LED current.

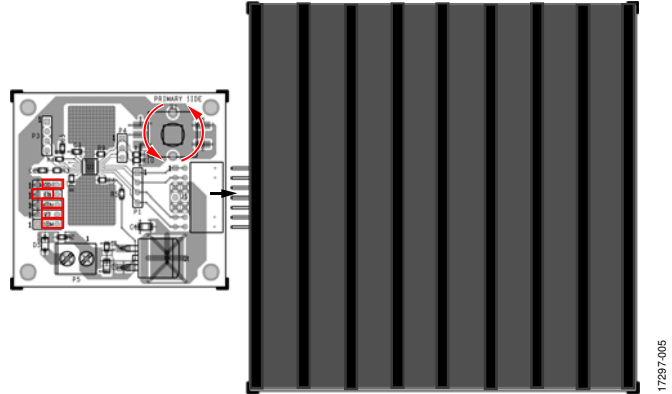

Figure 5. LED Current Reduction

5. Turn on the 24 V supply and turn the potentiometer knob clockwise to increase the LED current.

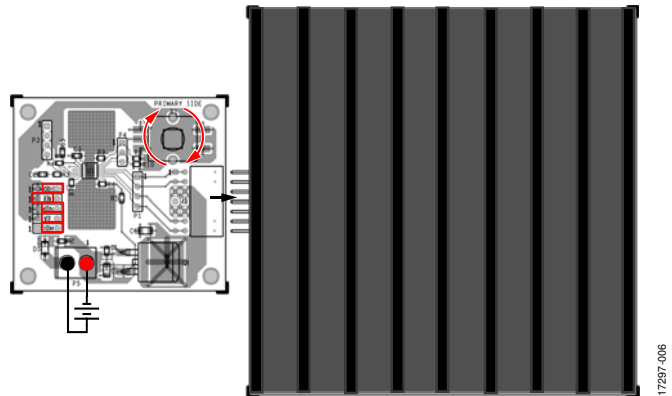

Figure 6. LED Current Increase

SCALING THE LED CURRENT USING THE DIM PIN

The required dimming input depends on the state of the MODE pin during power-up. The ADP8140CP-EVALZ connects the MODE pin to either the REG pin or the GND exposed pad using the MODE selector. The MODE pin state is read during power-up when the voltage at the VIN pin crosses the undervoltage lockout (UVLO) threshold. The mode of operation cannot be changed after power-up.

Table 2. ADP8140CP-EVALZ MODE Pin Configuration

MODE Connection	DIM Pin Mode	Pin Number
REG	PWM signal	1
GND	Analog voltage	3

PWM Duty Cycle Dimming

If the MODE selector three-way pin header ties the center pin to Pin 1, DIM pin requires a PWM input to dim the LEDs.

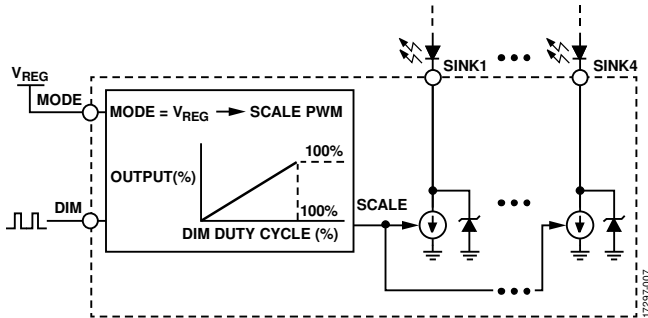

Figure 7. Reduced LED Current Using PWM Signal at DIM Pin

The LED current scales with the duty cycle of the PWM signal. The PWM frequency must be in the 140 Hz to 40 kHz range.

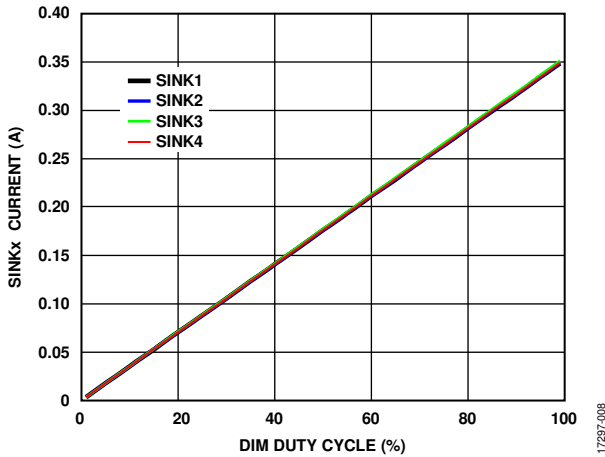

Figure 8. LED Current Scaling Using PWM Signal at DIM Pin

Analog Voltage Dimming

When the MODE selector three-way pin header ties the center pin to Pin 3, DIM requires a dc voltage input to dim the LEDs.

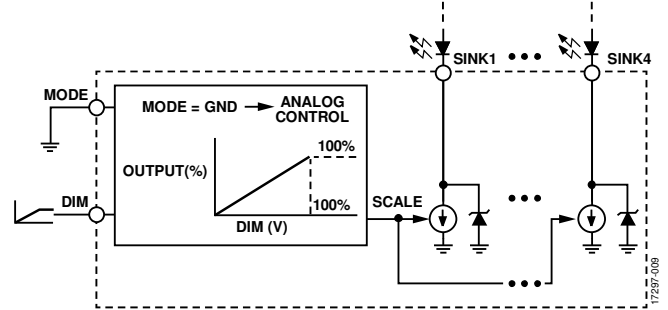

Figure 9. Reduced LED Current Using DC Voltage at DIM Pin

The LED current scales with the ratio of the input voltage up to 2 V. A voltage of more than 2 V does not increase the LED current.

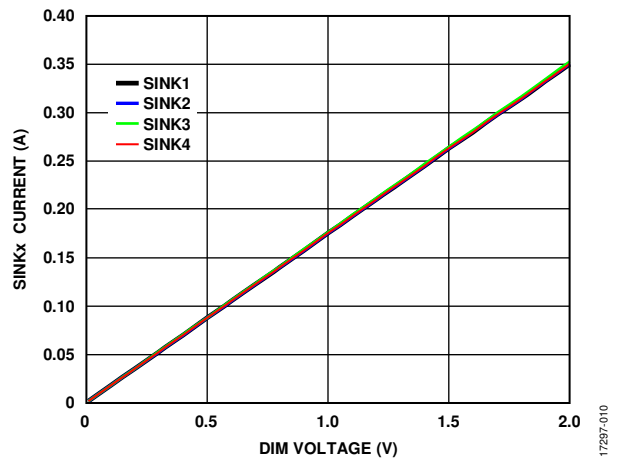

Figure 10. LED Current Scaling Using DC Voltage at DIM Pin

USING THE VT PIN

When the center pin of the MIN selector is connected to Pin 3 upon power up, the VT pin scales the LED current depending on the input voltage level. If the center pin of the VT jumper is connected to Pin 3, the ADP8140EB-EVALZ uses the VT pin to scale the LED current depending on the ADP8140 LED-EVALZ temperature. The LED current scaling is achieved through a resistor divider with a negative temperature coefficient (NTC) bottom resistor, as shown in Figure 11. This scaling causes the divided voltage on the VT pin to lessen when the temperature on the ADP8140 LED-EVALZ rises. The lessening of the divided voltage reduces the LED current.

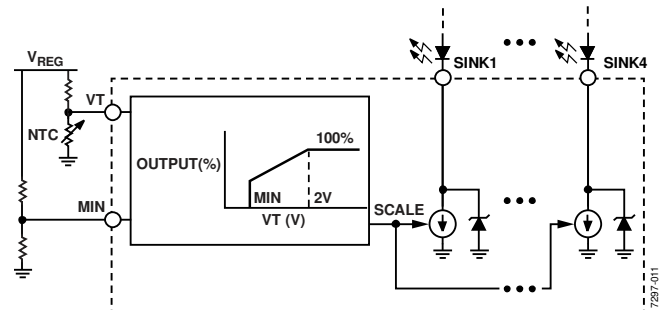

Figure 11. ADP8140 LED-EVALZ Board Current Scaling Using the VT Pin

PULSING THE LED CURRENT

The ADP8140 offers two methods using either the DIM pin or the VT pin to pulse the LED current (see Figure 12 and Figure 13). Use either the DIM pin or the VT pin to achieve similar responses on a simple LED. Note that as the requirements become tighter and more stringent, one of the two methods can be more advantageous than the other, as shown in Figure 14 to Figure 16.

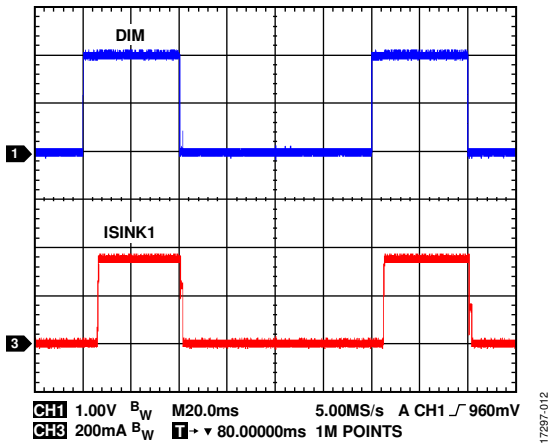

Figure 12. LED Current Pulsing with DIM

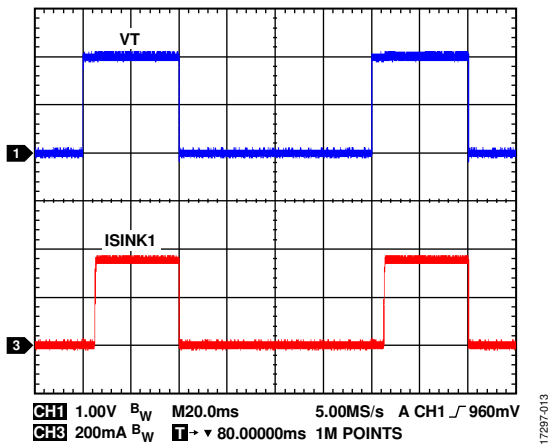

Figure 13. LED Current Pulsing with VT

USING THE DIM PIN TO PULSE THE LED CURRENT

LED pulsing with the DIM pin uses the analog voltage dimming function (see the Analog Voltage Dimming section). Using the DIM pin to pulse the LED current offers flexibility on the high and low current levels of the current pulse, as shown in Figure 14, while using the VT pin to pulse the LED current always results in a low current level of ~250 μ A.

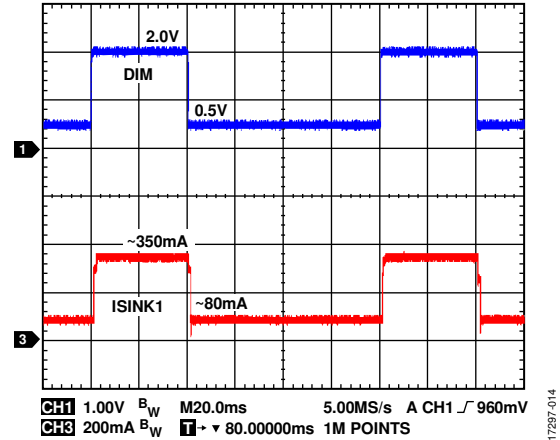

Figure 14. DIM Flexibility During LED Current Pulsing

USING THE VT PIN TO PULSE THE LED CURRENT

When the MIN selector three-way pin header ties the center pin to Pin 1, a logic high voltage on the VT pin allows the ISET pin and the DIM pin to dictate the LED current. A logic low sets the LED current to ~250 μ A. Figure 16 displays the faster response to the input voltage that the VT pin offers compared to the DIM pin.

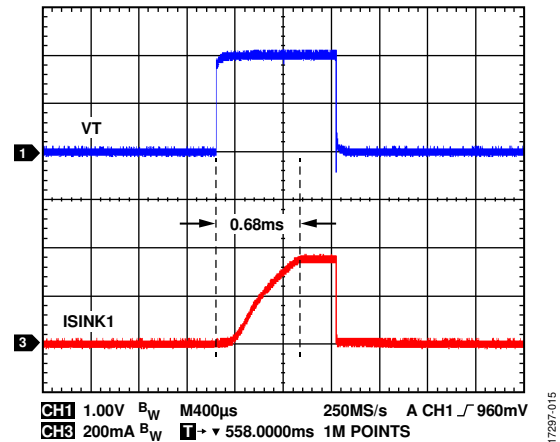

Figure 15. VT Speed During LED Current Pulsing

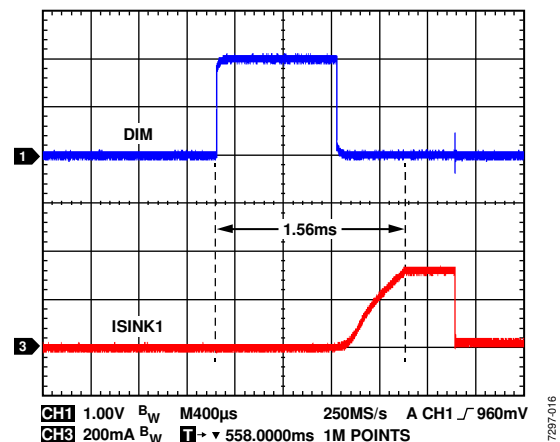

Figure 16. ISINK1 Response in 1 ms Pulse with DIM

EVALUATION BOARD SCHEMATICS AND ARTWORK

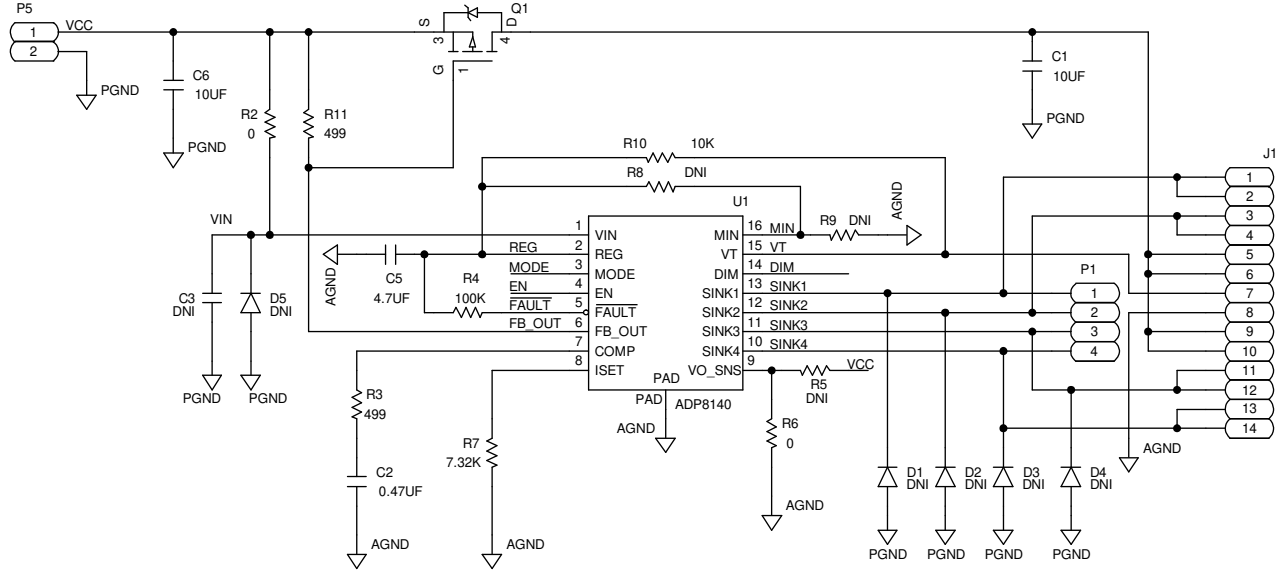

Figure 17. ADP8140EB-EVALZ Schematic

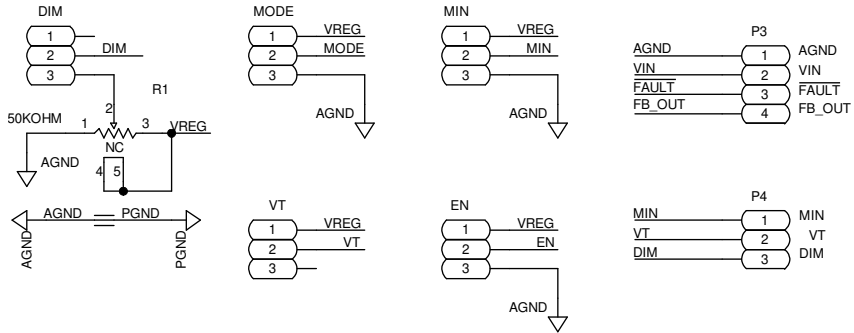

Figure 18. ADP8140EB-EVALZ Schematic Connectors and Peripherals

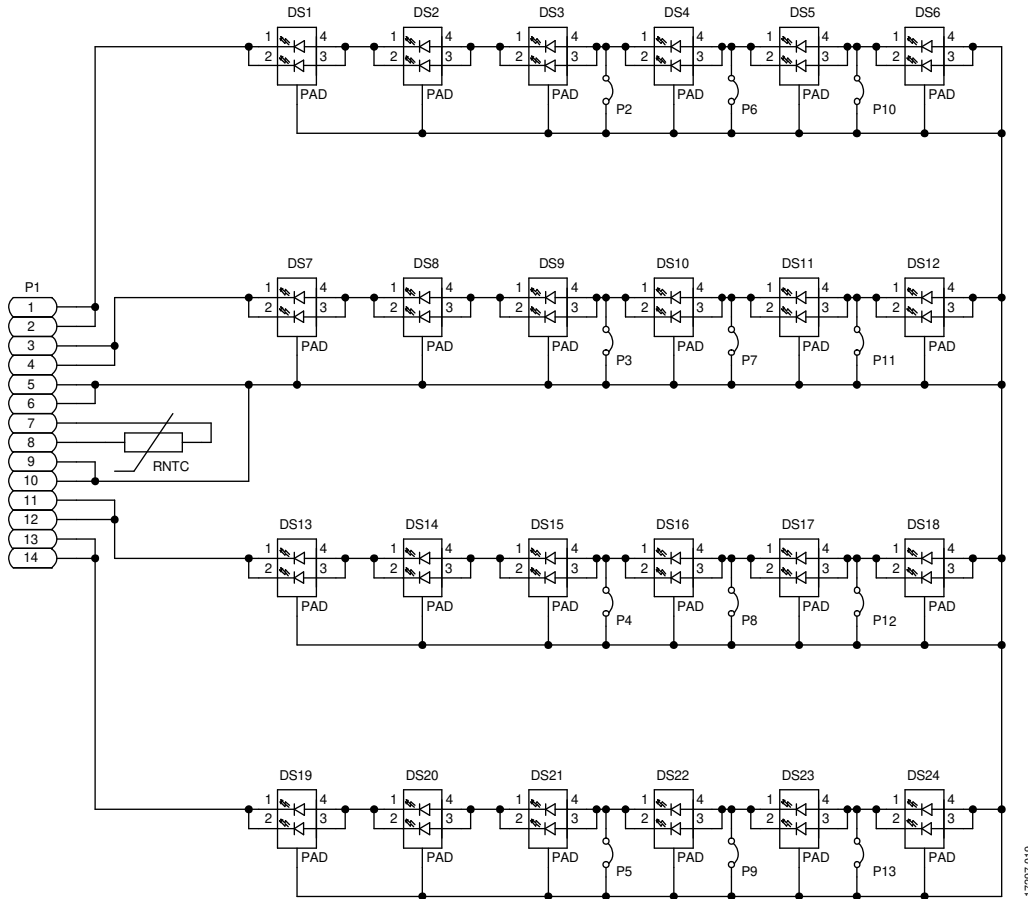

Figure 19. ADP8140 LED-EVALZ Schematic Connectors and Peripherals

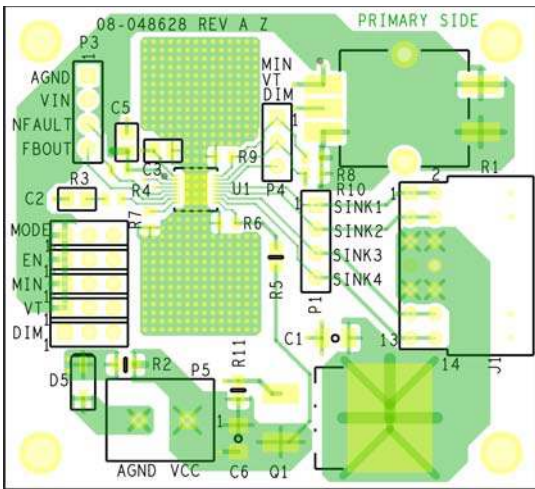

Figure 20. ADP8140EB-EVALZ Top Layer

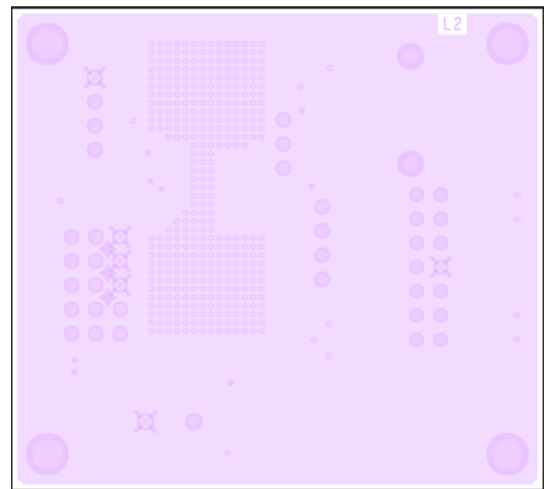

Figure 21. ADP8140EB-EVALZ Second Layer

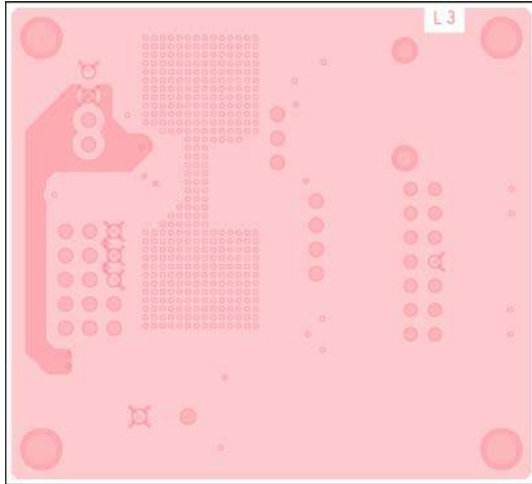

Figure 22. ADP8140EB-EVALZ Third Layer

17297-022

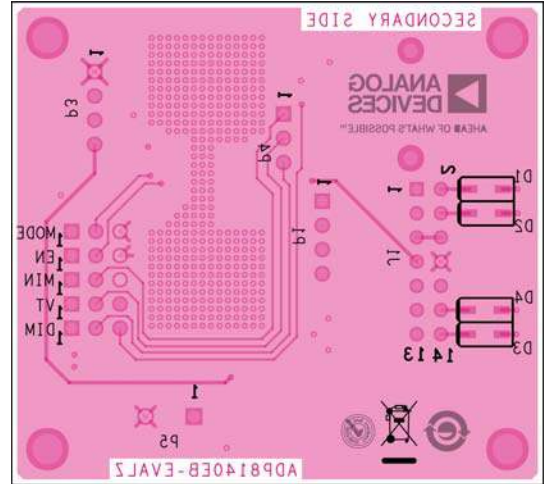

Figure 23. ADP8140EB-EVALZ Bottom Layer

17297-023

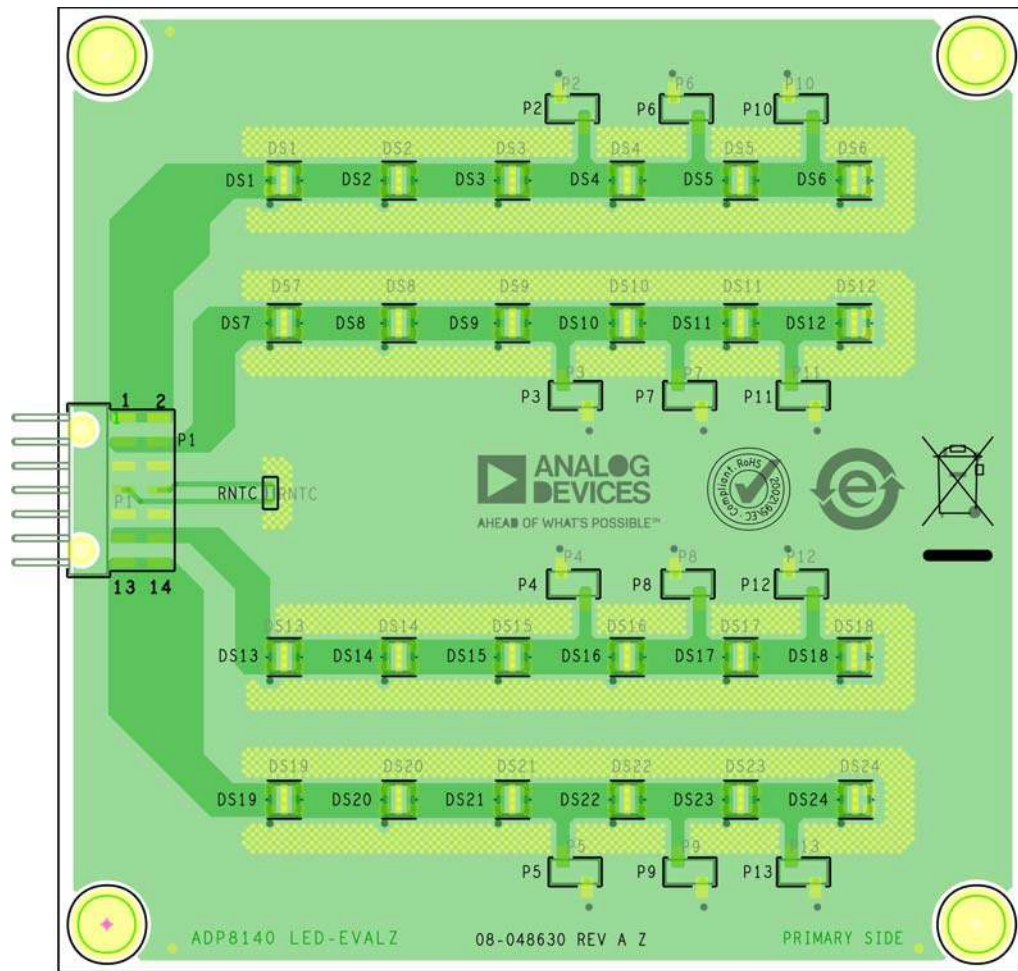

Figure 24. ADP8140 LED-EVALZ Top Layer

17297-024

ORDERING INFORMATION

BILL OF MATERIALS

Table 3. ADP8140EB-EVALZ Components

Component	Description	Part Number	Manufacturer
U1	4-channel, high current, LED driver	ADP8140ACPZ-2-R7	Analog Devices, Inc.
C1, C6	10 μ F ceramic capacitors, X5R	C3216X5R1H106K160AB	TDK Technologies
C2	0.47 μ F ceramic capacitor, X7R, 0805, 25 V	C0805C474J3RACAUTO	KEMET
C5	4.7 μ F ceramic capacitor, X7R, 0805, 16 V	C0805X475J4RACAUTO	KEMET
DIM, EN, MIN, MODE, P4, VT	2.54 mm pitch, 3-pin, single row, straight, male pin header connectors	PBC03SAAN	Sullins Connector Solutions
J1	2.54 mm pitch, 14-pin, double row, right angle, female pin header connector	PPPC072LJBN-RC	Sullins Connector Solutions
P1, P3	2.54 mm pitch, 4-pin, single row, straight, male pin header connectors	PBC04SAAN	Sullins Connector Solutions
P5	5.08 mm pitch terminal block	EDZ250/2	On-Shore Technology
Q1	PMOS	IRF9530NSTRLPBF	Infineon Technologies
R1	50 k Ω linear potentiometer	PRS115-N20K-503B1	Bourns Inc.
R10	10 k Ω resistor, 1%, 0805, 1/2W	CRCW080510K0FKEAHP	Vishay Dale
R3, R11	499 Ω resistors, 0.1%, 0805, 1/8W	ERA-6AEB4990V	Panasonic
R2, R6	0 Ω resistor, 0805, 1/8W	ERJ-6GEY0R00V	Panasonic
R4	100 k Ω resistor, 1%, 0805, 1/2W	CRCW0805100KFAHP	Vishay Dale
R7	7.32 k Ω resistor, 1%, 0805, 1/8W	ERJ-6ENF7321V	Panasonic
DIM, EN, MIN, MODE, VT	2.54 mm pitch, open top grip shunts	881545-2	TE Connectivity

Table 4. ADP8140 LED-EVALZ Components

Component	Description	Part Number	Manufacturer
DS1 to DS24	Neutral white XLamp LEDs	MLEAWT-A1-R250-0004E5	Cree Inc.
P1	2.54 mm pitch, 14-pin, double row, right angle, male pin header connector	610114249121	Würth Electronic
P2 to P13	2.54 mm pitch, 2-pin, single row, male pin header connectors	M20-8770246	Harwin Inc.
RNTC	NTC thermistor	CP18WF104D03RB	Murata Manufacturing
P10 to P13	2.54 mm pitch, open top grip shunts	881545-2	TE Connectivity

NOTES

**ESD Caution**

ESD (electrostatic discharge) sensitive device. Charged devices and circuit boards can discharge without detection. Although this product features patented or proprietary protection circuitry, damage may occur on devices subjected to high energy ESD. Therefore, proper ESD precautions should be taken to avoid performance degradation or loss of functionality.

Legal Terms and Conditions

By using the evaluation board discussed herein (together with any tools, components documentation or support materials, the "Evaluation Board"), you are agreeing to be bound by the terms and conditions set forth below ("Agreement") unless you have purchased the Evaluation Board, in which case the Analog Devices Standard Terms and Conditions of Sale shall govern. Do not use the Evaluation Board until you have read and agreed to the Agreement. Your use of the Evaluation Board shall signify your acceptance of the Agreement. This Agreement is made by and between you ("Customer") and Analog Devices, Inc. ("ADI"), with its principal place of business at One Technology Way, Norwood, MA 02062, USA. Subject to the terms and conditions of the Agreement, ADI hereby grants to Customer a free, limited, personal, temporary, non-exclusive, non-sublicensable, non-transferable license to use the Evaluation Board FOR EVALUATION PURPOSES ONLY. Customer understands and agrees that the Evaluation Board is provided for the sole and exclusive purpose referenced above, and agrees not to use the Evaluation Board for any other purpose. Furthermore, the license granted is expressly made subject to the following additional limitations: Customer shall not (i) rent, lease, display, sell, transfer, assign, sublicense, or distribute the Evaluation Board; and (ii) permit any Third Party to access the Evaluation Board. As used herein, the term "Third Party" includes any entity other than ADI, Customer, their employees, affiliates and in-house consultants. The Evaluation Board is NOT sold to Customer; all rights not expressly granted herein, including ownership of the Evaluation Board, are reserved by ADI. CONFIDENTIALITY. This Agreement and the Evaluation Board shall all be considered the confidential and proprietary information of ADI. Customer may not disclose or transfer any portion of the Evaluation Board to any other party for any reason. Upon discontinuation of use of the Evaluation Board or termination of this Agreement, Customer agrees to promptly return the Evaluation Board to ADI. ADDITIONAL RESTRICTIONS. Customer may not disassemble, decompile or reverse engineer chips on the Evaluation Board. Customer shall inform ADI of any occurred damages or any modifications or alterations it makes to the Evaluation Board, including but not limited to soldering or any other activity that affects the material content of the Evaluation Board. Modifications to the Evaluation Board must comply with applicable law, including but not limited to the RoHS Directive. TERMINATION. ADI may terminate this Agreement at any time upon giving written notice to Customer. Customer agrees to return to ADI the Evaluation Board at that time. LIMITATION OF LIABILITY. THE EVALUATION BOARD PROVIDED HEREUNDER IS PROVIDED "AS IS" AND ADI MAKES NO WARRANTIES OR REPRESENTATIONS OF ANY KIND WITH RESPECT TO IT. ADI SPECIFICALLY DISCLAIMS ANY REPRESENTATIONS, ENDORSEMENTS, GUARANTEES, OR WARRANTIES, EXPRESS OR IMPLIED, RELATED TO THE EVALUATION BOARD INCLUDING, BUT NOT LIMITED TO, THE IMPLIED WARRANTY OF MERCHANTABILITY, TITLE, FITNESS FOR A PARTICULAR PURPOSE OR NONINFRINGEMENT OF INTELLECTUAL PROPERTY RIGHTS. IN NO EVENT WILL ADI AND ITS LICENSORS BE LIABLE FOR ANY INCIDENTAL, SPECIAL, INDIRECT, OR CONSEQUENTIAL DAMAGES RESULTING FROM CUSTOMER'S POSSESSION OR USE OF THE EVALUATION BOARD, INCLUDING BUT NOT LIMITED TO LOST PROFITS, DELAY COSTS, LABOR COSTS OR LOSS OF GOODWILL. ADI'S TOTAL LIABILITY FROM ANY AND ALL CAUSES SHALL BE LIMITED TO THE AMOUNT OF ONE HUNDRED US DOLLARS (\$100,000). EXPORT. Customer agrees that it will not directly or indirectly export the Evaluation Board to another country, and that it will comply with all applicable United States federal laws and regulations relating to exports. GOVERNING LAW. This Agreement shall be governed by and construed in accordance with the substantive laws of the Commonwealth of Massachusetts (excluding conflict of law rules). Any legal action regarding this Agreement will be heard in the state or federal courts having jurisdiction in Suffolk County, Massachusetts, and Customer hereby submits to the personal jurisdiction and venue of such courts. The United Nations Convention on Contracts for the International Sale of Goods shall not apply to this Agreement and is expressly disclaimed.

©2019 Analog Devices, Inc. All rights reserved. Trademarks and registered trademarks are the property of their respective owners.
UG17297-0-8/19(0)



www.analog.com