

REVISION(S)			
LTR	DESCRIPTION	INIT	APP'D
O	ECN: 0S60-0237-04	E.T 9/24/04	B.P 10/6/04
A	ECR-06-022996	E.T 9/29/06	V.K 9/29/06

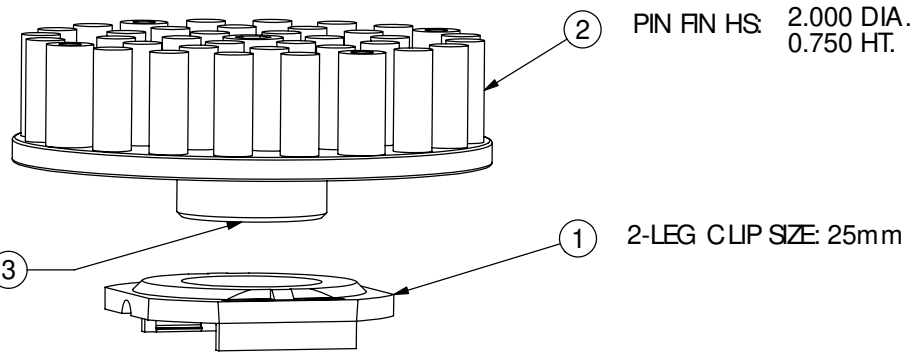

- MATERIAL:
HEAT SINK: ALUM. (BLACK ANODIZE)
CLIP: BLACK PEI (UL94-VO)
- BEFORE THE HEATSINK APPLICATION, THE USER SHOULD IDENTIFY THE SPECIFICATION OF MAXIMUM LOAD ON THE BGA PACKAGE.

HEATSINK TORQUE SPECIFICATIONS CONVERTED TO FORCE.

BARE DIE PACKAGE:
1.5 POUND-FORCE INCH TORQUE = 8.5 POUND-FORCE
(0.17 NEWTON TORQUE = 37.81 NEWTON)

2.0 POUND-FORCE INCH TORQUE = 11.4 POUND-FORCE
(0.23 NEWTON METER TORQUE = 50.71NEWTON)

FULL SIZE LID PACKAGE:
1.5 POUND-FORCE INCH TORQUE = 8.3 POUND-FORCE
(0.17 NEWTON TORQUE = 36.92NEWTON)

2.0 POUND-FORCE INCH TORQUE = 11.1 POUND-FORCE
(0.23 NEWTON METER TORQUE = 49.38NEWTON)
- REMOVE CLIP WITH REMOVAL TOOL P/N: 1542616-1.
- RoHS COMPLIANT AND CERTIFIED.

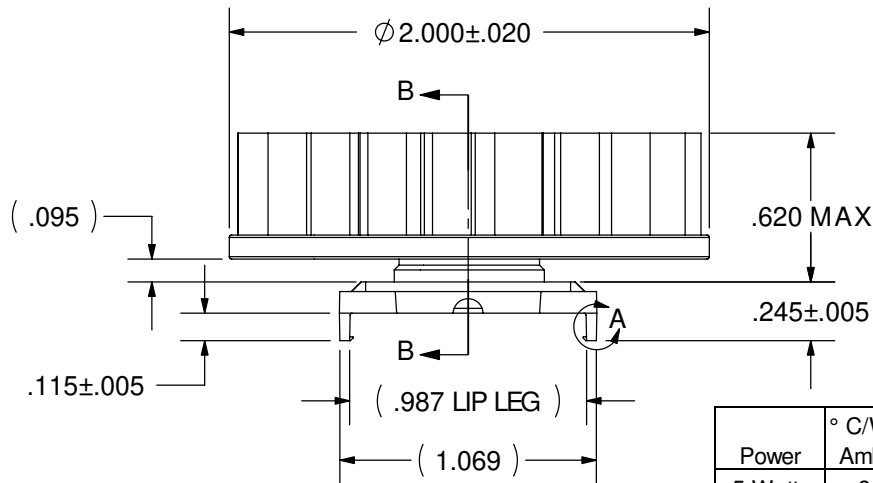
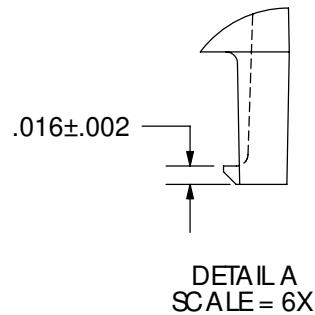

5/8 - 27 UNS-2A
THREAD

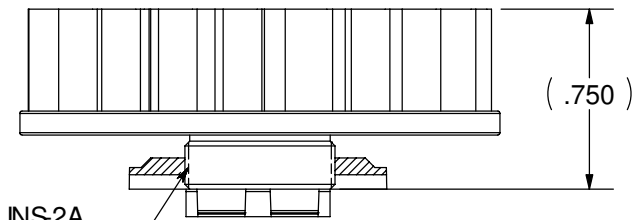

SECTION B-B

Power	° C/W @ Ambient	° C/W @ 200 LFM	° C/W @ 400 LFM	° C/W @ 600 LFM
5 Watts	8.85	4.55	3.45	2.55
10 Watts	7.97	4.52	3.39	2.45
15 Watts	7.41	4.57	3.34	2.42

CUSTOMER DRAWING

SPECIFICATIONS ARE SUBJECT TO CHANGE WITHOUT NOTICE

ITEM	DESCRIPTION	QTY
1	MOUNTING CLIP	1
2	HEAT SINK	1
3	INTERFACE	1

DO NOT SCALE	tyco / Electronics Attleboro Falls Massachusetts 02763			CONFIDENTIAL PROPERTY OF TYCO ELECTRONICS NOT TO BE DISCLOSED TO OTHERS REPRODUCED OR USED FOR ANY PURPOSES EXCEPT AS AUTHORIZED IN WRITING BY AN AUTHORIZED OFFICIAL OF TYCO. MUST BE RETURNED TO TYCO ON DEMAND, ON COMPLETION OF ORDERS OR OTHER PURPOSES FOR WHICH LENT.		TITLE 25mm PIN FIN HEATSINK ASSEMBLY (HTS285NF-U)				
	UNLESS OTHERWISE SPECIFIED TO LEFTRANCES ARE:		DRAWN BY: ETAO	DATE 9/24/04	MATERIAL: SEE NOTE		DIMENSIONS ARE IN: INCHES	SCALE: 1.25:1	PART NO: 5-1542001-4	SHEET: 1 OF 1
	.XX ± .XXX ± .XXXX ± ANGLES ± °		ENGINEER: B.PETROCELLI	DATE 10/6/04	FINISH: SEE NOTE			SIZE: A	DWG. NO. C-5-1542001-4	REV: A
			FILENAME	PROJECT	SYSTEM					