

DO NOT SCALE FROM THIS PRINT

LST-1XX-XX-XX-D

No OF POSITIONS

-02 THRU -30 (PER ROW)

LEAD STYLE

-07: USE T-1S6-07-XX-2 & C-15-02-XX

ROW SPECIFICATION

-D: DOUBLE (USE RTSW-50-D & LST-50-S)

PLATING SPECIFICATION

- S: SELECTIVE GOLD (USE T-1S6-07-S-2 & C-15-02-S)
- F: FLASH SELECTIVE GOLD (USE T-1S6-07-F-2 & C-15-02-F)
- G: GOLD (USE T-1S6-07-G-2 & C-15-02-G)
- T: TIN (USE T-1S6-07-T-2 & C-15-02-T)
- SM: SELECTIVE HEAVY GOLD, MATTE TIN TAIL (USE T-1S6-07-S-2 & C-15-02-S)
- FM: FLASH SELECTIVE GOLD, MATTE TIN TAIL (USE T-1S6-07-F-2 & C-15-02-F)
- TM: MATTE TIN (USE T-1S6-07-T-2 & C-15-02-T)

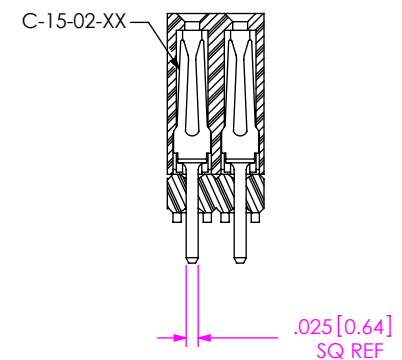
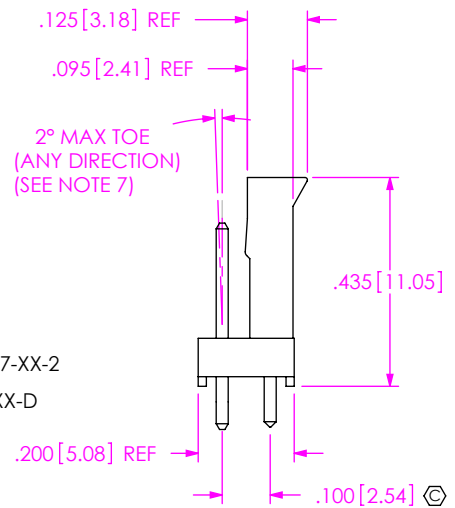
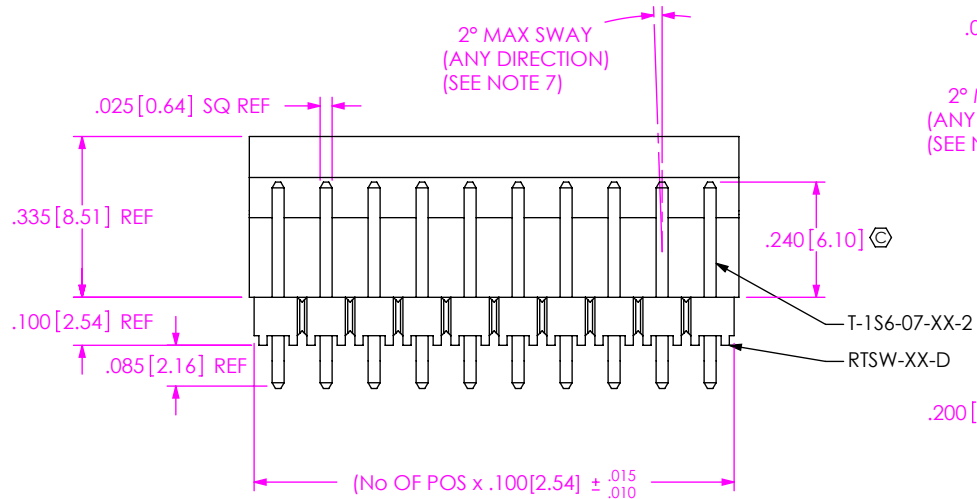
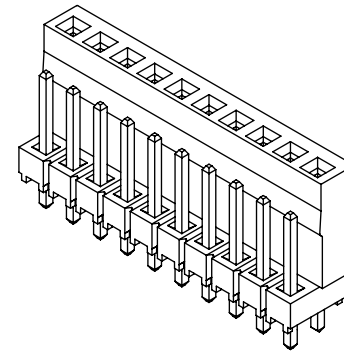
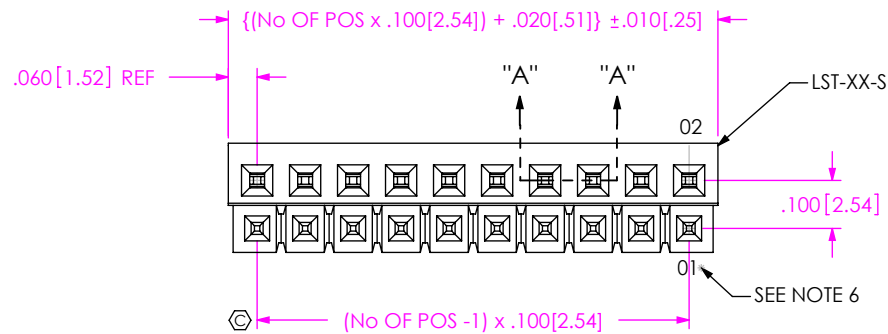

SECTION "A"- "A"

NOTES:

1. Ⓢ REPRESENTS A CRITICAL DIMENSION.
2. BURR ALLOWANCE: .0015[.038] MAX.
3. MAXIMUM CUT FLASH: .010[.25].
4. MINIMUM PUSHOUT FORCE: 2 LBS.
5. MAXIMUM ALLOWABLE BOW: .002 INCH/INCH AFTER ASSEMBLY.
6. PIN 01 WILL MATE WITH CONTACT 02 ON MATING CONNECTOR.
7. SWAY AND TOE SPEC. OF 2° APPLIES TO ALL POSITIONS, POST AND TAIL, IN ALL DIRECTIONS.
8. PARTS TO BE BULK PACKAGED.
9. TSW-50-D MAY BE USED IF RTSW-50-D IS NOT AVAILABLE.
- Ⓢ10. T-1S6-07-T-2 MUST BE FILLED IN THE SAME WAY AS THE SELECTIVE PLATED PINS TO REDUCE THE NUMBER OF BAND MARKS IN THE POST AREA.

<p>UNLESS OTHERWISE SPECIFIED, DIMENSIONS ARE IN INCHES. TOLERANCES ARE:</p> <p>DECIMALS ANGLES</p> <p>.XX: ±.01 [.3] 2°</p> <p>.XXX: ±.005 [.13]</p> <p>.XXXX: ±.0020 [.051]</p>	<p>PROPRIETARY NOTE</p> <p>THIS DOCUMENT CONTAINS CONFIDENTIAL AND PROPRIETARY INFORMATION AND ALL DESIGN, MANUFACTURING, REPRODUCTION, USE, PATENT RIGHTS AND SALES RIGHTS ARE EXPRESSLY RESERVED BY SAMTEC, INC. THIS DOCUMENT SHALL NOT BE DISCLOSED, IN WHOLE OR PART, TO ANY UNAUTHORIZED PERSON OR ENTITY NOR REPRODUCED, TRANSFERRED OR INCORPORATED IN ANY OTHER PROJECT IN ANY MANNER WITHOUT THE EXPRESS WRITTEN CONSENT OF SAMTEC, INC.</p>	 <p>520 PARK EAST BLVD. NEW ALBANY, IN 47150 PHONE: 812-944-6733 FAX: 812-948-5047 e-Mail: info@SAMTEC.com code: 55322</p>
	<p>DO NOT SCALE DRAWING SHEET SCALE: 2.5:1</p> <p>MATERIAL: RTSW-50-D: CRASTIN SK652 FR COLOR: BLACK LST-50-S: VECTRA E130I, COLOR: BLACK T-1S6-07-XX-2 & C-15-02-XX: PHOS BRONZE</p>	
<p>F:\DWG\MISC\MKTG\LST-1XX-XX-XX-D-MKT.SLDDRW</p>		<p>BY: KEVIN B 10/20/00 SHEET 1 OF 2</p>

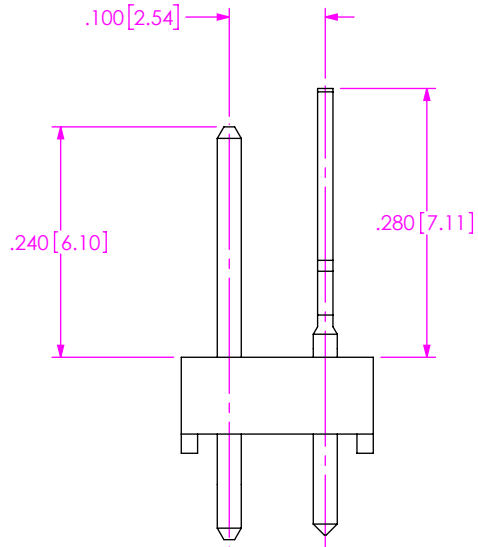

IN PROCESS 1

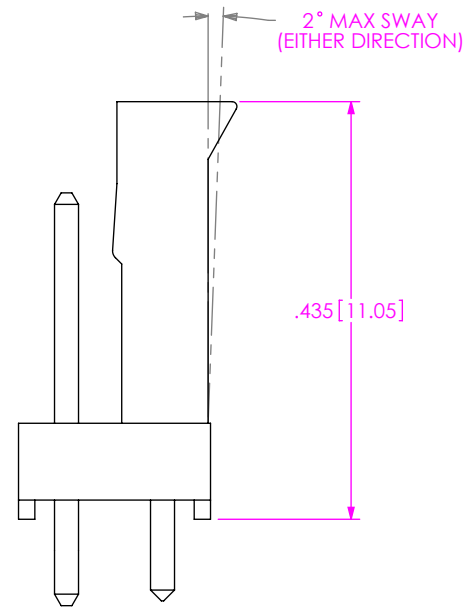

IN PROCESS 2

1. LOAD FULL STRIP RTSW-50-D WITH T-1S6-07-XX-2 AND C-15-02-XX TO DIMENSIONS SHOWN ON INPROCESS 1.
2. MULTI-CUT RTSW-50-D ASSEMBLY TO POSITION.
3. ROTO-CUT LST-50-S BODY TO POSITION.
4. MOUNT LST-XX-S TO RTSW-XX-D TO DIMENSION SHOWN ON INPROCESS 2.

PROPRIETARY NOTE

THIS DOCUMENT CONTAINS INFORMATION CONFIDENTIAL AND PROPRIETARY TO SAMTEC, INC. AND SHALL NOT BE REPRODUCED OR TRANSFERRED TO OTHER DOCUMENTS OR DISCLOSED TO OTHERS OR USED FOR ANY PURPOSE OTHER THAN THAT WHICH IT WAS OBTAINED WITHOUT THE EXPRESSED WRITTEN CONSENT OF SAMTEC, INC.

DO NOT SCALE DRAWING

SHEET SCALE: 5:1

samtec

520 PARK EAST BLVD, NEW ALBANY, IN 47150
 PHONE: 812-944-6733 FAX: 812-948-5047
 e-Mail: info@SAMTEC.com code: 55322

DESCRIPTION:
 .100 C.L. TERMINAL / SOCKET COMBO

DWG. NO. **LST-1XX-XX-XX-D**

BY: KEVIN B 10/20/00 SHEET 2 OF 2