

Solar power station PV-12W

Technical specifications

Document version V1.0

Released: 6.2021

Content

1 Product overview 3

 1.1 Product introduction 3

 1.2 Product features 3

 1.3 Product specifications 5

2 Product details..... 5

 2.1 Solar modules 5

3 Product appearance 6

4 Equipment list..... 7

1 Product overview

1.1 Product introduction

In recent years, the development of cheaper and better solar power has allowed the construction of outdoor monitoring systems that are not connected to the grid and instead use solar energy.

The use of solar power brings many benefits. Solar energy does not require a connection to the power grid or the installation of expensive cables. After purchasing and installing solar power supply systems electricity gets produced by the sun for free, and the system require little maintenance, and are environmental friendly.

Outdoor environmental monitoring systems can be used for power line monitoring, natural disaster prevention, and early warning, river monitoring, smart agriculture, construction, traffic monitoring , bridge and road monitoring.

The new solar power supply system can solve the problems of electricity supply in remote areas. Including the high cost of electricity, expensive cables and the continuous operation and maintenance

- Convenient access to electricity: no need to install poles and cables, the system scale is arbitrary and supports customization;
- Low electricity cost: Solar energy is used as a power source, with the sun providing free electricity in abundance;
- Easy installation: plug and play, seamless access, rapid deployment;
- Efficient operation and maintenance: Modular design, convenient disassembly and maintenance, no requirement for constant personnel on duty.

1.2 Product features

This product is composed of photovoltaic panels:

- Long life: high-efficiency crystalline silicon components, with a life of more than 15 years, and high-quality long-life iron-lithium batteries;
- High reliability: The system can withstand typhoons, hail and humidity, and runs stable even in the harshest environment.
- No on-duty personnel required: There is no on-duty personnel required, and the device continuously supplies power like conventional energy systems;
- DC interference-free power supply: solar battery power generation system, no noise, power supply without high-order harmonic interference, especially suitable for backup power supply;

➤ Not affected by geographical features: can operate in areas such as plains, rivers, oceans, mountains, snowfields, islands, forests, etc.

This power generation system can be used wherever electricity is needed.

1.3 Product specifications

Solar panel parameters	Module type	Monocrystalline silicon
	Peak power	12Wp
	Open circuit voltage	14V
	Short circuit current	1A
	Package size	350mm*250mm*25mm
	Package weight	around 1.1kg

2 Product details

2.1 Solar modules

Product name: 12W photovoltaic panel

Main features:

- High-efficiency monocrystalline silicon cells, conversion efficiency>19%
- Attenuation rate <5% within 2 years
- Attenuation rate <10% within 10 years
- Excellent low light power generation performance
- light aluminium alloy frame, sturdy and durable
- Unique technology to avoid freezing and deformation through water in the frame
- Can withstand 5400Pa snow load and 2400Pa wind pressure

Technical Parameters:

Technical Parameters of Photovoltaic Modules		
Solar cell type		Monocrystalline silicon
Index	Unit	Data
Peak power	Wp	12
Open circuit voltage(Voc)	V	14
Short circuit current (Isc)	A	1
Working voltage (Vmppt)	V	12
Working current (Imppt)	A	1
maximum voltage the system can withstand	Vdc	1000
Module size	mm	350*250*25
Peak power temperature coefficient	%/°C	-0.45
Open circuit voltage temperature coefficient	%/°C	-0.35
Short-circuit current temperature coefficient	%/°C	+0.05
Operating temperature range	°C	-20~70
Maximum wind/snow load	Pa	2400/5400

3 Product appearance

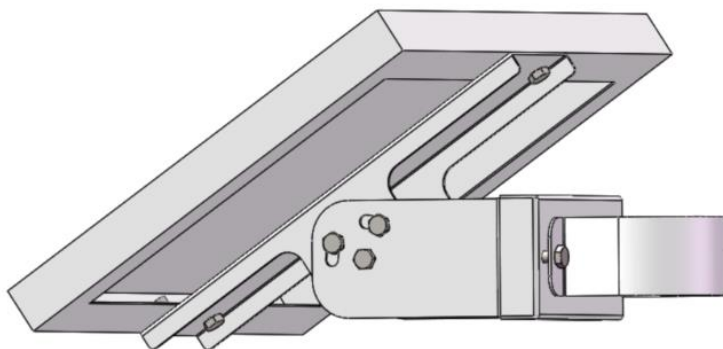

4 Equipment list

Item	Name	Specification	Quantity	Remarks
1	Photovoltaic module	12W solar panel with 1.5m cable and six core plugs: 1. Photovoltaic panel orientation: red + black 2. Six-pin plug: red connects to 2 pins, black connects to 5 pins	1	Right-angle single crystal silicon Note: the wiring diagram for details
2	Stand	Equipment to install the solar panel	1	
3	Packing box	Customized according to the size	1	

Wiring diagram

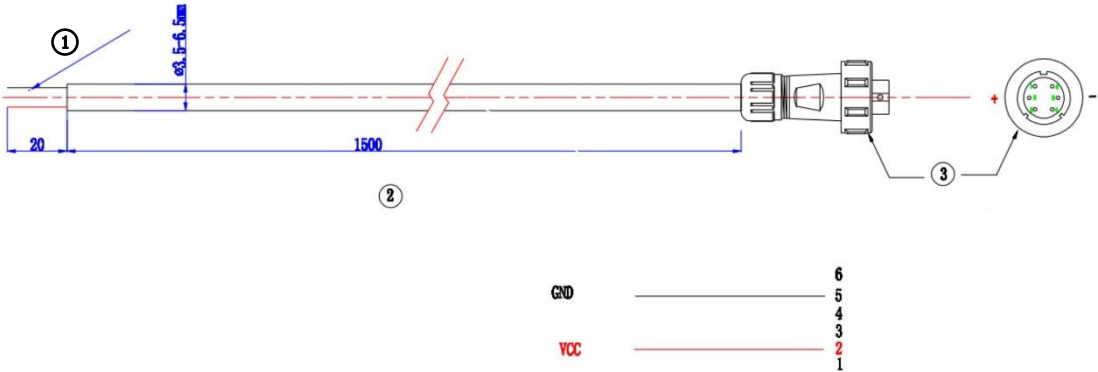

- 1.) 6mm thread ends
- 2.) Cable
- 3.) Cable plug - 6pin