

Document Title

1M x 8 bit Super Low Power and Low Voltage Full CMOS Static RAM

Revision History

Revision No.	History	Date	Remark
0.0	-. Initial Draft	Aug. 7 2013	Preliminary

FEATURES

- Process Technology : 0.15 μ m Full CMOS
- Organization : 1M x 8 bit
- Power Supply Voltage : 2.7V ~ 3.6V
- Low Data Retention Voltage : 1.5V(Min.)
- Three state output and TTL Compatible
- Package Type : 48-FPBGA, 44-TSOP2

GENERAL DESCRIPTION

The AS6C8008A families are fabricated by Alliance Memory's advanced full CMOS process technology. The families support industrial temperature range and Chip Scale Package for user flexibility of system design. The families also supports low data retention voltage for battery back- up operation with low data retention current.

PRODUCT FAMILY

Product Family	Operating Temperature	Vcc Range	Speed	Power Dissipation		PKG Type
				Standby (I_{SB1} , Typ.)	Operating (I_{CC1} ·Max.)	
AS6C8008A-45BIN	Industrial (-40 ~ 85°C)	2.7 ~ 3.6 V	45 ns	2 A ¹⁾	4 mA	48-FPBGA
AS6C8008A-45ZIN						44-TSOP2

¹⁾Typical values are measured at Vcc=3.3V, T_A=25°C and not 100% tested.

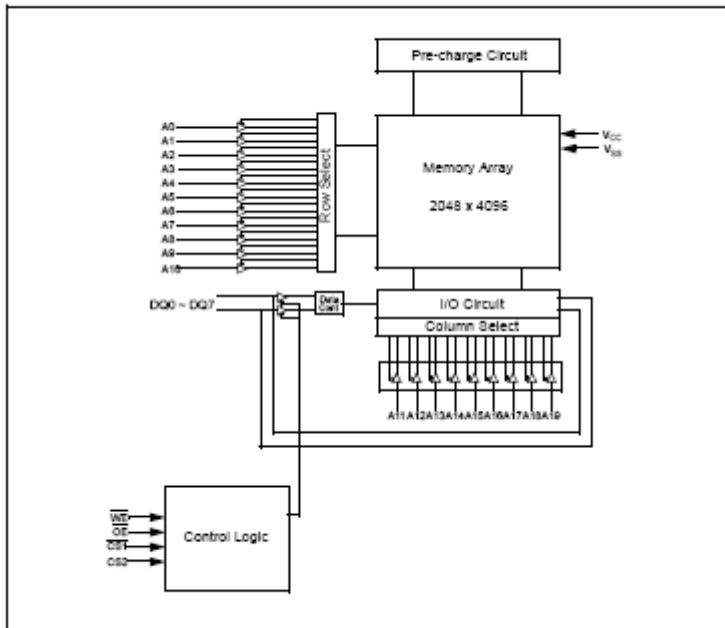
FUNCTIONAL BLOCK DIAGRAM

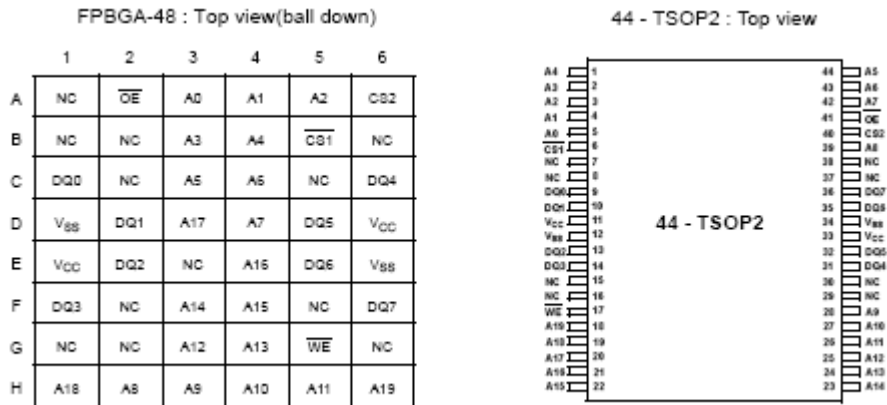
PIN CONFIGURATIONS

PIN DESCRIPTION

Name	Function	Name	Function
$\overline{CS1}$, $\overline{CS2}$	Chip Select inputs	V_{CC}	Power Supply
\overline{OE}	Output Enable input	V_{SS}	Ground
\overline{WE}	Write Enable input	NC	No Connection
A0~A19	Address inputs		
DQ0~DQ7	Data inputs/outputs		

ABSOLUTE MAXIMUM RATINGS¹⁾

Parameter	Symbol	Ratings	Unit
Voltage on Any Pin Relative to Vss	V_{IN}, V_{OUT}	-0.2 to 4.0	V
Voltage on Vcc supply relative to Vss	V_{CC}	-0.2 to 4.0	V
Power Dissipation	P_D	1.0	W
Operating Temperature	T_A	-40 to 85	°C

1. Stresses greater than those listed under “nav” may cause permanent damage to the device. Functional operation should be restricted to recommended operating condition. Exposure to absolute maximum rating conditions for extended periods may affect reliability.

FUNCTIONAL DESCRIPTION

$\overline{CS1}$	$\overline{CS2}$	\overline{OE}	\overline{WE}	DQ0~7	Mode	Power
H	X	X	X	High-Z	Deselected	Stand by
X	L	X	X	High-Z	Deselected	Stand by
L	H	H	H	High-Z	Output Disabled	Active
L	H	L	H	Data Out	Read	Active
L	H	X	L	Data In	Write	Active

NOTE : X means don't care. (Must be low or high state)

RECOMMENDED DC OPERATING CONDITIONS ¹⁾

Parameter	Symbol	Min	Typ	Max	Unit
Supply voltage	V_{CC}	2.7	3.3	3.6	V
Ground	V_{SS}	0	0	0	V
Input high voltage	V_{IH}	2.2	-	$V_{CC} + 0.2^{2)}$	V
Input low voltage	V_{IL}	$-0.2^{3)}$	-	0.6	V

1. $T_A = -40$ to 85°C , otherwise specified
2. Overshoot: $V_{CC} + 2.0$ V in case of pulse width $\leq 20\text{ns}$
3. Undershoot: -2.0 V in case of pulse width $\leq 20\text{ns}$
4. Overshoot and undershoot are sampled, not 100% tested.

CAPACITANCE ¹⁾ ($f = 1\text{MHz}$, $T_A = 25^\circ\text{C}$)

Item	Symbol	Test Condition	Min	Max	Unit
Input capacitance	C_{IN}	$V_{IN} = 0\text{V}$	-	8	pF
Input/Output capacitance	C_{IO}	$V_{IO} = 0\text{V}$	-	10	pF

1. Capacitance is sampled, not 100% tested

DC AND OPERATING CHARACTERISTICS

Parameter	Symbol	Test Conditions	Min	Typ	Max	Unit	
Input leakage current	I_{LI}	$V_{IN}=V_{SS}$ to V_{CC}	-1	-	1	μA	
Output leakage current	I_{LO}	$\overline{CS1}=V_{IH}$ or $\overline{CS2}=V_{IL}$ or $\overline{OE}=V_{IH}$ or $\overline{WE}=V_{IL}$, $V_{IO}=V_{SS}$ to V_{CC}	-1	-	1	μA	
Operating power supply	I_{CC}	$I_{IO}=0mA$, $\overline{CS1}=V_{IL}$, $\overline{CS2}=\overline{WE}=V_{IH}$, $V_{IN}=V_{IH}$ or V_{IL}	-	-	2	mA	
Average operating current	I_{CC1}	Cycle time=1 s, 100% duty, $I_{IO}=0mA$, $\overline{CS1}\leq 0.2V$, $\overline{CS2}\geq V_{CC}-0.2V$, $V_{IN}\leq 0.2V$ or $V_{IN}\geq V_{CC}-0.2V$	-	-	4	mA	
	I_{CC2}	Cycle time = Min, $I_{IO}=0mA$, 100% duty, $\overline{CS1}=V_{IL}$, $\overline{CS2}=V_{IH}$, $V_{IN}=V_{IL}$ or V_{IH}	45ns	-	-	45	mA
			70ns	-	-	25	
Output low voltage	V_{OL}	$I_{OL} = 2.1mA$	-	-	0.4	V	
Output high voltage	V_{OH}	$I_{OH} = -1.0mA$	2.4	-	-	V	
Standby Current (TTL)	I_{SB}	$\overline{CS1}=V_{IH}$, $\overline{CS2}=V_{IL}$, Other inputs= V_{IH} or V_{IL}	-	-	0.5	mA	
Standby Current (CMOS)	I_{SB1}	$\overline{CS1}\geq V_{CC}-0.2V$, $\overline{CS2}\geq V_{CC}-0.2V$ (CS1 controlled) or $0V\leq\overline{CS2}\leq 0.2V$ (CS2 controlled), Other inputs = $0\sim V_{CC}$ (Typ. condition : $V_{CC}=3.3V$ @ $25^{\circ}C$) (Max. condition : $V_{CC}=3.6V$ @ $85^{\circ}C$)	LF	-	2.1	15	μA

1. Typical values are measured at $V_{CC}=3.3V$, $T_A=25^{\circ}C$ and not 100% tested.

AC OPERATING CONDITIONS

Test Conditions (Test Load and Test Input/Output Reference)

Input Pulse Level : 0.4 to 2.4V

Input Rise and Fall Time : 5ns

Input and Output reference Voltage : 1.5V

 Output Load (See right) : $CL^{(1)} = 100pF + 1\ TTL(70nsec)$
 $CL^{(1)} = 30pF + 1\ TTL(45ns/55ns)$

1. Including scope and Jig capacitance
2. $R_1=3070\Omega$, $R_2=3150\Omega$
3. $V_{TM}=2.8V$
4. $CL = 5pF + 1\ TTL$ (measurement with t_{LZ} , t_{HZ} , t_{OLZ} , t_{OHZ} , t_{WHZ})

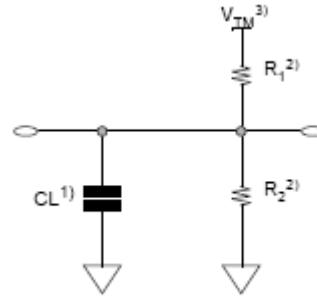

READ CYCLE ($V_{CC}=2.7$ to $3.6V$, $Gnd = 0V$, $T_A = -40^{\circ}C$ to $+85^{\circ}C$)

Parameter	Symbol	45ns		Unit
		Min	Max	
Read cycle time	t_{RC}	45	-	ns
Address access time	t_{AA}	-	45	ns
Chip select to output	t_{CO1} , t_{CO2}	-	45	ns
Output enable to valid output	t_{OE}	-	30	ns
Chip select to low-Z output	t_{LZ1} , t_{LZ2}	5	-	ns
Output enable to low-Z output	t_{OLZ}	5	-	ns
Chip disable to high-Z output	t_{HZ1} , t_{HZ2}	0	20	ns
Output disable to high-Z output	t_{OHZ}	0	20	ns
Output hold from address change	t_{OH}	10	-	ns

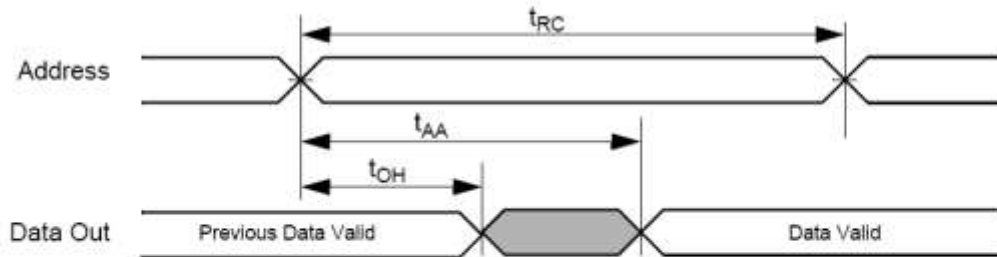
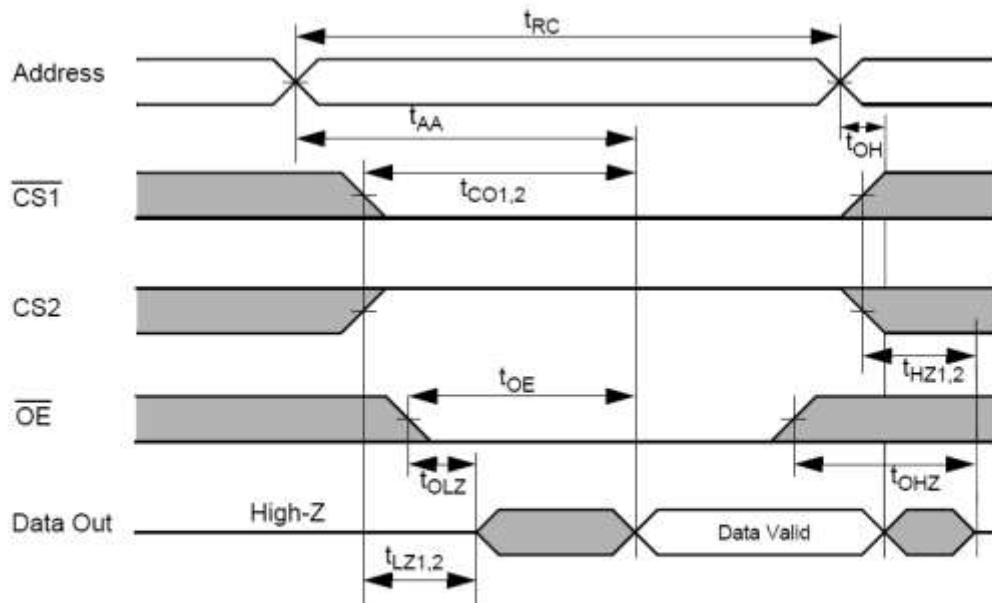
Parameter	Symbol	45ns		Unit
		Min	Max	
Write cycle time	t_{WC}	45	-	ns
Chip select to end of write	t_{CW1} , t_{CW2}	45	-	ns
Address setup time	t_{AS}	0	-	ns
Address valid to end of write	t_{AW}	45	-	ns
Write pulse width	t_{WP}	45	-	ns
Write recovery time	t_{WR}	0	-	ns
Write to output high-Z	t_{WHZ}	0	20	ns
Data to write time overlap	t_{DW}	25		ns
Data hold from write time	t_{DH}	0	-	ns
End write to output low-Z	t_{OW}	5	-	ns

TIMING DIAGRAMS
TIMING WAVEFORM OF READ CYCLE(1) (Address Controlled, $\overline{CS1}=\overline{OE}=V_{LL}$, $CS2=\overline{WE}=V_{IH}$)

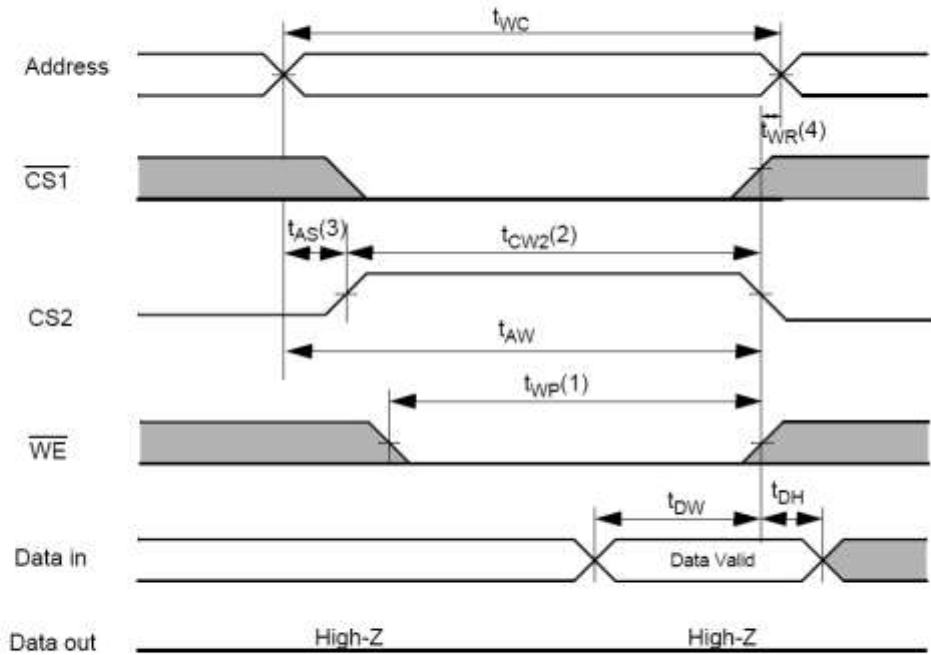
TIMING WAVEFORM OF READ CYCLE(2) ($\overline{WE} = V_{IH}$)

NOTES (READ CYCLE)

- $t_{HZ1,2}$ and t_{OHZ} are defined as the outputs achieve the open circuit conditions and are not referenced to output voltage levels.
- At any given temperature and voltage condition, $t_{HZ1,2}(\text{Max.})$ is less than $t_{LZ1,2}(\text{Min.})$ both for a given device and from device to device interconnection.

TIMING WAVEFORM OF WRITE CYCLE(3) (CS2 Controlled)

NOTES (WRITE CYCLE)

1. A write occurs during the overlap (t_{WP}) of low $\overline{CS1}$, a high CS2 and low \overline{WE} . A write begins at the latest transition among $\overline{CS1}$ goes low, CS2 goes high and \overline{WE} goes low. A write ends at the earliest transition among $\overline{CS1}$ goes high, CS2 goes low and \overline{WE} goes high. The t_{WP} is measured from the beginning of write to the end of write.
2. t_{CW} is measured from the $\overline{CS1}$ going low or CS2 going high to end of write.
3. t_{AS} is measured from the address valid to the beginning of write.
4. t_{WR} is measured from the end of write to the address change. t_{WR} applied in case a write ends as $\overline{CS1}$ or \overline{WE} going high or CS2 going low.

DATA RETENTION CHARACTERISTICS

Parameter	Symbol	Test Condition	Min	Typ	Max	Unit
V _{CC} for Data Retention	V _{DR}	I _{SB1} Test Condition (Chip Disabled) ¹⁾	1.5	-	3.6	V
Data Retention Current	I _{DR}	V _{CC} =1.5V, I _{SB1} Test Condition (Chip Disabled) ¹⁾	-	-	4	μA
Chip Deselect to Data Retention Time	t _{SDR}	See data retention wave form	0	-	-	ns
Operation Recovery Time	t _{RDR}		t _{RC}	-	-	

NOTES

- See the I_{SB1} measurement condition of datasheet page 5.

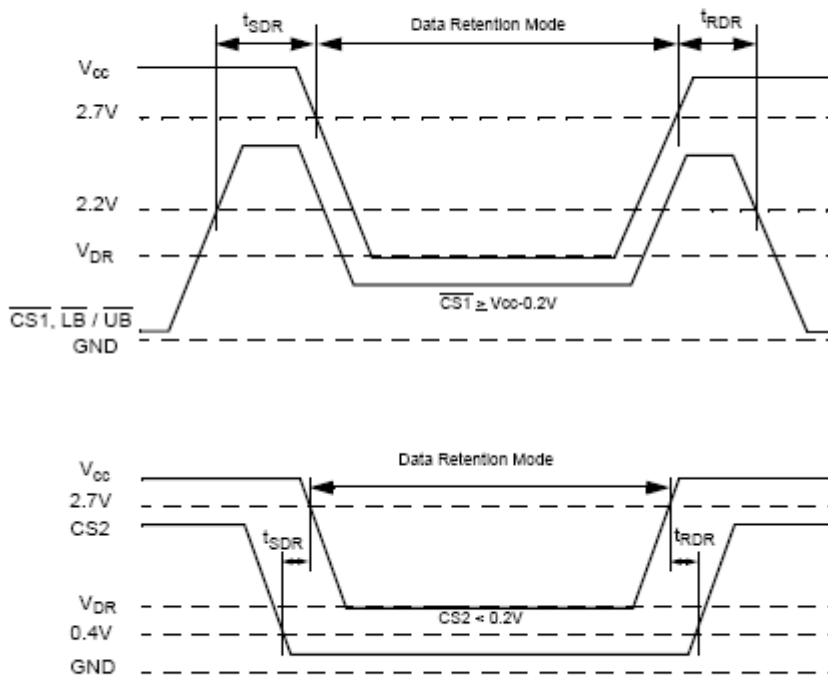
DATA RETENTION WAVE FORM

PACKAGE DIMENSION

44 - TSOP2 (0.8mm pin pitch)

44 PIN THIN SMALL OUTLINE PACKAGE TYPE II (400F)

Unit : millimeters / inches

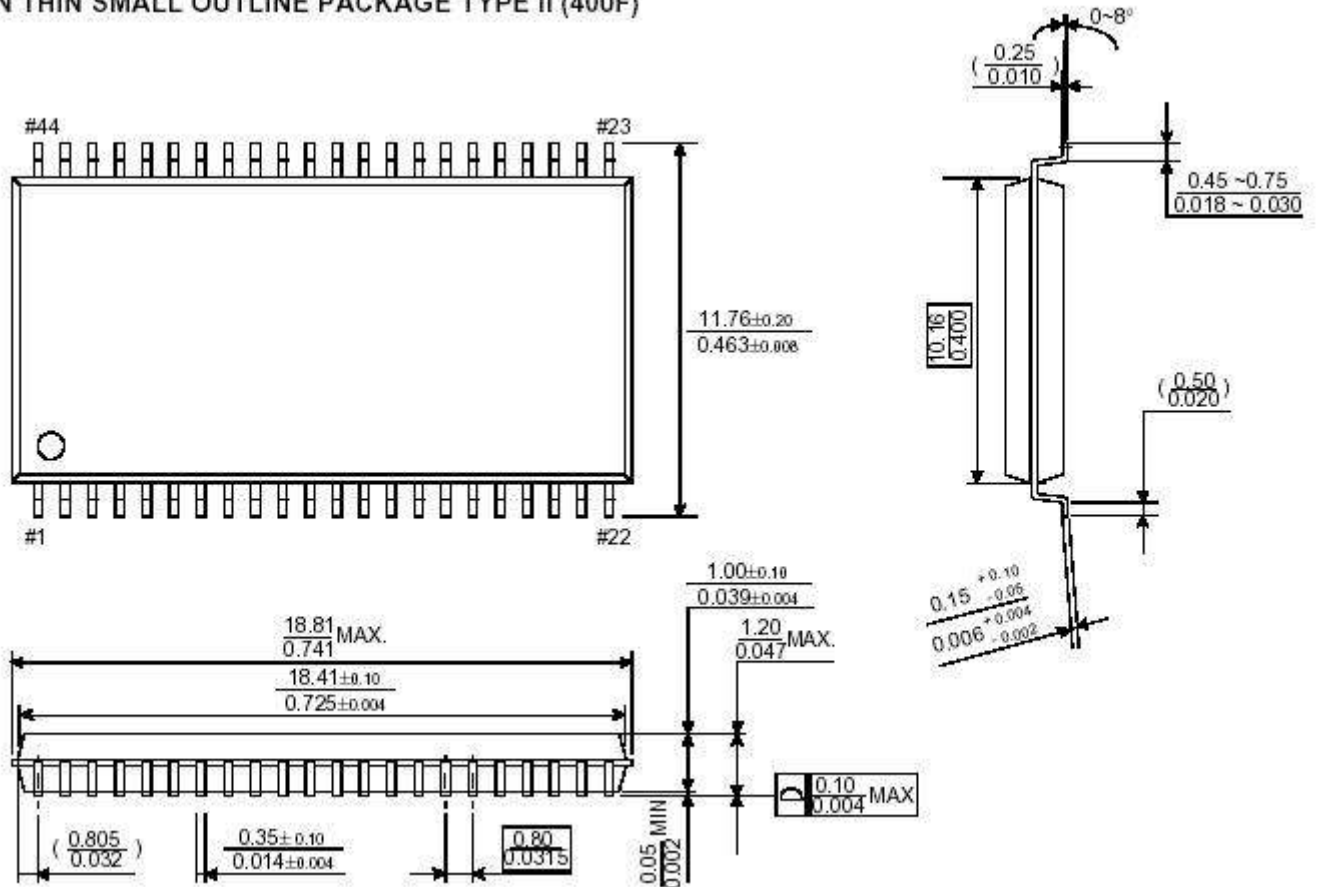

B	7.95	8.00	8.05
B1	-	3.75	-
C	9.95	10.00	10.05
C1	-	5.25	-
D	0.30	0.35	0.40
E	-	-	1.00
E1	-	-	0.70

NOTES.

1. Bump counts : 48(8row x 6column)
2. Bump pitch : (x,y)=(0.75x0.75) (typ.)
3. All tolerance are +/-0.050 unless otherwise specified.
4. Typ : Typical
5. Y is coplanarity : 0.08(Max)

48 Ball Fine Pitch BGA (0.75mm ball pitch)

Unit: millimeters

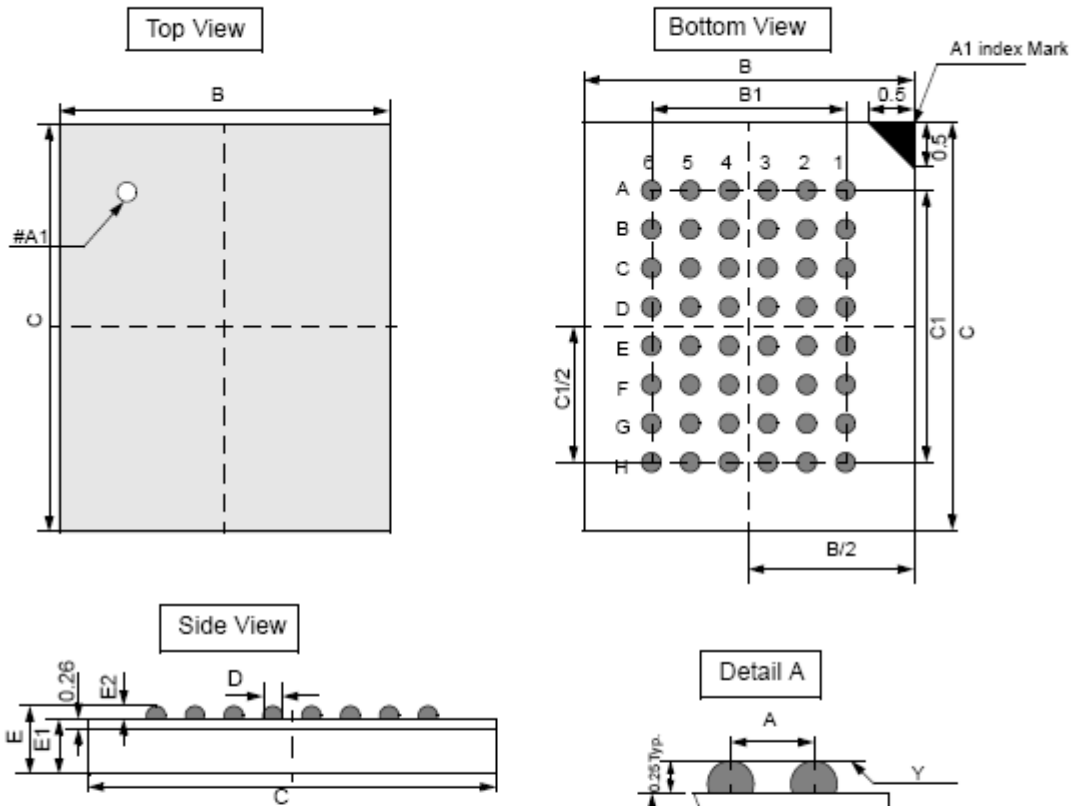

	Min	Typ	Max
A	-	0.75	-
B	7.95	8.00	8.05
B1	-	3.75	-
C	9.95	10.00	10.05
C1	-	5.25	-
D	0.30	0.35	0.40
E	-	-	1.00
E1	-	-	0.70
E2	0.20	0.25	0.30
Y	-	-	0.08

NOTES.

1. Bump counts : 48(8row x 6column)
2. Bump pitch : (x,y)=(0.75x0.75) (typ.)
3. All tolerance are +/-0.050 unless otherwise specified.
4. Typ : Typical
5. Y is coplanarity : 0.08(Max)