

THIS DRAWING IS UNPUBLISHED. RELEASED FOR PUBLICATION  
 © COPYRIGHT BY TYCO ELECTRONICS CORPORATION. ALL INTERNATIONAL RIGHTS RESERVED.

LOC		DIST		REVISIONS			
P	LTR	DESCRIPTION		DATE	DWN	APVD	
AG	0	G1		REVISED PER ECO-09-008864	11JUN09	DH MB	

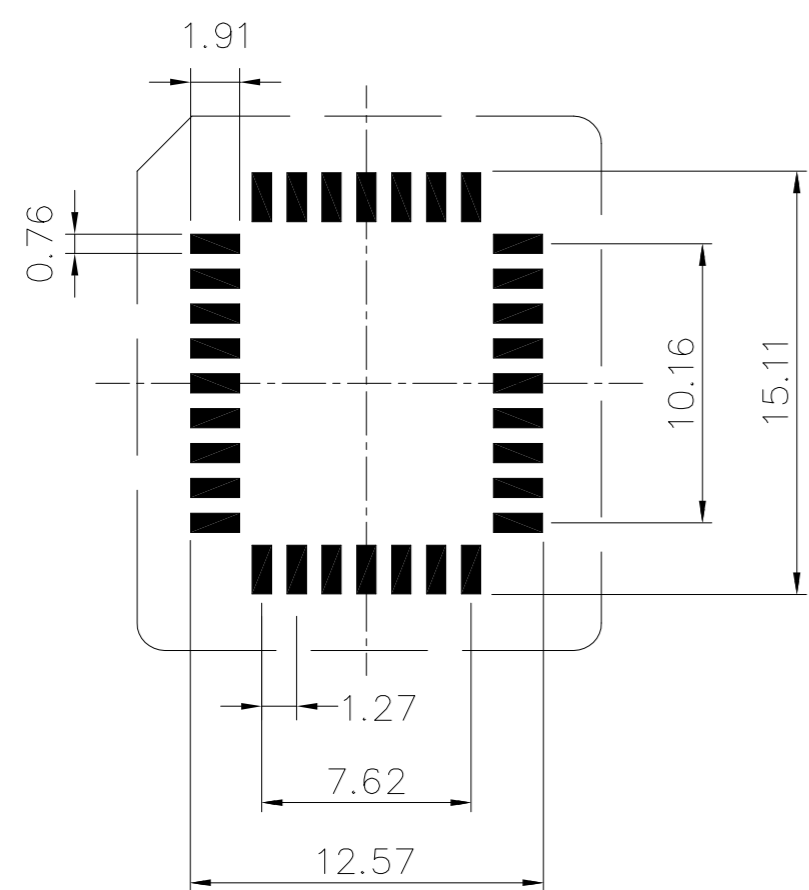
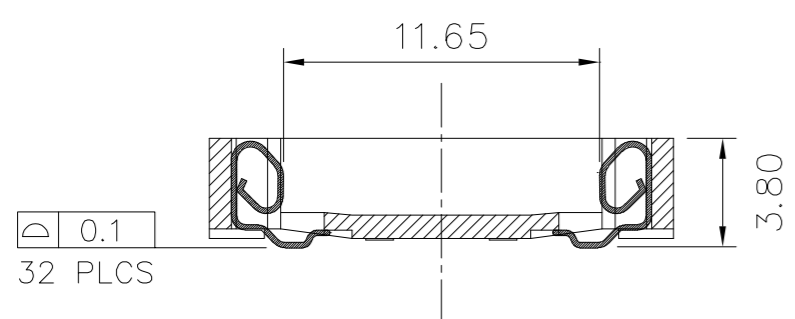
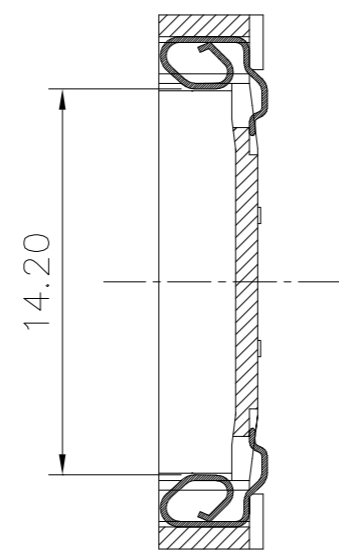
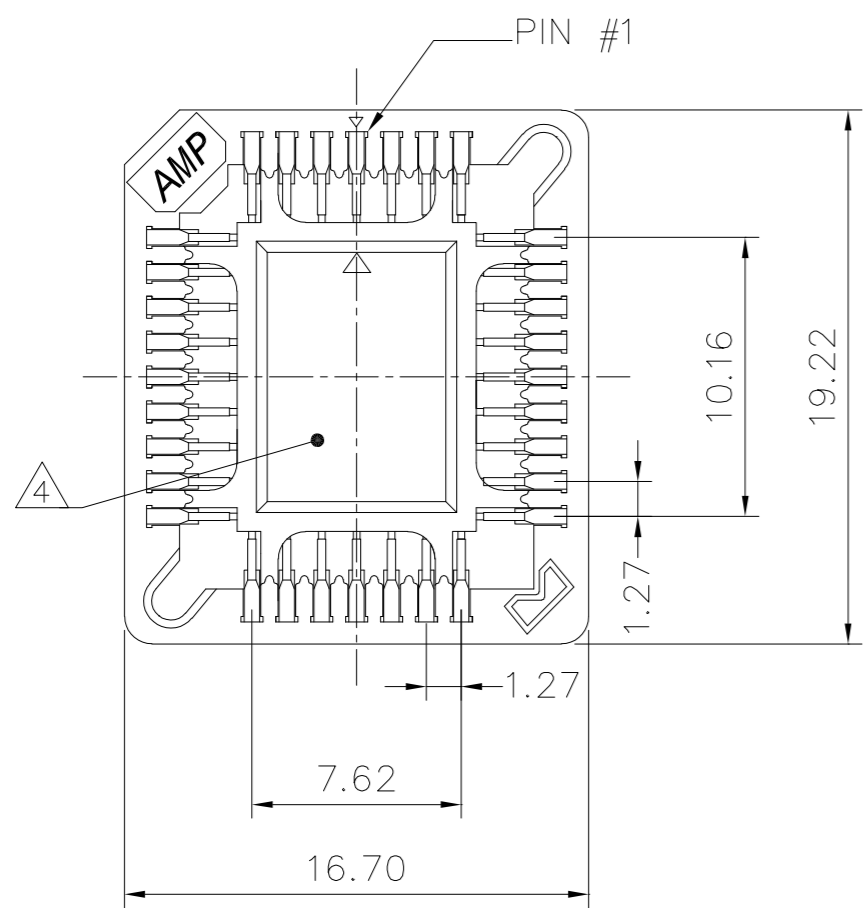

P.C.B. LAYOUT

- 1 MATERIALS:  
HOUSING - HIGH TEMPERATURE THERMOPLASTIC, UL94V-0, COLOR: BROWN.  
CONTACT - PHOSPHOR BRONZE.
- 2 FINISH, CONTACT: 0.0038 MIN 100% TIN OVER 0.0011 MIN NICKEL.
- 3. PLCC DEVICE SHALL CONFORM TO JEDEC STANDARD MS-016.
- 4 HOUSING FLOOR TO BE SMOOTH WITHIN A 5.20 DIAMETER FOR VACUUM PLACEMENT.
- 5 TAPE PACKAGING TO CONFORM TO EIA RS-481-3. TAPE WIDTH SHALL BE 32mm, TAPE PITCH SHALL BE 24mm, AND REEL DIAMETER SHALL BE 330mm.
- 6. PLCC EXTRACTION TOOL: AMP PART NUMBER 821980-1 OR 822476-1.
- 7. PRODUCT DESIGN OBJECTIVES:  
CURRENT RATING: 1 AMP, MAXIMUM  
CONTACT RESISTANCE: 20 MILLIOHMS, MAXIMUM  
DIELECTRIC WITHSTAND VOLTAGE: 600VAC, RMS, MINIMUM  
INSULATION RESISTANCE: 5,000 MEGOHMS, MINIMUM  
DURABILITY: 25 CYCLES  
OPERATING TEMPERATURE RANGE: -55 TO +105C  
MATING FORCE: 9.0 Kg, MAXIMUM
- 8 FINISH, CONTACT: 0.0038 MIN 93/7 TIN-LEAD OVER 0.0011 MIN NICKEL.
- 9 TUBE LENGTH 535mm. EXTERNAL CARTON 580 x 240 x 260mm TO HOLD 8,008 PIECES.
- 10 OBSOLETE PART NUMBER.

NOTES	FINISH	TUBES OR REELS/BOX	PCS/REEL OR TUBE	PACKAGING STYLE	AMP PART NUMBER
-	2 9	308	26	TUBES	822475-3
-	2 5	5	500	TAPE AND REEL	822475-2
10	8 5	5	500	TAPE AND REEL	822475-1

THIS DRAWING IS A CONTROLLED DOCUMENT.		DWN A. HOLT 19OCT99	Tyco Electronics Corporation Harrisburg, PA 17105-3608	
DIMENSIONS: mm	TOLERANCES UNLESS OTHERWISE SPECIFIED:	CHK K. KREIDLER 18OCT99	NAME SOCKET, MINI-PLCC, SURFACE MOUNT, 32 POSITION	
	0 PLC ± -	APVD K. KREIDLER 18OCT99	SIZE	CAGE CODE
	1 PLC ± -	PRODUCT SPEC	A2	00779
	2 PLC ± 0.20	APPLICATION SPEC	SCALE	DRAWING NO
	3 PLC ± -	FINISH	3:1	822475
	4 PLC ± -	WEIGHT	SHEET	1 OF 1
	ANGLES ± -	CUSTOMER DRAWING	REV	G1
MATERIAL - 1	SEE TABLE	REVISIONS		

822475