

6

5

4

3

2

1

E

E

D

D

C

C

B

B

A

A

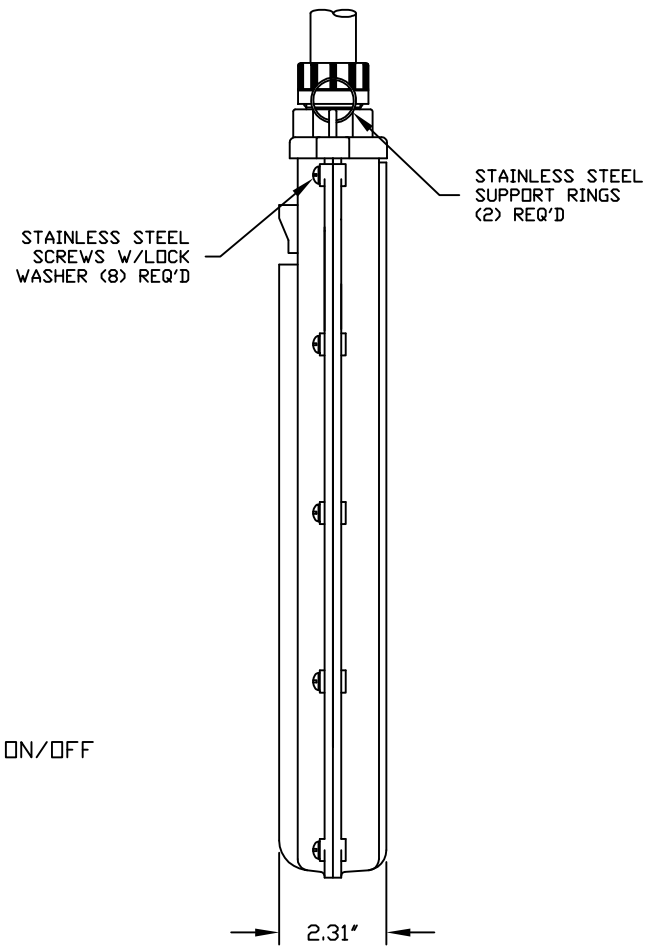
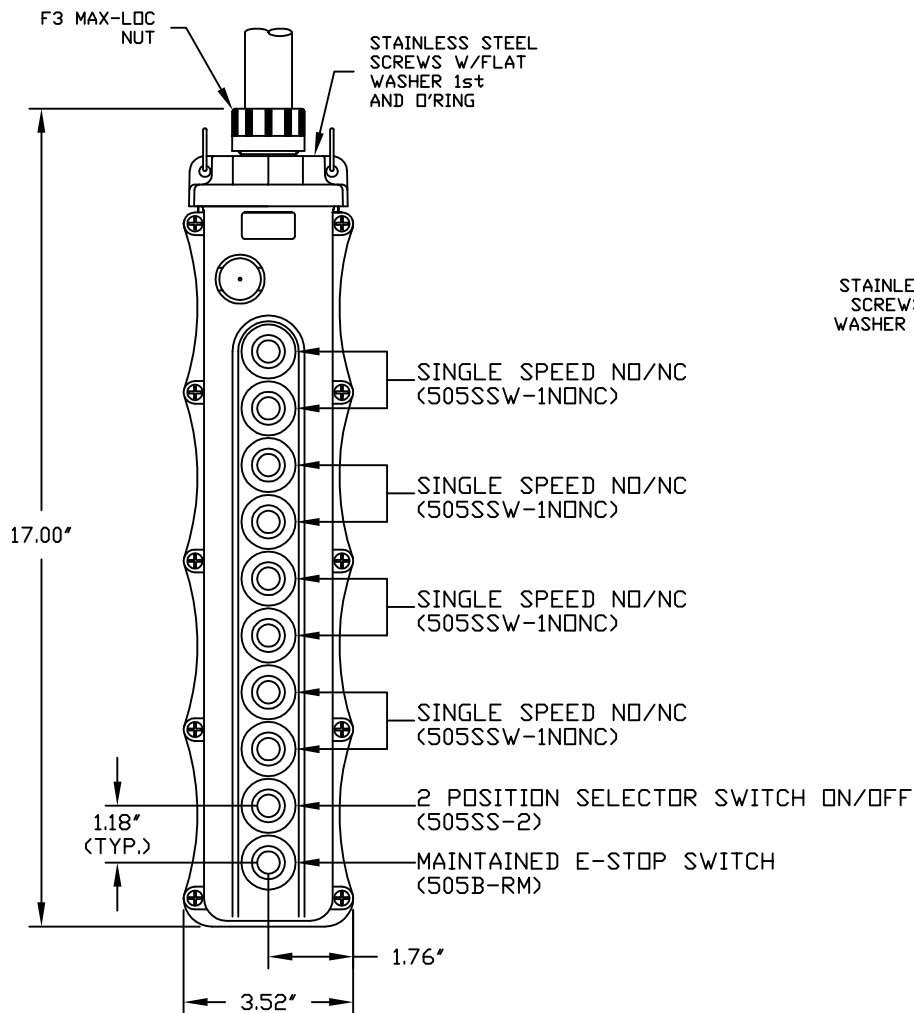

NOTES:
 1. INSTALLATION INSTRUCTIONS, BUTTON ID. LABELS. ARE PACK WITH THE PART.
 2. ALL BUTTONS ARE HIGH AMBIENT, CHEMICALLY RESISTANT MATERIAL - COLOR BLACK

RELEASE DRAWING
 EC NO: WNA2009-0623
 DRWN: TVICKERS 3/26/09
 CHKD: HK 2008/12/16
 APPR: DITLUS 2009/04/01
 REV DESCRIPTION

QUALITY SYMBOLS
 ▽=0
 ∇=0

GENERAL TOLERANCES (UNLESS SPECIFIED)		
	mm	INCH
4 PLACES	±----	±----
3 PLACES	±----	±.020
2 PLACES	±----	±.010
1 PLACE	±----	±.005
ANGULAR ±5°		
DRAFT WHERE APPLICABLE MUST REMAIN WITHIN DIMENSIONS		

DIMENSION STYLE	
INCH	
DRAWN BY	DATE
TV	2009/03/26
CHECKED BY	DATE
HK	2009/03/26
APPROVED BY	DATE
DT	2009/03/26
MATERIAL NO.	1301260309
SIZE	A

SCALE	DESIGN UNITS	THIRD ANGLE PROJECTION
NTS	INCH	☉
TITLE		
5060 W/(4) AB2 L2 & SM E-STOP		
MOLEX INCORPORATED		
DOCUMENT NO.	SHEET NO.	
SD-130126-025	1 OF 1	
THIS DRAWING CONTAINS INFORMATION THAT IS PROPRIETARY TO MOLEX INCORPORATED AND SHOULD NOT BE USED WITHOUT WRITTEN PERMISSION		

6

5

4

3

2

1