

Introduction

This user guide introduces the Atmel® SAMA5D4 Xplained Ultra evaluation kit (SAMA5D4-XULT) and describes the development and debugging capabilities for applications running on the Atmel | SMART SAMA5D4 ARM® Cortex®-A5-based embedded microprocessor unit (eMPU).

Scope

This guide provides details on the SAMA5D4-XULT. It is made up of four main sections:

- [Section 1](#). describes the evaluation kit content and its main features.
- [Section 2](#). provides instructions to power up the SAMA5D4-XULT board.
- [Section 3](#). provides an overview of the SAMA5D4-XULT board.
- [Section 4](#). describes the SAMA5D4-XULT board components.

Kit Contents

The SAMA5D4-XULT includes:

- Board
 - One SAMA5D4-XULT board
- Cables
 - One Micro-AB type USB cable
- Welcome letter

Table of Contents

Introduction	1
Scope	1
Kit Contents	2
Table of Contents	3
1. Evaluation Kit Specifications	4
1.1 Electrostatic Warning	4
1.2 Power Supply Warning	4
2. Power Source	5
2.1 Power up the Board.	5
2.2 Sample Code and Technical Support	5
3. Hardware Overview	6
3.1 Introduction	6
3.2 Equipment List.	6
3.3 Board Features	6
4. Board Components	7
4.1 Board Overview.	7
4.2 Function Blocks.	9
4.3 PIO Usage and Interface Connectors	41
4.4 SAMA5D4-XULT Board Schematics	57
5. Revision History	72

1. Evaluation Kit Specifications

Table 1-1. Evaluation Kit Specifications

Characteristic		Specifications
Board		SAMA5D4-XULT
Board supply voltage		USB powered 5VDC from optional jack connector or from “Arduino shield”
Temperature	Operating	0°C to +70°C
	Storage	-40°C to +85°C
Relative Humidity		0 to 90% (non-condensing)
Dimensions: Main board		135 × 88 × 20 mm
RoHS status		Compliant
Board Identification		SAMA5D4-XULT

1.1 Electrostatic Warning



ESD-Sensitive Electronic Equipment!

The evaluation kit is shipped in a protective anti-static package. The board system must not be subject to high electrostatic potentials.



We strongly recommend using a grounding strap or similar ESD protective device when handling the board in hostile ESD environments (offices with synthetic carpet, for example). Avoid touching the component pins or any other metallic element on the board.

1.2 Power Supply Warning



Hardware Power Supply Limitation

Using a power adapter greater than 5Vcc (e.g., the 12Vcc power adapters from other kits such as Arduino kits) may damage the board.



Hardware Power Budget

Using the USB as the main power source (max. 500 mA) is acceptable only with the use of the on-board peripherals and low-power LCD extension.

When external peripheral or add-on boards need to be powered, we recommend the use of an external power adapter connected to the J4 DC jack (can provide up to 1.2A on the 3.3V node).

2. Power Source

Several options are available to power up the SAMA5D4-XULT board.

The board can be:

- USB-powered through the USB Micro-AB connector (J11 - default configuration).
- Powered through an external AC-to-DC adapter connected via a 2.1 mm center-positive plug into the optional power jack of the board (J4). The recommended output voltage range of the power adapter is 5V at 2A.
- Powered through the Arduino shield.
- Powered through the USB Micro-AB connector on the Atmel Embedded Debugger (EDBG) interface (J20).



Unlike Arduino Uno boards, the SAMA5D4-XULT board runs at 3.3V. The maximum voltage that the I/O pins can tolerate is 3.3V. Providing higher voltages (e.g., 5V) to an I/O pin could damage the board.

2.1 Power up the Board

Unpack the board, taking care to avoid electrostatic discharge. Connect the USB Micro-AB cable to the connector (J11). Then connect the other end of the cable to a free USB port of your PC.

Table 2-1. Electrical Characteristics

Electrical Parameter	Values
Input voltage	5 VCC
Maximum Input voltage (limits)	6 VCC
Max DC 3v3 current available	1.2A
I/O Voltage	3.3V only

2.2 Sample Code and Technical Support

After boot up, you can run some sample code or your own application on the development kit. You can download sample code and get technical support from the [Atmel website](#).

Linux software and demos can be found on the website [Linux4SAM](#).

3. Hardware Overview

3.1 Introduction

The Atmel SAMA5D4-XULT is a fully-featured evaluation platform for the Atmel SAMA5D4 series ARM-based embedded microprocessor units (eMPU). It allows users to extensively evaluate, prototype and create application-specific designs.

3.2 Equipment List

The SAMA5D4-XULT board is based on the integration of an ARM Cortex-A5-based microprocessor with external memory, one Ethernet physical layer transceiver, two SD/MMC interfaces, two host USB ports and one device USB port, one 24-bit RGB LCD and HDMI interface and debug interfaces.

Seven headers, compatible with Arduino R3 (Uno, Due) and two Xplained headers are available for various shield connections.

3.3 Board Features

Table 3-1. Board Specifications

Characteristics	Specifications
Dimensions (L x W x H)	135 x 88 x 20 mm
Processor	SAMA5D44 (361-ball BGA package), 16x16 mm body, pitch 0.8 mm
Oscillators	MPU, EDBG: 12 MHz quartz RTC: 32.768 kHz PHY: 25 MHz
Main Memory	2 x DDR2 2 Gb 16 Meg x 16 x 8 banks (total 4 Gbit = 512 MB) 1 x SLC NAND Flash 4 Gb 8-bit data (total 4 Gbit = 512 MB)
Accessory memories	One optional Serial EEPROM SPI One EEPROM with Mac Address and Serial Number
SD/MMC	One 4-bit SD card connector One 4-bit Micro-SD card connector
USB	Two USB Hosts with power switch One Micro-AB USB device
Display	One LCD interface connector, LCD TFT Controller with overlay, alpha-blending, rotation, scaling and color space conversion One HDMI interface and connector
Ethernet	One Ethernet PHY (RMII 10/100MHz)
Debug port	One JTAG interface connector One EDBG interface One serial DBGU interface (3v3 level)
Expansion connector	Arduino R3 compatible set of connectors XPRO set of connectors
Board supply voltage	5V from USB, power jack, and Arduino shield On-board power regulation by PMIC
Battery	On-board battery socket
User interface	Reset, Wake-up and free user push button One red user/power LED One blue user LED

4. Board Components

4.1 Board Overview

The fully-featured SAMA5D4-XULT board integrates multiple peripherals and interface connectors, as shown in Figure 4-1.

Figure 4-1. SAMA5D4-XULT Board Overview

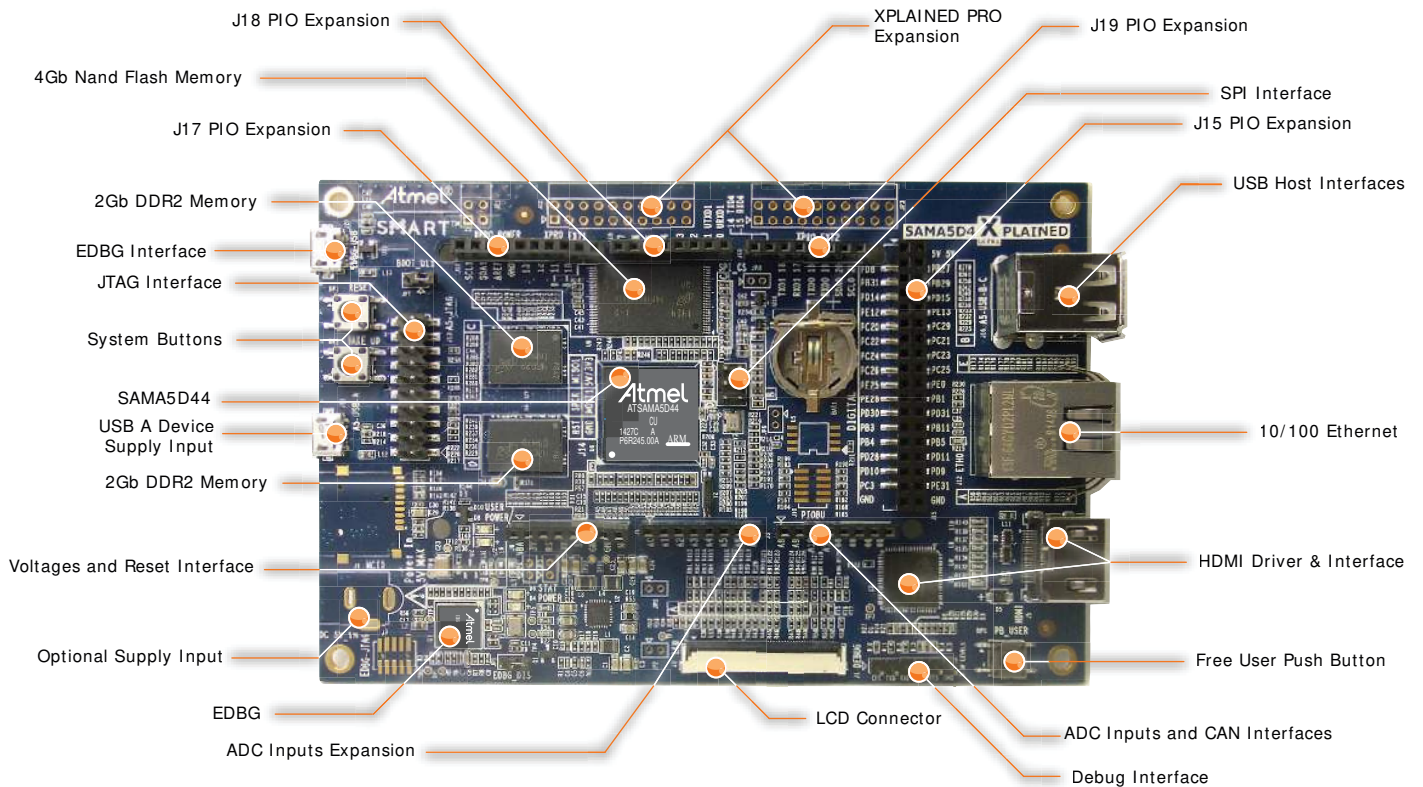

Table 4-1 describes the interface connectors on the SAMA5D4-XULT.

Table 4-1. SAMA5D4-XULT Board Interface Connectors

Connector	Interfaces to
J4	Main power supply
J11	USB A Device. Supports USB device using a type Micro-AB connector
J16	USB Host B and C. Supports USB host using a stacked type A connector
J1	Serial DBGU (3.3V level)
J13	JTAG, 20 pin IDC connector
J20	EDBG USB connector
J9	Micro-SD connector
J24	SD/MMC connector
J12	Ethernet ETH0
J2	Expansion connector with all LCD controller signals for display module connection (QTouch [®] , TFT LCD display with touchscreen and backlight)
J5	HDMI connector type A
BAT1	CR1225 Battery holder
J6, J7, J8, J14, J15, J17, J18, J19	Expansion connectors with Arduino R3 compatible PIO signals
J21, J22, J23	Expansion connectors Xplained
J3	JTAG EDBG (not populated)
J10	PIOBU extension (not populated)

4.2 Function Blocks

4.2.1 Processor

The Atmel® | SMART SAMA5D4 Series is a high-performance, power-efficient ARM® Cortex®-A5 processor MPU capable of running up to 600 MHz. It integrates the ARM NEON™ SIMD engine for accelerated signal processing, multimedia and graphics as well as a 128 KB L2-Cache for high system performance. The device features the ARM TrustZone® enabling a strong security perimeter for critical software, as well as several hardware security features. The device also features advanced user interface and connectivity peripherals.

The SAMA5D4 devices have three software-selectable low-power modes: Idle, Ultra Low-power, and Backup. In Idle mode, the processor is stopped while all other functions can be kept running at normal operating bus frequency. In Ultra Low-power mode, the processor is stopped while all other functions can be kept running at minimum operating bus frequency. In Backup mode, only the real-time clock, real-time timer, backup SRAM, backup registers, and wake-up logic are running.

The SAMA5D4 features an internal multi-layer bus architecture associated with 32 DMA channels to sustain the high bandwidth required by the processor and the high-speed peripherals. The device supports DDR2/LPDDR/LPDDR2 and SLC/MLC NAND Flash memory with 24-bit ECC.

The comprehensive peripheral set includes a 720p hardware video decoder, an LCD controller with overlays for hardware-accelerated image composition, a resistive touch screen function, and a CMOS sensor interface. Connectivity peripherals include a dual 10/100 Ethernet MAC with IEEE1588, three HS USB ports, UARTs, SPIs and I2Cs.

Security features includes an "on-the-fly" encryption-decryption process from the external DDR memory, tamper detection pins, secure storage of critical data, an integrity check monitor (ICM) to detect modification of the memory contents and a secure boot. The product also includes a dedicated coprocessor for public key cryptography such as RSA and elliptic curves algorithms (ECC), as well as AES, 3DES, SHA function and TRNG. These features permit to protect the system against counterfeiting, to safeguard sensitive data, authenticate safe program or secure external data transfers.

The SAMA5D4 series is optimized for control panel/HMI applications needing video playback and applications that require high levels of connectivity in the industrial and consumer market. Its security features make the SAMA5D4 well suited for secure gateways or for the IoT.

4.2.2 Power Supply Topology and Power Distribution

4.2.2.1 Power Lines

Refer to the Power Supplies and Power Supply Connections tables in the SAMA5D4 datasheet.

4.2.2.2 Power-up and Power-down Considerations

Power-up and power-down considerations are described in section "Power Considerations" of the SAMA5D4 Series datasheet.

4.2.2.3 SAMA5D44 Power Supplies Summary

Table 4-2. SAMA5D44 Power Supplies

Name	Voltage Range, Nominal	Associated Ground	Powers
VDDCORE	1.62–1.98V, 1.8V	GNDCORE	Regulator that generates core power supply on VDDCORE 10 μ F decoupling capacitor is to be connected to VDDCORE MUST BE ESTABLISHED AFTER VDDIOP OR AT THE SAME TIME
VCCCORE	1.1–1.32V, 1.2V	GNDCORE	Core
VDDIODDR	1.70–1.90V, 1.8V	GNDIODDR	DDR2 Interface I/O lines
	1.14–1.30V, 1.2V		LP-DDR2 Interface I/O lines
VDDIOM	1.65–1.95V, 1.8V 3.0–3.6V, 3.3V	GNDIOM	NAND and HSMC Interface I/O lines
VDDIOP ⁽¹⁾	3.0–3.6V, 3.3V	GNDIOP	Peripherals I/O lines MUST BE ESTABLISHED PRIOR TO VDDCORE
VDDBU	1.88–2.12V, 2V	GNDBU	Slow Clock oscillator, the internal 64 kHz RC and a part of the System Controller MUST BE ESTABLISHED FIRST
VDDUTMIC	1.1–1.32V, 1.2V	GNDUTMI	USB device and host UTMI+ core and the UTMI PLL MUST be connected to VCCCORE
VDDUTMII	3.0–3.6V, 3.3V	GNDUTMI	USB device and host UTMI+ interface
VDDPLLA	1.1–1.32V, 1.2V	GNDPLL	PLLA cell MUST be connected to VCCCORE
VDDOSC	3.0–3.6V	GNDOSC	Main Oscillator cell
VDDANA ⁽¹⁾	3.0–3.6V, 3.3V	GNDANA	Analog parts MUST be connected to VDDIOP with filtering
VDDFUSE	2.25–2.75V, 2.5V	GNDFUSE	Fuse box for programming VDDFUSE must be 2.5V or 0V and must not be left floating

Notes: 1. Both VDDIOP and VDDANA must rise at the same time due to internal constraints.

4.2.2.4 ACT8865 Power Management IC

The ACT8865 is a complete, cost-effective and highly-efficient ActivePMU™ power management solution, optimized to provide a single-chip power solution and voltage sequencing for Atmel SAMA5D3/SAMA5D4 and SAM9 series MPUs. It also meets the control requirements of these devices.

The ACT8865 features three step-down DC/DC converters and four low-noise, low-dropout linear regulators.



There is a known error on the ACT8865 I²C implementation. The port must be shut off after configuration or problems may occur with devices using the same I²C channel, e.g., TM43xx LCD display.

Refer to the ACT8865 datasheet at www.active-semi.com for more details.

Figure 4-2. Board Power Management

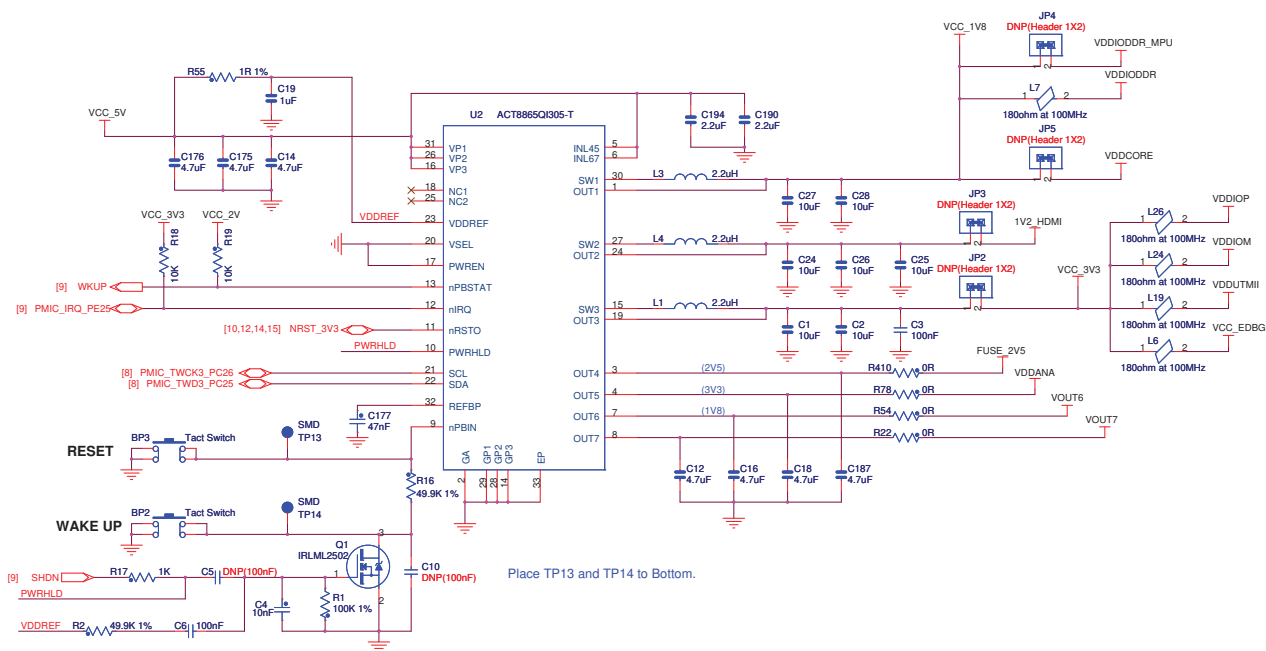

Supply Group Configuration

The ACT8865 provides:

- All power supplies required by the SAMA5D44 device:
 - 1.8V VDDCORE
 - 1.8V VDDIOPDDR
 - 2.0V VDDBU
 - 3.3V VDDIOP, VDDIOM, VDDANA, VDDUTMII
 - 2.5V VDDFUSE
- Power supplies to external chips on the main board:
 - 1.2V HDMI
 - 3.3V Ethernet PHY, HDMI, EDBG

4.2.2.5 Power Options

There are several power options for the SAMA5D4-XULT board.

The power sources are selected by a set of 0R resistors. The USB-powered operation is the default configuration. It comes from the USB device port connected to a PC or a 5V DC supply. The USB supply is sufficient to power the board in most applications. It is important to note that when the USB supply is used, the USB Host ports do not function. If USB Host ports are required for the application, it is recommended that a DC supply be used.

Figure 4-3 provides the schematics of power options.

Figure 4-3. Input Powering Scheme Option

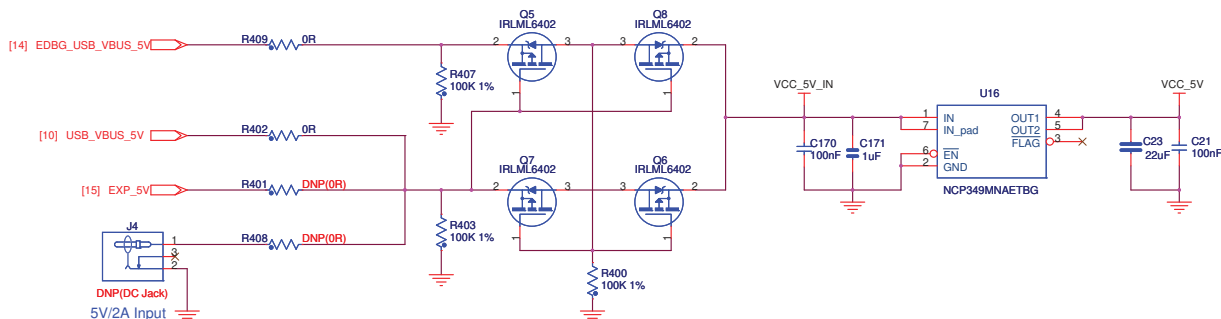

Note: USB-powered operation eliminates additional wires and batteries. It is the preferred mode of operation for any project that requires only a 5V source at up to 500 mA.

4.2.2.6 Wall Supply Source

A wall supply can be used to provide power to the board. A regulated 5V DC supply of at least 2A is required. If USB ports and expansion headers are used, a rating of 3A is preferred. A 2.1 mm plug with a center-hot configuration is required.

If the USB host ports or expansion board Arduino shields are used, additional current is necessary.

If the DC load required is greater than 500 mA per port, a higher current supply must be used.

4.2.2.7 Backup Power Supply

The SAMA5D4-XULT board requires a battery (3V lithium battery type CR1225 or equivalent) in order to permanently power the backup part of the SAMA5D4 device (refer to SAMA5D4 Series data sheet).

To avoid losing data and saved registers, the board must be powered on when replacing the battery.

Figure 4-4. VBAT Powering Scheme Option

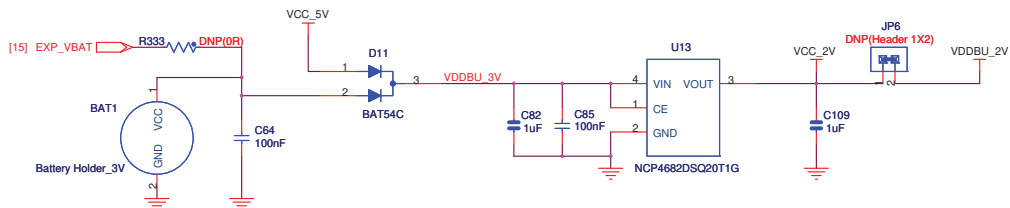

4.2.2.8 Power Supply Control

In the ACT8865, three DCDCs (1.8V, 1.2V, 3.3V) and two LDO outputs are available.

All ACT8865 outputs can be controlled by the TWI interface through software.

The three DCDCs outputs can be enabled or disabled by the SAMA5D44 SHDN output:

- SHDN = 0: The DCDCs output is disabled.
- SHDN = 1: The DCDCs output is enabled.

Two push buttons are also available:

- Wakeup push button: When pressed, the ACT8865 power outputs are restarted if the ACT8865 is in shutdown mode.
- Reset push button: When pressed, the ACT8865 transfers the reset signal to NRST_3V3, and then to NRST_2V for the MPU by using a resistor divider.

4.2.3 Reset Circuitry

The reset sources for SAMA5D4-XULT board are:

- Power-on reset from the Power Management Unit (PMIC)
- Push button reset BP3
- External reset from Arduino connectors
- JTAG or EDBG reset from an in-circuit emulator

Figure 4-5. Reset/Wakeup and Shutdown Control

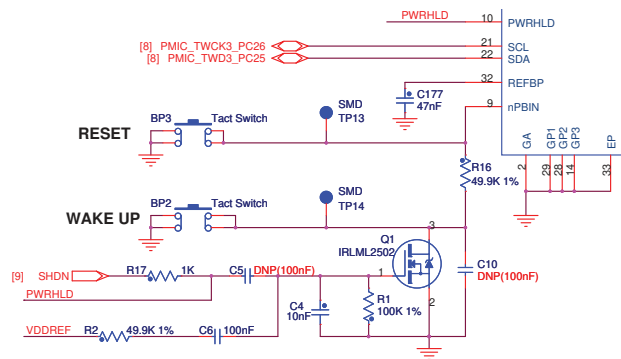

4.2.4 Clock Circuitry

The SAMA5D4-XULT board includes four clock sources:

- Two clocks are alternatives for the SAMA5D44 processor (12 MHz, 32 kHz)
- One crystal oscillator used for the Ethernet RMII chip (25 MHz)
- One crystal oscillator used for the EDBG (12 MHz)

Figure 4-6. Clock Circuitry

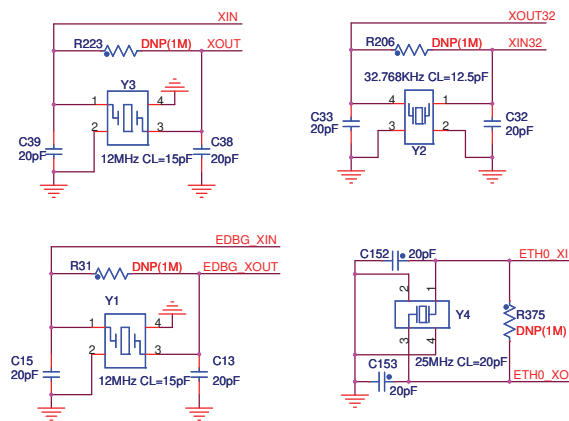

4.2.5 Memory

4.2.5.1 Memory Organization

The SAMA5D4 features a DDR/SDR memory interface and an External Bus Interface (EBI) to permit interfacing to a wide range of external memories and to almost any kind of parallel peripheral.

This section describes the memory devices that equip the SAMA5D4-XULT board.

4.2.5.2 DDR2/SDRAM

- Two DDR2/SDRAM (MT47H128M16 - 2 Gb - 16 Meg x 16 x 8 banks) are used as main system memory. The board provides 4 Gb on-board, soldered DDR2 (double data rate) SDRAM. The memory bus is 32 bits wide and operates with a frequency of up to 176 MHz.

Figure 4-7. DDR2

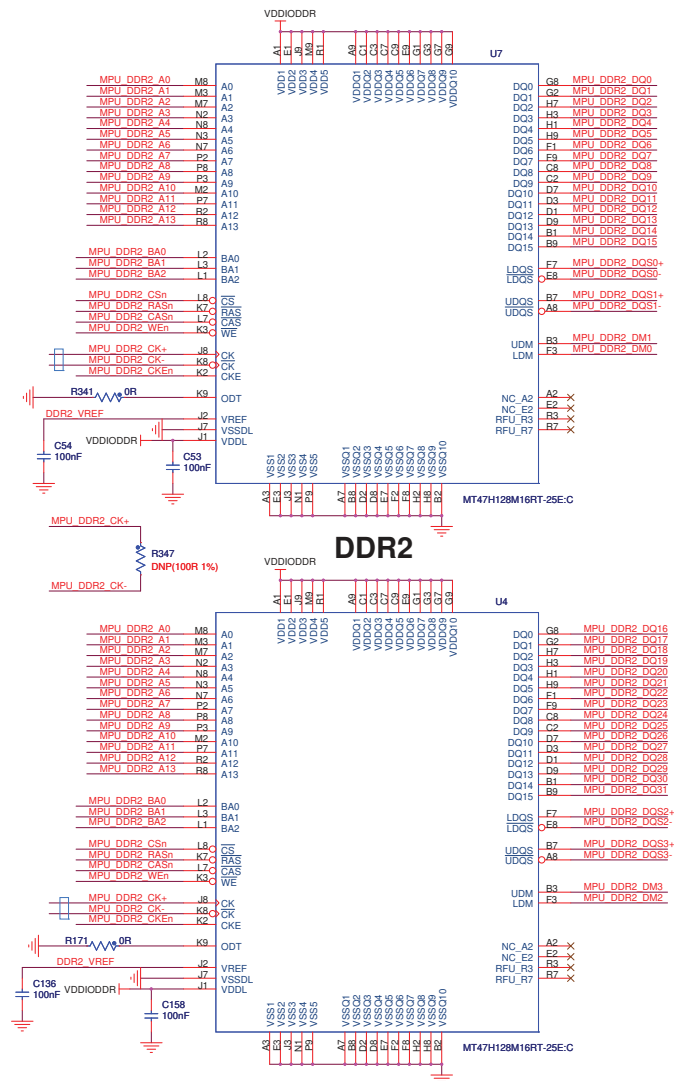

4.2.5.3 DDR_CALP and DDR_CALN Analog Inputs

Two specific analog inputs, DDR_CALP and DDR_CALN, are used to calibrate all DDR I/Os.

Figure 4-8. DDR_CALP and DDR_CALN Analog Inputs

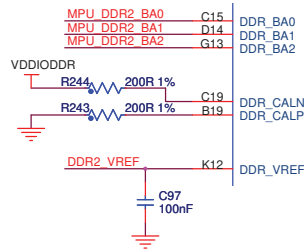

Table 4-3. DDR_CALN and DDR_CALP

Memory Type	CALP Pull-down	CALN Pull-up
DDR2	200 ohm	200 ohm
LPDDR2	240 ohm	240 ohm

4.2.5.4 NAND Flash

One 512 MB NAND Flash is connected to the processor.

Figure 4-9. NAND Flash

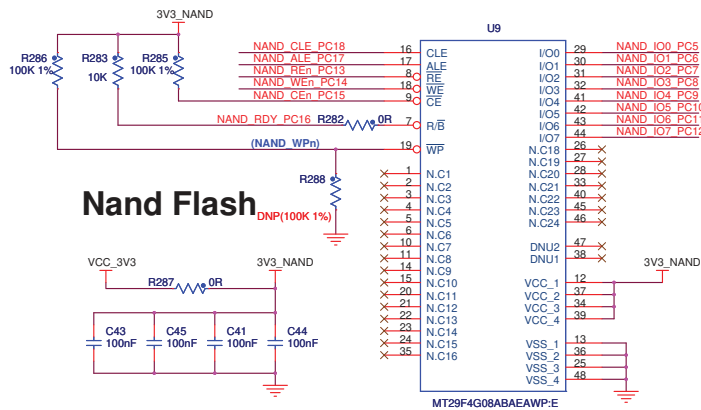

4.2.5.5 CS Disable

The SAMA5D44 device boots according to the following sequence:

1. D CARD connected on MCI1
2. Optional Dataflash connected on NPCS0 SPI0
3. 8-bit NAND Flash connected to D0–D7

In this sequence, the first device found with bootable contents is selected as the boot source. The others are disregarded.

On-board jumpers (JP7, JP8) control the selection (CS#) of the on-board bootable memory components (NAND Flash and Serial DataFlash) using a non-inverting 3-state buffer.

Figure 4-10. CS Disable

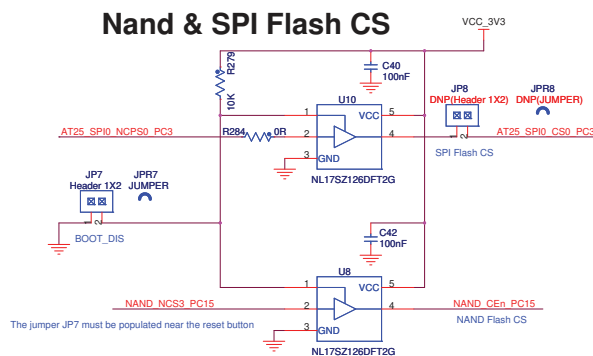

The rule of operation is:

- JP7 = OFF (default) → enable normal boot from NAND Flash (or serial DataFlash if mounted)
- JP7 = ON → booting from optional serial DataFlash or NAND Flash is disabled

JP8 (optional) also controls the serial DataFlash if mounted.

Refer to the SAMA5D4 Series datasheet for more information on standard boot strategies and sequencing.

4.2.6 Additional Memories

4.2.6.1 Serial Data Flash (optional)

The SAMA5D44 provides two high-speed Serial Peripheral Interface (SPI) controllers. One port is used to interface with the optional on-board serial DataFlash.

The four main signals used in the SPI are Clock, Data In, Data Out, and Chip Select. The SPI is a serial interface similar to the I²C bus interface but with three main differences:

- It operates at a higher speed.
- Transmit and receive data lines are separate.
- Device access is chip select-based instead of address-based.

Figure 4-11. Optional Serial DataFlash

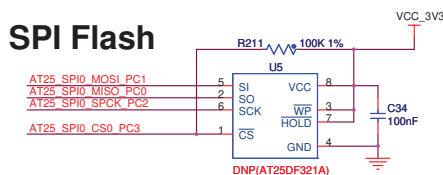

4.2.6.2 Serial EEPROM with Unique MAC Address

The SAMA5D4-XULT board embeds one Atmel AT24MAC402/602 EEPROM using a TWI0 interface.

The AT24MAC402/602 provides 2048 bits of Serial Electrically-Erasable Programmable Read-Only Memory (EEPROM) organized as 256 words of eight bits each and is accessed via an I²C-compatible (2-wire) serial interface. In addition, the AT24MAC402/602 incorporates an easy and inexpensive method to obtain a globally unique MAC or EUI address (EUI-48 or EUI-64).

The EUI-48/64 addresses can be assigned as the actual physical address of a system hardware device or node, or it can be assigned to a software instance. These addresses are factory-programmed by Atmel and permanently write-protected in an extended memory block located outside of the standard 2-Kbit memory array.

In addition, the AT24MAC402/602 provides the value-added feature of a factory-programmed, guaranteed unique 128-bit serial number located in the extended memory block (same area as the EUI address values).

The EEPROM device is used as a “soft label” to store board information such as chip type, manufacture name and production date, using the last two 16-byte blocks in memory.



WARNING

The information contained in these blocks should not be modified.

Figure 4-12. EEPROM

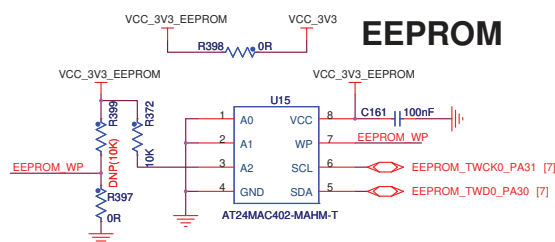

4.2.7 High-Speed Multimedia Card Interface (HSMCI)

4.2.7.1 Multimedia Card Interface (MCI)

The SAMA5D4-XULT board has two high-speed Multimedia Card interfaces (MCIs) that support the multimedia card (MMC) Specification V4.3, the SD Memory Card Specification V2.0 and the SDIO V1.1 specification:

- **MCI0 interface** based on a 7-pin interface (clock, command, 4-bit data, power lines).
- **MCI1 Interface** based on a 7-pin interface (clock, command, 4-bit data, power lines).

4.2.7.2 HSMCI Card Connector

A standard MMC/SD card (push and click type) connector, connected to MCI1, is mounted on the top side of the board. It features a push-lock / push-eject mechanism and a card detection switch.

A micro SD card (push and click type) connector, connected to MCI0, is mountable as an option on the bottom side of the board.

Figure 4-13. HSMCI0 & HSMCI1

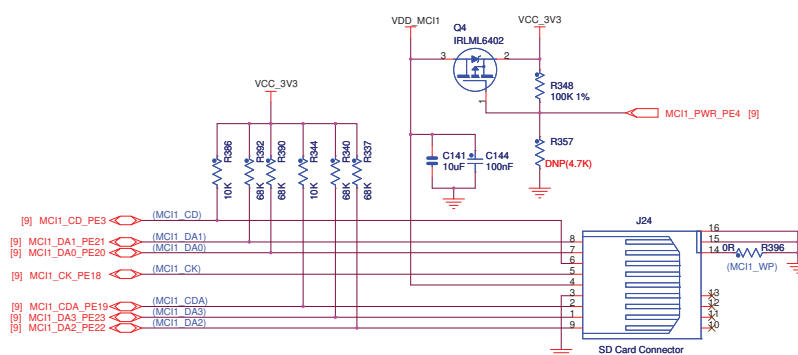

SD/MMCplus CARD INTERFACE - MCI1

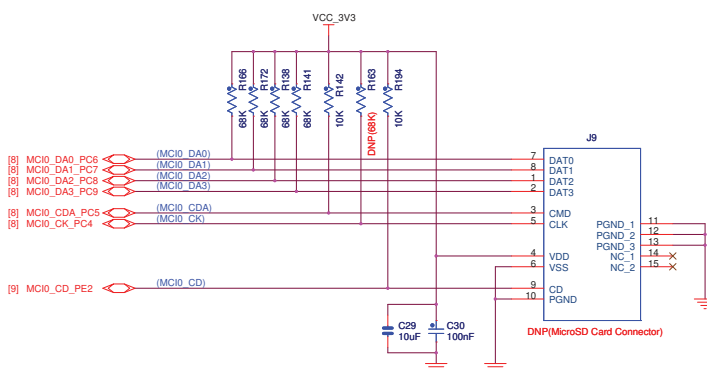

Micro SD CARD INTERFACE - MCI0

4.2.8 Communication Interfaces

The SAMA5D4-XULT board is equipped with EMAC and USB Host/Device communication interfaces.

4.2.8.1 Ethernet 10/100 (EMAC) Port

The SAMA5D4-XULT board contains a MICREL PHY device (KSZ8081) operating at 10/100 Mb/s. The board supports RMII interface modes. The Ethernet interface consists of two pairs of low-voltage differential pair signals designated from GRX± and GTX± plus control signals for link activity indicators. These signals can be used to connect to a 10/100 Base-T RJ45 connector integrated on SAMA5D4-XULT board.

Additionally, for monitoring and control purposes, LED functionality is carried on the RJ45 connectors to indicate activity, link, and speed status information.

For more information about the Ethernet controller device, refer to the MICREL KSZ8081RN controller manufacturer's datasheet.

Figure 4-14. Ethernet

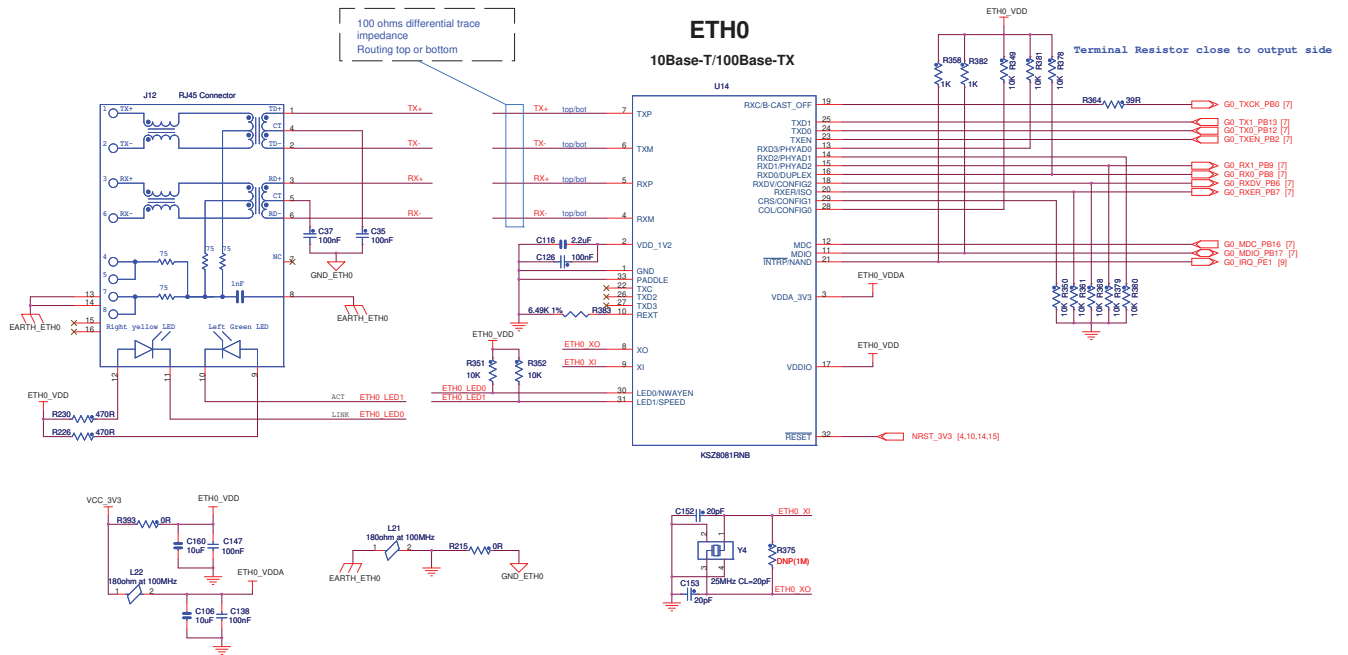

4.2.8.2 USB Host/Device A, B & C

The SAMA5D4-XULT board features three USB communication ports:

- USB Host B/C High- and Full-speed Interface
 - Two USB host stacked type A connectors.
- USB Host/Device A Interface
 - One USB device standard micro-AB connector. This port has a VBUS detection function made through the resistor ladder R218 and R214.

Figure 4-15. USB Host & Device Interface

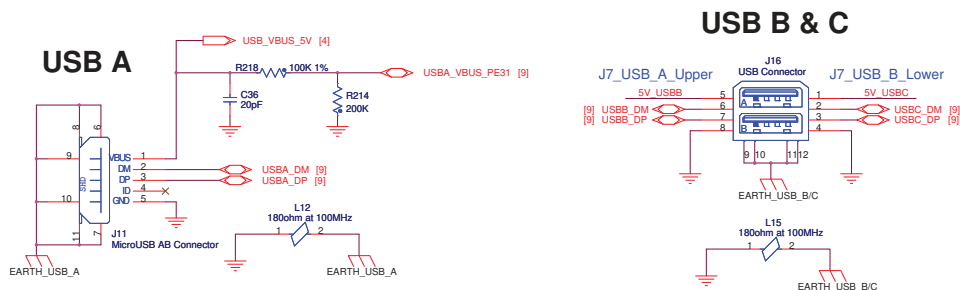

The two USB Host ports are equipped with 500 mA high-side power switch for self-powered and bus-powered applications.

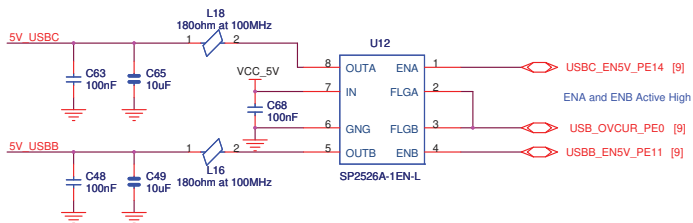

4.2.9 LCD TFT Interface

4.2.9.1 LCD

The SAMA5D4 provides 24 bits of data and control signals to the LCD interface. Other signals are used to control the LCD and are available on connector J2: TWI, SPI, 2 GPIOs for interrupt, 1-Wire and power supply lines.

4.2.9.2 LCD Expansion Header

J2 is a 1.27mm pitch 50-pin header; it gives access to the LCD signals.

Figure 4-16. LCD Expansion Header Interface

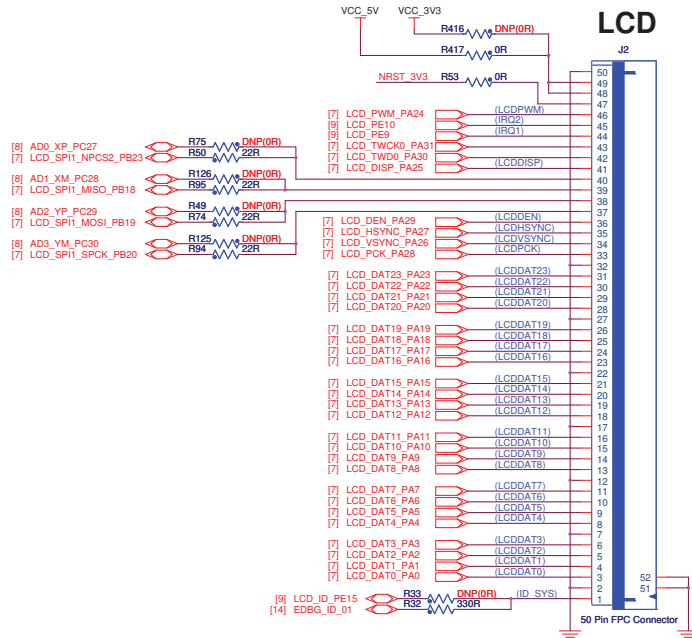

4.2.9.3 LCD Power

In order to operate correctly out of the processor with various LCD modules, two voltage lines are available: 3.3V and 5 VCC (default), both selected by 0R resistors R416 and R417.

Figure 4-17. LCD Power

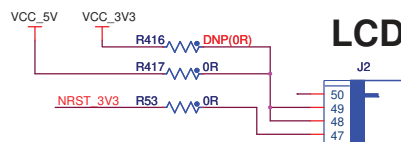

4.2.11 Indicators

There are two LEDs on the SAMA5D4-XULT board that can be controlled by the user:

- The red LED provides an indication that power is supplied to the board and is controlled via software.
- The blue LED is controlled via GPIO pins.

Figure 4-19. LED Indicators

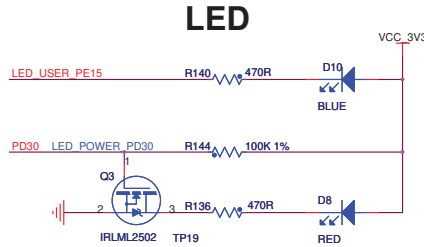

4.2.12 Push Button Switches

The SAMA5D4-XULT features three push buttons:

- One board Reset button (BP3). When pressed and released, it causes a power-on reset of the board.
- One Wakeup push button to exit the processor from low-power mode (BP2).
- One User momentary push button (BP1).

Figure 4-20. Push Buttons

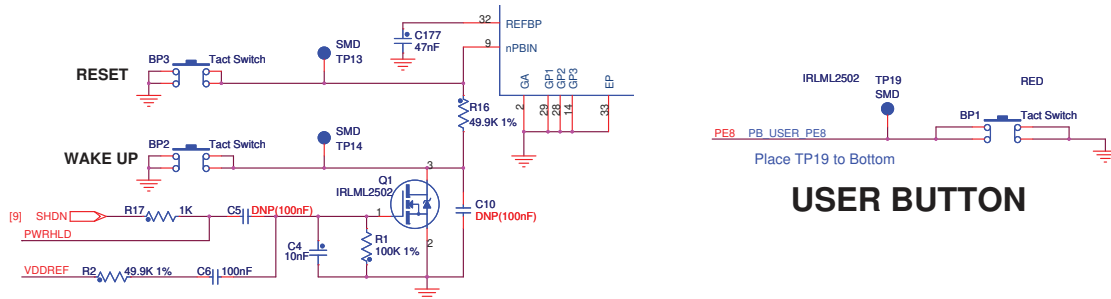

4.2.13 Debug Interfaces

The SAMA5D4-XULT board includes a JTAG, a Debug serial COM port and an EDBG interface port, to provide debug level access to the SAMA5D4.

4.2.13.1 Debug JTAG

A 2x10-pin JTAG header is provided on the SAMA5D4-XULT board to facilitate the software development and debugging by using various JTAG emulators. The interface signals have a voltage level of 3.3V.

Figure 4-21. JTAG Interface

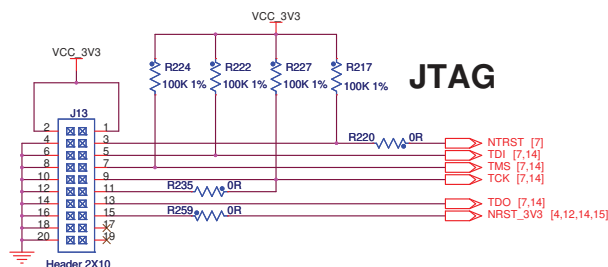

4.2.13.2 DBGU

The SAMA5D4-XULT board has a dedicated serial port for debugging, which is accessible through the 6-pin male header J1. Various interfaces can be used as USB/Serial DBGU port bridge, such as FTDI TTL-232R USB to TTL serial cable or basic breakout board for the RS232/USB converter.

Figure 4-22. DBGU Interface

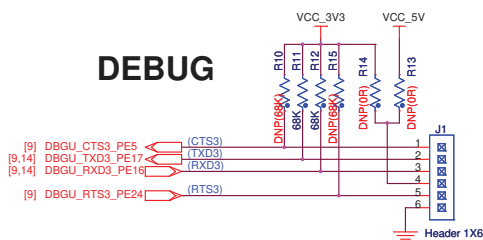

R13 and R14 are optional (not implemented) resistors that can be used for power selection. Power can be delivered either by the SAMA5D4-XULT board or by the debug interface tool. To avoid malfunction between the debug interface (e.g., FTDI) and the on-board power system, ensure that the voltage level selected corresponds to application requirements.

4.2.14 Embedded Debugger (EDBG) Interface

The Atmel Embedded Debugger (EDBG) ⁽¹⁾ is an intuitive plug-and-play solution which adds full programming and debugging support to embedded hardware kits containing Atmel microcontrollers. It enables seamless integration between the target hardware and the Atmel Studio front end.

In addition to the Virtual COM port which provides a UART bridge to the target device, the EDBG provides a Data Gateway Interface, through which the target device and host PC can communicate, facilitating high-level application debugging, monitoring, graphing and logging of system information in real-time.

The EDBG is based on the Atmel UC3A4 high-performance low-power 32-bit AVR microcontroller running at up to 60 MHz. The device includes an on-chip USB 2.0 high-speed hardware module with dedicated DMA channels, making it ideal for data communications.

By default, the EDBG is in Reset state and not usable. To use the EDBG interface, remove the jumper JP1. To avoid any conflict with the debug signals, do not use the JTAG and EDBG at the same time.

Figure 4-23. EDBG Interface

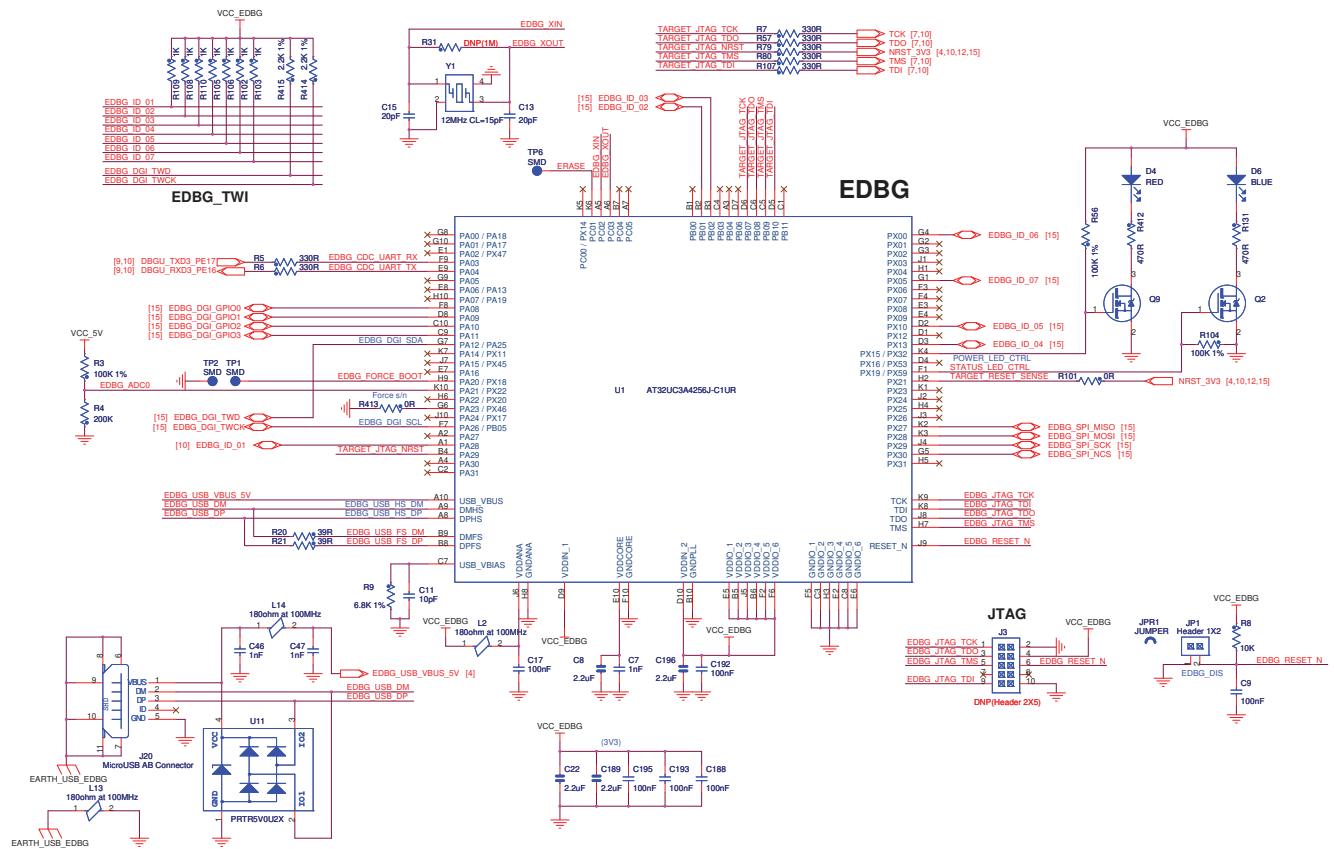

1. Device and Ordering Information—The EDBG is a factory-programmed AT32UC3A4256J-C1UR standard microcontroller with ordering code AT32UC3A4256HHB-C1UR. For further information please contact edbg@atmel.com.

4.2.15 Expansion Ports

4.2.15.1 Arduino

Five 8-pin, one 6-pin, one 10-pin and one 36-pin headers (J6, J7, J8, J14, J15, J17, J18, J19) are provided on the SAMA5D4-XULT board to enable the PIO connection of various expansion cards. These headers' physical and electrical implementation match the Arduino R3 extension ("shields") scheme.

Due to multiplexing, different signals can be provided on each pin.

Figure 4-24. Expansion Boards Connectors

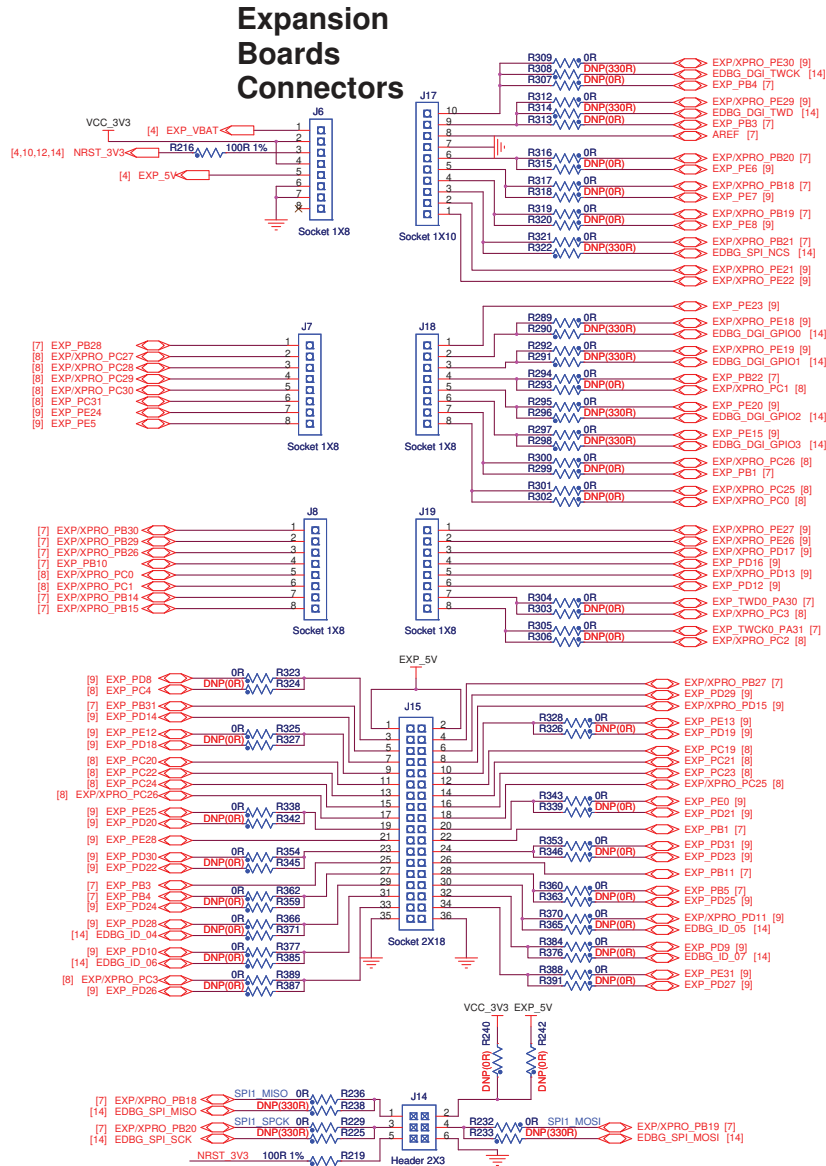

4.2.15.2 Functions Available Through the Arduino Headers

The multiplexing of the SAMA5D44 I/Os (standard parallel I/O and up to three peripheral functions per pin) makes it possible to route alternate signals via Arduino extension headers. To enable these signals, SAMA5D44 PIO multiplexing must be properly configured. For more details, refer to [Section 4.3.15](#) of this document and the section PIO Controller (PIO) in the SAMA5D4 Series datasheet.

In addition, on-board resistors may be unsoldered and moved to an alternate location to enable a different connection.

[Table 4-5](#) to [Table 4-11](#), together with the connector schematics, provide the alternate signals available for use with Arduino connectors.



How to read the tables

For the example [Figure 4-25](#) and [Table 4-4](#) below, the information provided on alternate signals is read as follows:

Pin 3 of Jxx is normally connected to SAMA5D44 PD8 which has PCK0 as an alternate function.

By unsoldering R323 and soldering it on R324 footprint, pin 3 of J15 will be connected to SAMA5D44 PC4 which has SPI0_NPCS1, MCIO_CK and PCK1 as alternate functions.

Figure 4-25. Jxx Connector

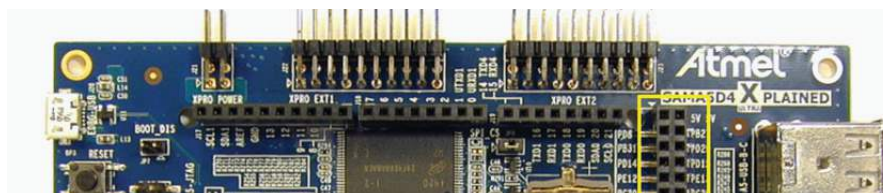

Table 4-4. Jxx Connector Signals

Pin No.	SAMA5D44 PIO Muxing Alternates				On-board Alternates			
	PD8	PCK0	–	–	PC4	SPI0_NPCS1	MCIO_CK	PCK1
3	PD8	PCK0	–	–	PC4	SPI0_NPCS1	MCIO_CK	PCK1

Figure 4-26. J6 Connector

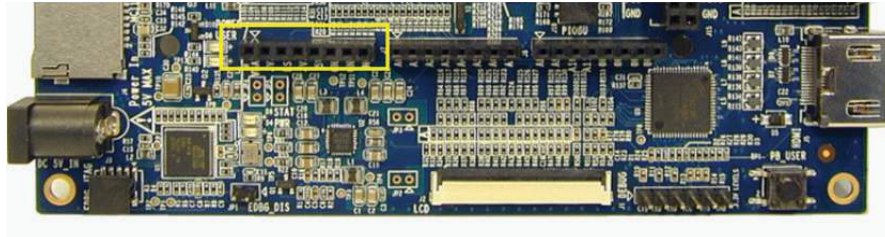
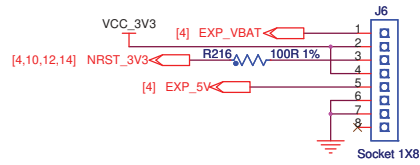

Table 4-5. J6 Connector Signals

Pin No.	Signal				On-board Alternates			
1	EXP_VBAT	–	–	–	–	–	–	–
2	VCC_3V3	–	–	–	–	–	–	–
3	NRST_3V3	–	–	–	–	–	–	–
4	VCC_3V3	–	–	–	–	–	–	–
5	EXP_5V	–	–	–	–	–	–	–
6	GND	–	–	–	–	–	–	–
7	GND	–	–	–	–	–	–	–
8	NC	–	–	–	–	–	–	–

Figure 4-27. J7 Connector

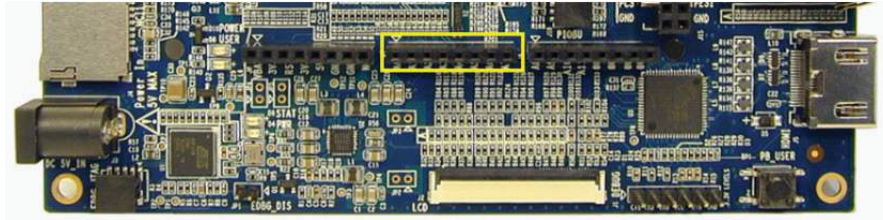
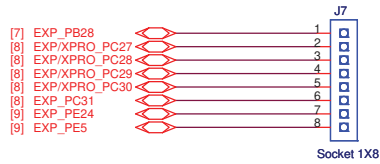

Table 4-6. J7 Connector Signals

Pin No.	SAMA5D44 PIO Muxing Alternates				On-board Alternates			
1	PB28	SPI2_NPCS3	TD0	PWMH1	–	–	–	–
2	PC27	AD0	SPI0_NPCS1	PWML0	–	–	–	–
3	PC28	AD1	SPI0_NPCS2	PWML1	–	–	–	–
4	PC29	AD2	SPI0_NPCS3	PWMF10	–	–	–	–
5	PC30	AD3	–	PWMH0	–	–	–	–
6	PC31	AD4	–	PWMH1	–	–	–	–
7	PE24	NCS0	RTS3	–	–	–	–	–
8	PE5	A5	CTS3	–	–	–	–	–

Figure 4-28. J8 Connector

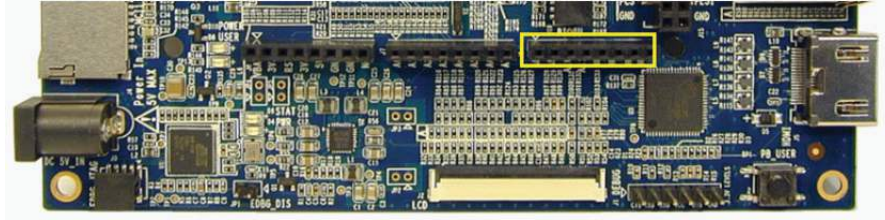
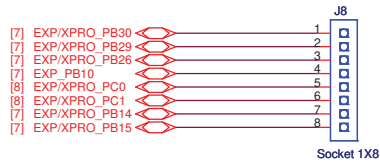

Table 4-7. J8 Connector Signals

Pin No.	SAMA5D44 PIO Muxing Alternates				On-board Alternates
1	PB30	TWCK2	RF0	–	–
2	PB29	TWD2	RD0	PWML1	–
3	PB26	PCK0	RK0	PWMH0	–
4	PB10	G0_RX2	PCK2	PWML1	–
5	PC0	SPI0_MISO	PWMH2	ISI_D8	No DAC available
6	PC1	SPI0_MOSI	PWML2	ISI_D9	No DAC available
7	PB14	G0_TX2	SPI2_NPCS1	PWMH0	No CAN available
8	PB15	G0_TX3	SPI2_NPCS2	PWML0	No CAN available

Figure 4-29. J14 Connector

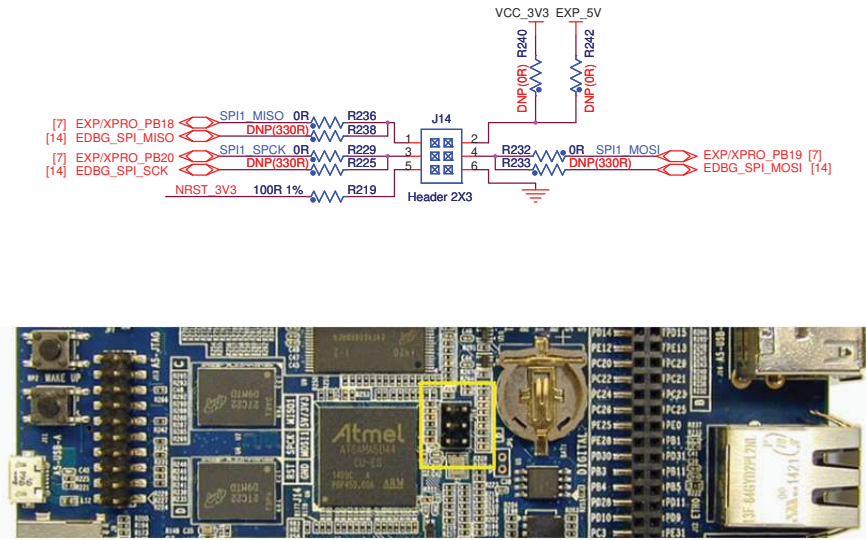

Table 4-8. J14 Connector Signals

Pin No.	SAMA5D4 PIO Muxing Alternates				On-board Alternates				EDBG Alternate
1	PB18	SPI1_MISO	D8	–	–	–	–	–	DGI_SPI
2	5V	–	–	–	–	–	–	–	–
3	PB20	SPI1_SPCK	D10	–	–	–	–	–	DGI_SPI
4	PB19	SPI1_MOSI	D9	–	–	–	–	–	DGI_SPI
5	nRST	–	–	–	–	–	–	–	–
6	GND	–	–	–	–	–	–	–	–

Figure 4-30. J15 Connector

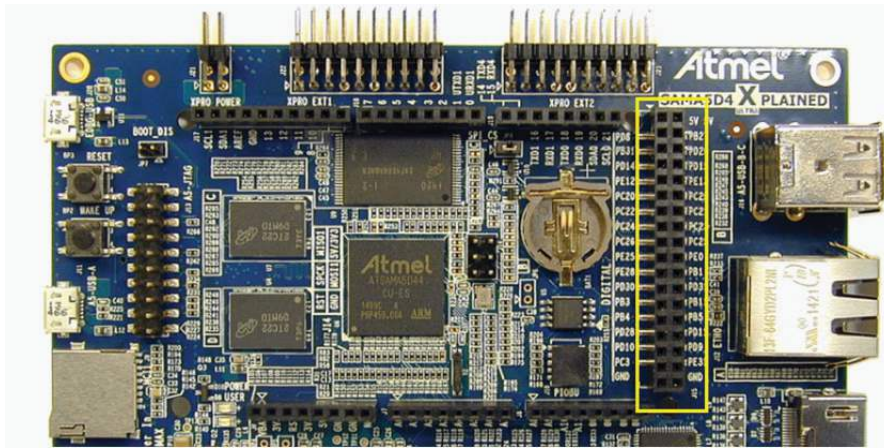
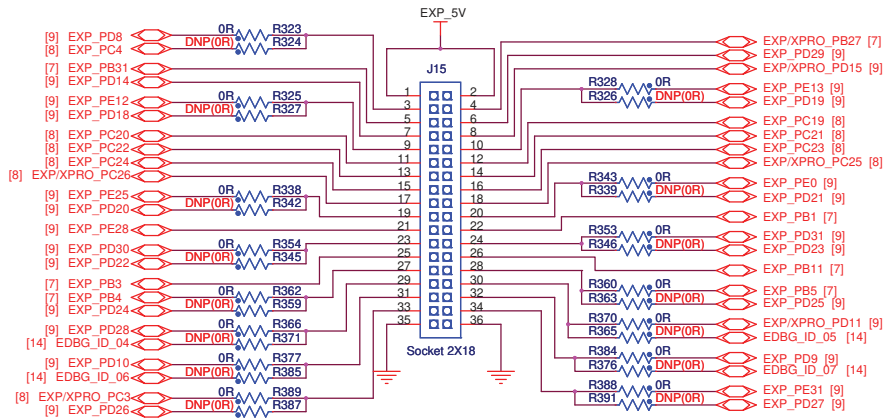

Table 4-9. J15 Connector Signals

Pin No.	SAMA5D44 PIO Muxing Alternates				On-board Alternates			
1	5V	-	-	-	5V	-	-	-
2	5V	-	-	-	5V	-	-	-
3	PD8	PCK0	-	-	PC4	SPI0_NPCS1	MCI0_CK	PCK1
4	PB27	SPI1_NPCS3	TK0	PWML0	-	-	-	-
5	PB31	-	TF0	-	-	-	-	-
6	PD29	SCK1	DIS	-	-	-	-	-
7	PD14	CTS1	CDETb	-	-	-	-	-
8	PD15	RTS1	SPI2_SPCK	-	-	-	-	-
9	PE12	A12	TIOA1	PWMLH2	PD18	-	SENSE0	-
10	PE13	A13	TIOB1	PWML2	PD19	-	SENSE1	-
11	PC20	ISI_D1	TF1	-	-	-	-	-
12	PC19	ISI_D0	TK1	-	-	-	-	-

Table 4-9. J15 Connector Signals (Continued)

Pin No.	SAMA5D44 PIO Muxing Alternates				On-board Alternates			
13	PC22	ISI_D3	RF1	–	–	–	–	–
14	PC21	ISI_D2	TD1	–	–	–	–	–
15	PC24	ISI_D5	RK1	PCK1	–	–	–	–
16	PC23	ISI_D4	RD1	–	–	–	–	–
17	PC26	ISI_D7	TWCK3	UTXD1	–	–	–	–
18	PC25	ISI_D6	TWD3	URXD1	–	–	–	–
19	PE25	NCS1	SCK4	IRQ	PD20	–	SENSE2	–
20	PE0	A0/NBS0	MCI0_CDB	CTS4	PD21	–	SENSE3	–
21	PE28	NWAIT	RTS4	A19	–	–	–	–
22	PB1	G0_RXCK	SCK2	ISI_PCK	–	–	–	–
23	PD30	–	–	–	PD22	–	SENSE4	–
24	PD31	SPI0_NPCS2	PCK1	–	PD23	–	SENSE5	–
25	PB3	G0_TXER	CTS2	ISI_VSYNC	–	–	–	–
26	PB11	G0_RX3	RTS2	PWMH1	–	–	–	–
27	PB4	G0_CRCS	RXD2	ISI_HSYNC	PD24	–	SENSE6	–
28	PB5	G0_COL	TXD2	PCK2	PD25	–	SENSE7	–
29	PD28	SCK0	–	–	–	–	–	–
30	PD11	RTS0	SPI2_MISO	–	–	–	–	–
31	PD10	CTS0	CDETA	–	–	–	–	–
32	PD9	FIQ	–	–	–	–	–	–
33	PC3	SPI0_NPCS0	PWML3	ISI_D11	PD26	–	SENSE8	–
34	PE31	ADTRG	–	–	PD27	–	SENSE9	–
35	GND	–	–	–	GND	–	–	–
36	GND	–	–	–	GND	–	–	–

Figure 4-31. J17 Connector

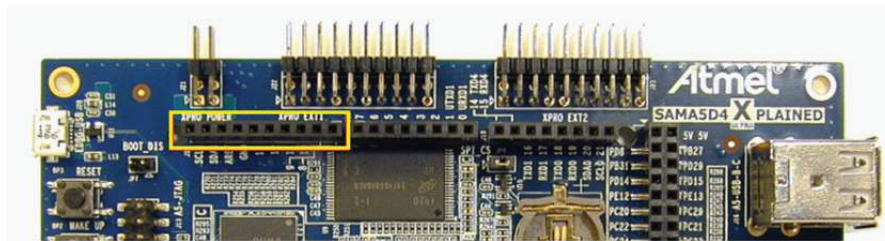
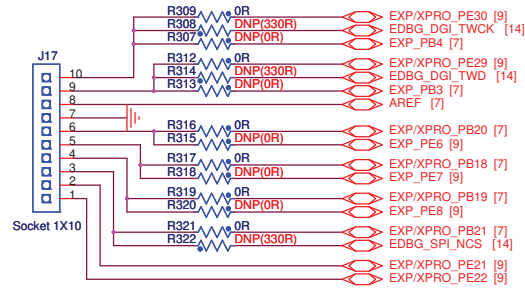

Table 4-10. J17 Connector Signals

Pin No.	SAMA5D44 PIO Muxing Alternates				On-board Alternates				EDBG Alternate
10	PE30	DIBN	UTXD0	TWCK1	PB4	G0_CRS	RXD2	ISI_HSYNC	DGI_TWI
9	PE29	DIBP	URXD0	TWD1	PB3	G0_TXER	CTS2	ISI_VSYNC	DGI_TWI
8	AREF	–	–	–	–	–	–	–	–
7	GND	–	–	–	–	–	–	–	–
6	PB20	SPI1_SPCK	D10	–	PE6	A6	TIOA3	–	–
5	PB18	SPI1_MISO	D8	–	PE7	A7	TIOB3	PWMF1	–
4	PB19	SPI1_MOSI	D9	–	PE8	A8	TCLK3	PWML3	–
3	PB21	SPI1_NPCS0	D11	–	–	–	–	–	DGI_SPI
2	PE21	A23	TIOA4	MCI1_DA1	–	–	–	–	–
1	PE22	A24	TIOB4	MCI1_DA2	–	–	–	–	–

Figure 4-32. J18 Connector

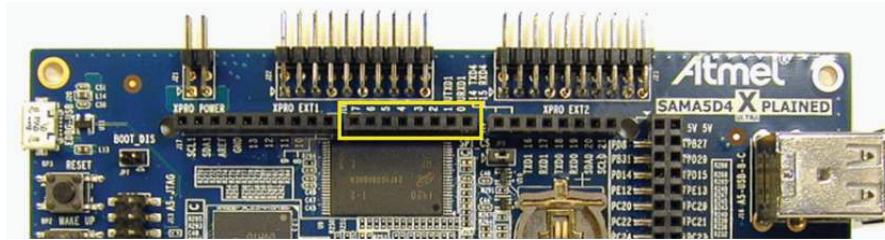
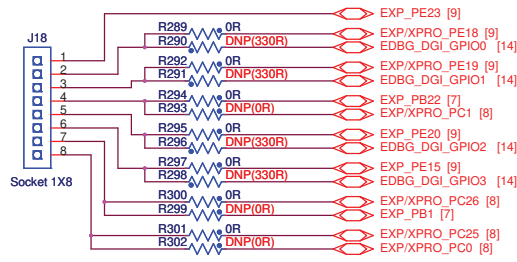

Table 4-11. J18 Connector Signals

Pin No.	SAMA5D44 PIO Muxing Alternates				On-board Alternates				EDBG Alternate
1	PE23	A25	TCLK4	MCI1_DA3	–	–	–	–	–
2	PE18	A18	TIOA5	MCI1_CK	–	–	–	–	DGI_GPIO0
3	PE19	A19	TIOB5	MCI1_CDA	–	–	–	–	DGI_GPIO1
4	PB22	SPI1_NPCS1	D12	–	PC1	SPI0_MOSI	PWML2	ISI_D9	–
5	PE20	A20	TCLK5	MCI1_DA0	–	–	–	–	DGI_GPIO2
6	PE15	A15	SCK3	TIOA0	–	–	–	–	DGI_GPIO3
7	PC26	ISI_D7	TWCK3	UTXD1	PB1	G0_RXCK	SCK2	ISI_PCK	–
8	PC25	ISI_D6	TWD3	URXD1	PC0	SPI0_MISO	PWMH2	ISI_D8	–

Figure 4-33. J19 Connector

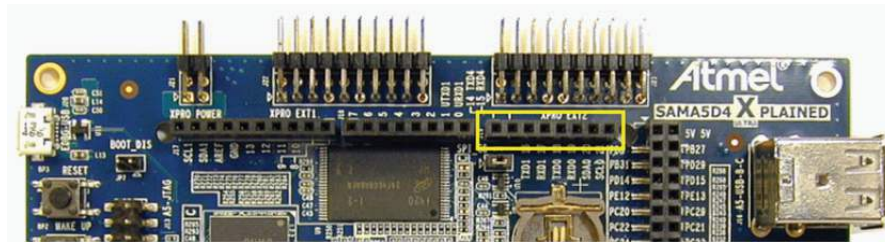
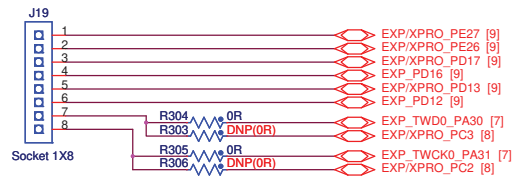

Table 4-12. J19 Connector Signals

Pin No.	SAMA5D44 PIO Muxing Alternates				On-board Alternates				
	PE27	NWR1/NBS1	TXD4	–	–	–	–	–	–
1	PE27	NWR1/NBS1	TXD4	–	–	–	–	–	–
2	PE26	NCS2	RXD4	A18	–	–	–	–	–
3	PD17	TXD1	SPI2_NPCS0	–	–	–	–	–	–
4	PD16	RXD1	DCENB	–	–	–	–	–	–
5	PD13	TXD0	SPI2_MOSI	–	–	–	–	–	–
6	PD12	RXD0	DCENA	–	–	–	–	–	–
7	PA30	TWD0	–	–	PC3	SPI0_NPCS0	PWML3	ISI_D11	
8	PA31	TWCK0	–	–	PC2	SPI0_SPCK	PWMH3	ISI_D10	

4.2.15.3 SAMA5D44 Peripheral Functions Available Through Arduino Headers

Table 4-13 provides details on access to the SAMA5D44 internal peripherals through the Arduino headers.

Note: Only one function at a time can be selected for each pin (refer to Section 4.3.15 in this document and the PIO controller section in SAMA5D4 Series datasheet).

Table 4-13. SAMA5D44 Peripheral Functions Available through the Arduino Headers

Connector	SAMA5D44 to Arduino	System Function	PCK	ISI	SSC	SPI	TWI	UART/ USART	ANALOG	MISC
J14	PB18	–	–	–	–	SPI1_MISO	–	–	–	–
	3v3/5v	3.3V/5V	–	–	–	–	–	–	–	–
	PB20	–	–	–	–	SPI1_SPCK	–	–	–	–
	PB19	–	–	–	–	SPI1_MOSI	–	–	–	–
	nRST	nRST	–	–	–	–	–	–	–	–
	GND	GND	–	–	–	–	–	–	–	–
J7	PB28	–	–	–	TD0	SPI2_NPCS3	–	–	–	PWMH1
	PC27	–	–	–	–	SPI0_NPCS2	–	–	AD0	PWML0
	PC28	–	–	–	–	SPI0_NPCS3	–	–	AD1	PWML1
	PC29	–	–	–	–	–	–	–	AD2	PWMFIO
	PC30	–	–	–	–	–	–	–	AD3	PWMH0
	PC31	–	–	–	–	–	–	–	AD4	PWMH1
	PE24	–	–	–	–	–	RTS3	–	–	–
	PE5	–	–	–	–	–	CTS3	–	–	–
J8	PB30	–	–	–	RF0	–	TWCK2	–	–	–
	PB29	–	–	–	RD0	–	TWD2	–	–	PWML1
	PB26	–	PCK0	–	RK0	–	–	–	–	PWMH0
	PB10	–	PCK2	–	–	–	–	–	–	PWML1
	PC0	–	–	ISI_D8	–	SPI0_MISO	–	–	–	PWMH2
	PC1	–	–	ISI_D9	–	SPI0_MOSI	–	–	–	PWML2
	PB14	–	–	ISI_D10	–	SPI0_SPCK	–	–	–	PWMH0
	PB15	–	–	–	–	–	–	–	–	PWML0
J17	PE30	–	–	ISI_HSYNC	–	–	TWCK1	RXD2	–	–
	PE29	–	–	ISI_VSYNC	–	–	TWD1	CTS2	–	–
	AREF	AREF	–	–	–	–	–	–	–	–
	GND	GND	–	–	–	–	–	–	–	–
	PB20	–	–	–	–	SPI1_SPCK	–	–	–	TIOA3
	PB18	–	–	–	–	SPI1_MISO	–	–	–	TIOB3
	PB19	–	–	–	–	SPI1_MOSI	–	–	–	TCLK3
	PB21	–	–	–	–	SPI1_NPCS0	–	–	–	–
	PE21	–	–	–	–	–	–	–	–	TIOA4
	PE22	–	–	–	–	–	–	–	–	TIOB4

Table 4-13. SAMA5D44 Peripheral Functions Available through the Arduino Headers (Continued)

Connector	SAMA5D44 to Arduino	System Function	PCK	ISI	SSC	SPI	TWI	UART/ USART	ANALOG	MISC
J18	PE23	–	–	–	–	–	–	–	–	TCLK4
	PE18	–	–	–	–	–	–	–	–	TIOA5
	PE19	–	–	–	–	–	–	–	–	TIOB5
	PB22	–	–	ISI_D9	–	SPI1_NPCS1	–	–	–	–
	PE20	–	–	–	–	SPI2_NPCS1	–	–	–	TCLK5
	PE15	–	–	–	–	SPI2_NPCS2	–	–	–	TIOA0
	PC26	–	–	ISI_D8	–	–	TWCK3	UTXD1	–	PWMH2
	PC25	–	–	ISI_PCK	–	–	TWD3	URXD1	–	–
J19	PE27	–	–	–	–	–	–	TXD4	–	–
	PE26	–	–	–	–	–	–	RXD4	–	–
	PD17	–	–	–	–	SPI2_NPCS0	–	TXD1	–	–
	PD16	–	–	–	–	–	–	RXD1	–	–
	PD13	–	–	–	–	SPI2_MOSI	–	TXD0	–	–
	PD12	–	–	–	–	–	–	RXD0	–	–
	PA30	–	–	ISI_D11	–	SPI0_NPCS0	TWD0	–	–	PWML3
	PA31	–	–	ISI_D10	–	SPI0_SPCK	TWCK0	–	–	PWMH3

Table 4-13. SAMA5D44 Peripheral Functions Available through the Arduino Headers (Continued)

Connector	SAMA5D44 to Arduino	System Function	PCK	ISI	SSC	SPI	TWI	UART/ USART	ANALOG	MISC	
J15	5V	5V	–	–	–	–	–	–	–	–	
	5V	5V	–	–	–	–	–	–	–	–	
	PD8	–	PCK0/PC K1	–	TK0	–	–	TXD2	–	–	
	PB27	–	–	–	TF0	SPI1_NPCS3	–	–	–	PWML0	
	PB31	–	–	–	–	–	–	–	–	–	
	PD29	–	–	–	–	–	–	SCK1	–	–	
	PD14	–	–	–	–	–	TWD0	CTS1	–	–	
	PD15	–	–	–	–	–	SPI2_SPCK	TWCK0	RTS1	–	–
	PE12	–	–	–	–	–	–	–	–	PWMH2	
	PE13	–	–	–	–	–	–	–	–	PWML2	
	PC20	–	–	–	ISI_D1	TF1	–	–	–	–	
	PC19	–	–	–	ISI_D0	TK1	–	–	–	–	
	PC22	–	–	–	ISI_D3	RF1	–	–	–	–	
	PC21	–	–	–	ISI_D2	TD1	–	–	–	–	
	PC24	–	–	PCK1	ISI_D5	RK1	–	–	–	–	
	PC23	–	–	–	ISI_D4	RD1	–	–	–	–	
	PC26	–	–	–	ISI_D7	–	–	TWCK3	UTXD1	–	–
	PC25	–	–	–	ISI_D6	–	–	TWD3	URXD1	–	–
	PE25	–	–	–	–	–	SPI0_MOSI	–	SCK4	–	–
	PE0	–	–	–	–	–	SPI0_MISO	–	CTS4	–	–
	PE28	–	–	–	–	–	SPI0_NPCS0	–	RTS4	–	–
	PB1	–	–	–	–	–	SPI0_SPCK	–	SCK2	–	–
	PD30	–	–	–	–	–	–	–	–	–	–
	PD31	–	–	PCK1	–	–	SPI0_NPCS2	–	–	–	–
	PB3	–	–	–	–	–	–	–	CTS2	–	–
	PB11	–	–	–	–	–	–	–	RTS2	–	PWMH1
	PB4	–	–	–	–	–	–	–	RXD2	–	–
	PB5	–	–	PCK2	–	–	–	–	TXD2	–	–
	PD28	–	–	–	–	–	–	–	SCK0	–	–
	PD11	–	–	–	–	–	–	–	RTS0	–	–
	PD10	–	–	–	–	–	–	–	CTS0	–	–
	PD9	–	–	–	–	–	–	–	–	–	–
PC3	–	–	–	ISI_D11	–	SPI0_NPCS0	–	–	–	PWML3	
PE31	–	–	–	–	–	–	–	–	–	–	
GND	GND	–	–	–	–	–	–	–	–	–	
GND	GND	–	–	–	–	–	–	–	–	–	

4.2.15.4 XPRO

The SAMA5D4-XULT board embeds three connectors to interface Xplained PRO wings.

Figure 4-34. XPRO Connectors

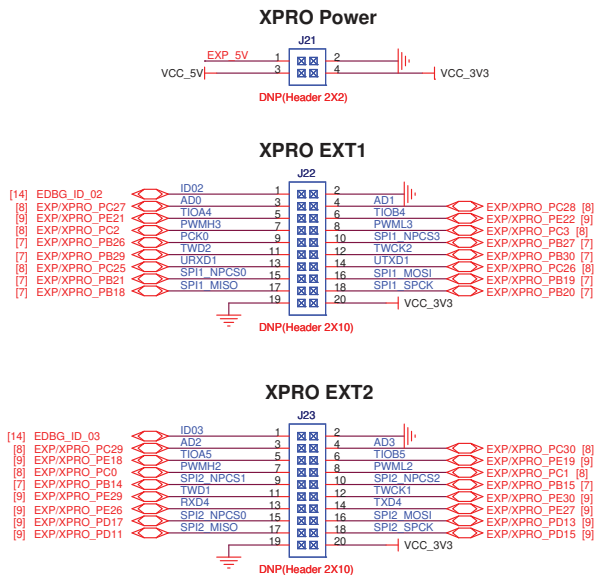

XPRO Connectors

The standard extension headers include common signals. These are male 20-pin/100-mil/right-angled headers (extension boards feature a female 20-pin straight header).

Figure 4-35. XPRO Extension Headers

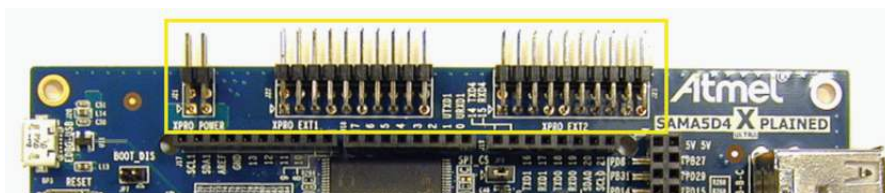

4.3 PIO Usage and Interface Connectors

4.3.1 Power Supply

Figure 4-36. Power Supply Connector J4

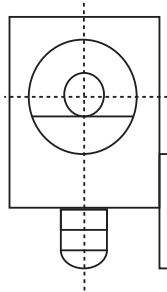

Table 4-14. Power Supply Connector J4 Signal Description

Pin	Mnemonic	Signal Description
1	Center pin	+5V
2	Spring blade	GND
3	Fixing pin	Floating

4.3.2 JTAG/ICE Connector

Figure 4-37. JTAG J13

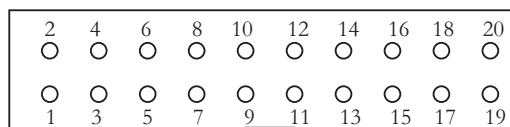

Table 4-15. JTAG/ICE Connector J13 Signal Descriptions

Pin	Mnemonic	Signal Description
1	VTref. 3.3V power	This is the target reference voltage (main 3.3V).
2	Vsupply. 3.3V power	This pin is not connected in SAM-ICE™ and reserved for compatibility with other equipment. Connected to main 3.3V.
3	nTRST TARGET RESET - Active-low output signal that resets the target	JTAG Reset. Output from SAM-ICE to control the Reset signal on the target system.
4	GND	Common ground
5	TDI TEST DATA INPUT - Serial data output line, sampled on the rising edge of the TCK signal	JTAG data input into target CPU
6	GND	Common ground
7	TMS TEST MODE SELECT	JTAG mode set input into target CPU
8	GND	Common ground
9	TCK TEST CLOCK - Output timing signal, for synchronizing test logic and control register access	JTAG clock signal into target CPU
10	GND	Common ground
11	RTCK - Input Return test clock signal from the target	Some targets having too slow system clock must synchronize the JTAG inputs to internal clocks. In present case such synchronization is unneeded and TCK merely looped back into RTCK.
12	GND	Common ground
13	TDO JTAG TEST DATA OUTPUT - Serial data input from the target	JTAG data output from target CPU
14	GND	Common ground
15	nSRST RESET	Active-low reset signal. Target CPU reset signal.
16	GND	Common ground
17	RFU	This pin is not connected in SAM-ICE.
18	GND	Common ground
19	RFU	This pin is not connected in SAM-ICE.
20	GND	Common ground

4.3.3 EDBG USB Type Micro-AB

Figure 4-38. EDBG USB Type Micro-AB Connector J20

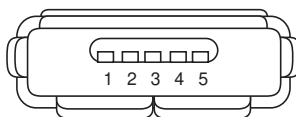

Table 4-16. EDBG USB Type Micro-AB Connector J20 Signal Descriptions

Pin	Mnemonic	Signal Description
1	Vbus	5V power
2	DM	Data minus
3	DP	Data plus
4	ID	On-the-go identification
5	GND	Common ground

4.3.4 USB Type A Dual Port

Figure 4-39. USB Type A Dual Port J16

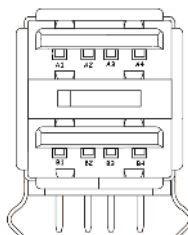

Table 4-17. USB Type A Dual Port J16 Signal Descriptions

Pin	Mnemonic	Signal Description
A1	Vbus - USB_A	5V power
A2	DM - USB_A	Data minus
A3	DP - USB_A	Data plus
A4	GND	Common ground
B1	Vbus - USB_A	5V power
B2	DM - USB_A	Data minus
B3	DP - USB_A	Data plus
B4	GND	Common ground
Mechanical pins	–	Shield

4.3.5 USB Micro-AB

Figure 4-40. USB Host/Device Micro-AB Connector J11

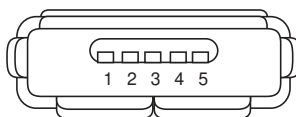

Table 4-18. USB Host/Device Micro-AB Connector J11 Signal Descriptions

Pin	Mnemonic	Signal Description
1	Vbus	5V power
2	DM	Data minus
3	DP	Data plus
4	ID	On-the-go identification
5	GND	Common ground

4.3.6 DEBUG Connector

Figure 4-41. DEBUG Connector J1



Table 4-19. DEBUG Connector J1 Signal Descriptions

Pin	Mnemonic	PIO	Signal Description
1	CTS3	PE5	Handshake input
2	TXD3 (Transmitted Data)	PE17	RS232 serial data input signal
3	RXD3 (Received Data)	PE16	RS232 serial data output signal
4	Power	–	5V/3.3V (selected by resistors)
5	RTS3	PE24	Handshake output
6	GND	–	Common ground

4.3.7 SD/MMC Plus MCI0

Figure 4-42. SD/MMC Socket J24

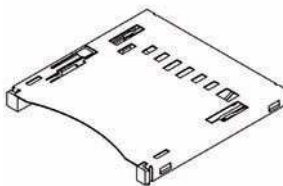

Table 4-20. SD/MMC Socket J24 Signal Descriptions

Pin	Mnemonic	PIO	Signal Description
1	DAT3	PE23	Data Bit
2	CMD	PE19	Command Line
3	VSS	–	Common ground
4	VCC	–	Supply Voltage 3.3V
5	CLK	PE18	Clock / Command Line
6	CD	PE3	Card Detect
7	DAT0	PE20	Data Bit
8	DAT1	PE21	Data Bit
9	DAT2	PE22	Data Bit
10	–	Not connected	Data Bit
11	–	Not connected	Data Bit
12	–	Not connected	Data Bit
13	–	Not connected	Data Bit
14	WP	GND	Write Protection (deactivated)
15	VSS	–	Common ground
16	VSS	–	Common ground

4.3.8 MicroSD MCI1

Figure 4-43. MicroSD Socket J9

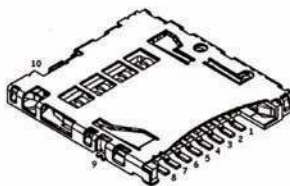

Table 4-21. MicroSD Socket J9 Signal Descriptions

Pin	Mnemonic	PIO	Signal Description
1	DAT2	PC8	Data Bit 2
2	CD/DAT3	PC9	Card Detect / Data Bit 3
3	CMD	PC5	Command Line
4	VCC	–	Supply Voltage 3.3V
5	CLK	PC4	Clock / Command Line
6	VSS	–	Common ground
7	DAT0	PC6	Data Bit 0
8	DAT1	PC7	Data Bit 1
9	CD	PE2	Card Detect
10	GND	–	Common ground

4.3.9 Ethernet ETH0 RJ45 Socket J12

Figure 4-44. Ethernet RJ45 Socket J12

1 2 3 4 5 6 7 8

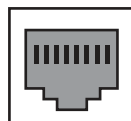

RJ-45

4.3.10 LCD Connector J2

Figure 4-45. LCD Connector J2



Table 4-22. LCD Connector J2 Signal Descriptions

Pin	Signal	PIO	Signal	RGB Interface Function	Alternate
1	ID_SYS	PE15 / ID00	ID	Extension module identification	EDBG_ID_01
2	–	GND	GND	GND	–
3	LCDDAT0	PA0	D0	Data line	–
4	LCDDAT1	PA1	D1	Data line	–
5	LCDDAT2	PA2	D2	Data line	–
6	LCDDAT3	PA3	D3	Data line	–
7	–	GND	GND	GND	–
8	LCDDAT4	PA4	D4	Data line	–
9	LCDDAT5	PA5	D5	Data line	–
10	LCDDAT6	PA6	D6	Data line	–
11	LCDDAT7	PA7	D7	Data line	–
12	–	GND	GND	GND	–
13	LCDDAT8	PA8	D8	Data line	–
14	LCDDAT9	PA9	D9	Data line	–
15	LCDDAT10	PA10	D10	Data line	–
16	LCDDAT11	PA11	D11	Data line	–
17	–	GND	GND	GND	–
18	LCDDAT12	PA12	D12	Data line	–
19	LCDDAT13	PA13	D13	Data line	–
20	LCDDAT14	PA14	D14	Data line	–
21	LCDDAT15	PA15	D15	Data line	–
22	–	GND	GND	GND	–
23	LCDDAT16	PC14	D16	Data line	–
24	LCDDAT17	PC13	D17	Data line	–
25	LCDDAT18	PC12	D18	Data line	–
26	LCDDAT19	PC11	D19	Data line	–
27	–	GND	GND	GND	–
28	LCDDAT20	PC10	D20	Data line	–
29	LCDDAT21	PC15	D21	Data line	–
30	LCDDAT22	PE27	D22	Data line	–

Table 4-22. LCD Connector J2 Signal Descriptions (Continued)

Pin	Signal	PIO	Signal	RGB Interface Function	Alternate	
31	LCDDAT23	PE28	D23	Data line	–	
32	–	GND	GND	GND	–	
33	LCDPCK	PA28	PCLK	Pixel clock	–	
34	LCDVSYNC	PA26	VSYNC/CS	Vertical sync	–	
35	LCDHSYNC	PA27	HSYNC/WE	Horizontal sync	–	
36	LCDDEN	PA29	DATA_ENABLE/RE	Data enable	–	
37	SPI1_SPCK	PB20	SPI_SCK	–	AD3/YM	PC30
38	SPI1_MOSI	PB19	SPI_MOSI	–	AD2/YP	PC29
39	SPI1_MISO	PB18	SPI_MISO	–	AD1/XM	PC28
40	SPI1_NPCS2	PB23	SPI_CS	–	AD0/XP	PC27
41	LCDDISP	PA25	ENABLE	Display enable signal	–	
42	TWD0	PA30	TWI_SDA	I2C data line (maXTouch®)	–	
43	TWCK0	PA31	TWI_SCL	I2C clock line (maXTouch)	–	
44	GPIO	PE9	IRQ1	maXTouch interrupt line	–	
45	GPIO	PE10	IRQ2	Interrupt line for other I2C devices	–	
46	LCDPWM	PA26	PWM	Backlight control	–	
47	RESET	–	RESET	Reset for both display and maXTouch	–	
48	Main_5v/3v3	VCC	VCC	3.3V or 5V supply (0R)	–	
49	Main_5v/3v3	VCC	VCC	3.3V or 5V supply (0R)	–	
50	GND	GND	GND	GND	–	

4.3.11 HDMI Connector

Figure 4-46. HDMI Type A Female Connector J5

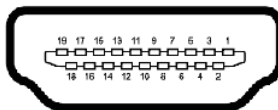

Table 4-23. HDMI Type A Female Connector J5 Signal Descriptions

Signal	Pin No.		Signal
TMDS Data 2+	1	2	TMDS Data 2 Shield
TMDS Data 2-	3	4	TMDS Data 1+
TMDS Data 1 Shield	5	6	TMDS Data 1-
TMDS Data 0+	7	8	TMDS Data 0 Shield
TMDS Data 0-	9	10	TMDS Clock +
TMDS Clock Shield	11	12	TMDS Clock -
CEC (not connected)	13	14	Not connected
SCL	15	16	SDA
GND	17	18	+5V
Hot Plug Detect	19	20	DDC/CEC (GND)

4.3.12 XPRO Power Connector

Figure 4-47. XPRO Power Connector J21

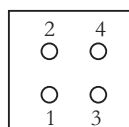

Table 4-24. XPRO Power Connector J21 Signal Descriptions

Signal	Pin No.		Signal
EXP_5V	1	2	GND
VCC_5V	3	4	VCC_3v3

4.3.13 XPRO Ext1 Connector

Figure 4-48. XPRO Ext1 Connector J22

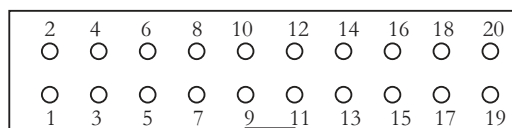

Table 4-25. XPRO Ext1 Connector J22 Signal Descriptions

SAMA5D44		XPRO Signal	Pin No.		XPRO Signal	SAMA5D44	
Function	Pin					Function	Pin
ID02 ⁽¹⁾	EDBG ⁽¹⁾	ID	1	2	GND	–	–
AD0	PC27	ADC(+)	3	4	ADC(-)	PC28	AD1
TIOA4	PE21	GPIO	5	6	GPIO	PE22	TIOBA4
PWMH3	PC2	PWM(+)	7	8	PWM(-)	PC3	PWML3
PCK0	PB26	IRQ/GPIO	9	10	SPI_SS_B/GPIO	PB27	SPI1_NPCS3
TWD2	PB29	TWI_SDA	11	12	TWI_SCL	PB30	TWCK2
URXD1	PC25	UART_RX	13	14	UART_TX	PC26	UTXD1
SPI1_NPCS0	PB21	SPI_SS_A	15	16	SPI_MOSI	PB19	SPI1_MOSI
SPI1_MISO	PB18	SPI_MISO	17	18	SPI_SCK	PB20	SPI1_SPCK
–	–	GND	19	20	VCC 3v3	–	–

Note: 1. Used by the EDBG interface.

4.3.14 XPRO Ext2 Connector

Figure 4-49. XPRO Ext2 Connector J23

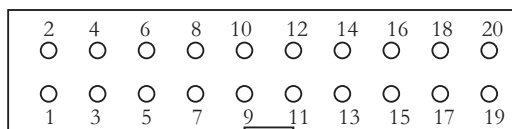

Table 4-26. XPRO Ext2 Connector J23 Signal Descriptions

SAMA5D44		XPRO Signal	Pin No.		XPRO Signal	SAMA5D44	
Function	Pin					Function	Pin
ID03 ⁽¹⁾	EDBG ⁽¹⁾	ID	1	2	GND	–	–
AD2	PC29	ADC(+)	3	4	ADC(-)	PC30	AD3
TIOA5	PE18	GPIO	5	6	GPIO	PE19	TIOB5
PWMH2	PC0	PWM(+)	7	8	PWM(-)	PC1	PWML2
SPI2_NPCS1	PB14	IRQ/GPIO	9	10	SPI_SS_B/GPIO	PB15	SPI2_NPCS2
TWD1	PE29	TWI_SDA	11	12	TWI_SCL	PE30	TWCK1
RXD4	PE26	UART_RX	13	14	UART_TX	PE27	TXD4
SPI2_NPCS0	PD17	SPI_SS_A	15	16	SPI_MOSI	PD13	SPI2_MOSI
SPI2_MISO	PD11	SPI_MISO	17	18	SPI_SCK	PD15	SPI2_SPCK
–	–	GND	19	20	VCC 3v3	–	–

Note: 1. Used by the EDBG interface.

4.3.15 PIO Usage

The following tables provide the use of different PIO lines on the SAMA5D4-XULT, sorted by PIO lines. Most of the signals can also be configured as either inputs or outputs from/to the processor.

Table 4-27. PIO A Pin Assignment and Signal Description

Power Rail	I/O Type	Primary Signal	Peripheral A Signal	Peripheral B Signal	Peripheral C Signal
VDDIOP	GPIO	PA0	LCDDAT0	–	TMS
VDDIOP	GPIO	PA1	LCDDAT1	–	–
VDDIOP	GPIO_CLK	PA2	LCDDAT2	G1_TXCK	–
VDDIOP	GPIO_CLK	PA3	LCDDAT3	G1_RXCK	–
VDDIOP	GPIO	PA4	LCDDAT4	G1_TXEN	–
VDDIOP	GPIO	PA5	LCDDAT5	G1_TXER	–
VDDIOP	GPIO	PA6	LCDDAT6	G1_CRS	–
VDDIOP	GPIO	PA7	LCDDAT7	–	–
VDDIOP	GPIO	PA8	LCDDAT8	–	TCK
VDDIOP	GPIO	PA9	LCDDAT9	–	–
VDDIOP	GPIO	PA10	LCDDAT10	G1_RXDV	–
VDDIOP	GPIO	PA11	LCDDAT11	G1_RXER	–
VDDIOP	GPIO	PA12	LCDDAT12	G1_RX0	–
VDDIOP	GPIO	PA13	LCDDAT13	G1_RX1	–
VDDIOP	GPIO	PA14	LCDDAT14	G1_TX0	–
VDDIOP	GPIO	PA15	LCDDAT15	G1_TX1	–
VDDIOP	GPIO	PA16	LCDDAT16	–	NTRST
VDDIOP	GPIO	PA17	LCDDAT17	–	–
VDDIOP	GPIO	PA18	LCDDAT18	G1_RX2	–
VDDIOP	GPIO	PA19	LCDDAT19	G1_RX3	–
VDDIOP	GPIO	PA20	LCDDAT20	G1_TX2	–
VDDIOP	GPIO	PA21	LCDDAT21	G1_TX3	–
VDDIOP	GPIO	PA22	LCDDAT22	G1_MDC	–
VDDIOP	GPIO	PA23	LCDDAT23	G1_MDIO	–
VDDIOP	GPIO_CLK	PA24	LCDPWM	PCK0	–
VDDIOP	GPIO	PA25	LCDDISP	TD0	–
VDDIOP	GPIO	PA26	LCDVSYNC	PWMH0	SPI1_NPCS1
VDDIOP	GPIO	PA27	LCDHSYNC	PWML0	SPI1_NPCS2
VDDIOP	GPIO_CLK2	PA28	LCDPCK	PWMH1	SPI1_NPCS3
VDDIOP	GPIO	PA29	LCDDEN	PWML1	–
VDDIOP	GPIO	PA30	TWD0	–	–
VDDIOP	GPIO	PA31	TWCK0	–	–

Table 4-28. PIO B Pin Assignment and Signal Description

Power Rail	I/O Type	Primary Signal	Peripheral A Signal	Peripheral B Signal	Peripheral C Signal
VDDIOP	GPIO_CLK	PB0	G0_TXCK	–	–
VDDIOP	GPIO_CLK	PB1	G0_RXCK	SCK2	ISI_PCK
VDDIOP	GPIO	PB2	G0_TXEN	–	–
VDDIOP	GPIO	PB3	G0_TXER	CTS2	ISI_VSYNC
VDDIOP	GPIO	PB4	G0_CRCS	RXD2	ISI_HSYNC
VDDIOP	GPIO	PB5	G0_COL	TXD2	PCK2
VDDIOP	GPIO	PB6	G0_RXDV	–	–
VDDIOP	GPIO	PB7	G0_RXER	–	–
VDDIOP	GPIO	PB8	G0_RX0	–	–
VDDIOP	GPIO	PB9	G0_RX1	–	–
VDDIOP	GPIO_CLK	PB10	G0_RX2	PCK2	PWML1
VDDIOP	GPIO	PB11	G0_RX3	RTS2	PWMH1
VDDIOP	GPIO	PB12	G0_TX0	–	–
VDDIOP	GPIO	PB13	G0_TX1	–	–
VDDIOP	GPIO	PB14	G0_TX2	SPI2_NPCS1	PWMH0
VDDIOP	GPIO	PB15	G0_TX3	SPI2_NPCS2	PWML0
VDDIOP	GPIO	PB16	G0_MDC	–	–
VDDIOP	GPIO	PB17	G0_MDIO	–	–
VDDIOP	GPIO	PB18	SPI1_MISO	D8	–
VDDIOP	GPIO	PB19	SPI1_MOSI	D9	–
VDDIOP	GPIO_CLK	PB20	SPI1_SPCK	D10	–
VDDIOP	GPIO	PB21	SPI1_NPCS0	D11	–
VDDIOP	GPIO	PB22	SPI1_NPCS1	D12	–
VDDIOP	GPIO	PB23	SPI1_NPCS2	D13	–
VDDIOP	GPIO	PB24	DRXD	D14	TDI
VDDIOP	GPIO	PB25	DTXD	D15	TDO
VDDIOP	GPIO_CLK	PB26	PCK0	RK0	PWMH0
VDDIOP	GPIO	PB27	SPI1_NPCS3	TK0	PWML0
VDDIOP	GPIO	PB28	SPI2_NPCS3	TD0	PWMH1
VDDIOP	GPIO	PB29	TWD2	RD0	PWML1
VDDIOP	GPIO	PB30	TWCK2	RF0	–
VDDIOP	GPIO	PB31	–	TF0	–

Table 4-29. PIO C Pin Assignment and Signal Description

Power Rail	I/O Type	Primary Signal	Peripheral A Signal	Peripheral B Signal	Peripheral C Signal
VDDIOM	GPIO	PC0	SPI0_MISO	PWMH2	ISI_D8
VDDIOM	GPIO	PC1	SPI0_MOSI	PWML2	ISI_D9
VDDIOM	GPIO_CLK	PC2	SPI0_SPCK	PWMH3	ISI_D10
VDDIOM	GPIO	PC3	SPI0_NPCS0	PWML3	ISI_D11
VDDIOM	MCI_CLK	PC4	SPI0_NPCS1	MCI0_CK	PCK1
VDDIOM	GPIO	PC5	D0	MCI0_CDA	–
VDDIOM	GPIO	PC6	D1	MCI0_DA0	–
VDDIOM	GPIO	PC7	D2	MCI0_DA1	–
VDDIOM	GPIO	PC8	D3	MCI0_DA2	–
VDDIOM	GPIO	PC9	D4	MCI0_DA3	–
VDDIOM	GPIO	PC10	D5	MCI0_DA4	–
VDDIOM	GPIO	PC11	D6	MCI0_DA5	–
VDDIOM	GPIO	PC12	D7	MCI0_DA6	–
VDDIOM	GPIO	PC13	NRD/NANDOE	MCI0_DA7	–
VDDIOM	GPIO	PC14	NWE/NANDWE	–	–
VDDIOM	GPIO	PC15	NCS3	–	–
VDDIOM	GPIO	PC16	NANDRDY	–	–
VDDIOM	GPIO	PC17	A21/NANDALE	–	–
VDDIOM	GPIO	PC18	A22/NANDCLE	–	–
VDDIOM	GPIO	PC19	ISI_D0	TK1	–
VDDIOM	GPIO	PC20	ISI_D1	TF1	–
VDDIOM	GPIO	PC21	ISI_D2	TD1	–
VDDIOM	GPIO	PC22	ISI_D3	RF1	–
VDDIOM	GPIO	PC23	ISI_D4	RD1	–
VDDIOM	GPIO	PC24	ISI_D5	RK1	PCK1
VDDIOM	GPIO	PC25	ISI_D6	TWD3	URXD1
VDDIOM	GPIO	PC26	ISI_D7	TWCK3	UTXD1
VDDANA	GPIO_ANA	PC27	AD0	SPI0_NPCS1	PWML0
VDDANA	GPIO_ANA	PC28	AD1	SPI0_NPCS2	PWML1
VDDANA	GPIO_ANA	PC29	AD2	SPI0_NPCS3	PWMFIO
VDDANA	GPIO_ANA	PC30	AD3	–	PWMH0
VDDANA	GPIO_ANA	PC31	AD4	–	PWMH1

Table 4-30. PIO D Pin Assignment and Signal Description

PIOD Mode Secure		Primary Signal	Peripheral A Signal	Peripheral B Signal	Peripheral C Signal
Power Rail	I/O Type				
VDDIOP	GPIO_CLK	PD8	PCK0	–	–
VDDIOP	GPIO	PD9	FIQ	–	–
VDDIOP	GPIO	PD10	CTS0	CDETA	–
VDDIOP	GPIO	PD11	RTS0	SPI2_MISO	–
VDDIOP	GPIO	PD12	RXD0	DCENA	–
VDDIOP	GPIO	PD13	TXD0	SPI2_MOSI	–
VDDIOP	GPIO	PD14	CTS1	CDETB	–
VDDIOP	GPIO	PD15	RTS1	SPI2_SPCK	–
VDDIOP	GPIO	PD16	RXD1	DCENB	–
VDDIOP	GPIO	PD17	TXD1	SPI2_NPCS0	–
VDDANA	GPIO_ANA	PD18	–	SENSE0	–
VDDANA	GPIO_ANA	PD19	–	SENSE1	–
VDDANA	GPIO_ANA	PD20	–	SENSE2	–
VDDANA	GPIO_ANA	PD21	–	SENSE3	–
VDDANA	GPIO_ANA	PD22	–	SENSE4	–
VDDANA	GPIO_ANA	PD23	–	SENSE5	–
VDDANA	GPIO_ANA	PD24	–	SENSE6	–
VDDANA	GPIO_ANA	PD25	–	SENSE7	–
VDDANA	GPIO_ANA	PD26	–	SENSE8	–
VDDANA	GPIO_ANA	PD27	–	SENSE9	–
VDDIOP	GPIO_CLK	PD28	SCK0	–	–
VDDIOP	GPIO_CLK	PD29	SCK1	DIS	–
VDDIOP	GPIO	PD30	–	–	–
VDDIOP	GPIO_CLK	PD31	SPI0_NPCS2	PCK1	–

Table 4-31. PIO E Pin Assignment and Signal Description

Power Rail	I/O Type	Primary Signal	Peripheral A Signal	Peripheral B Signal	Peripheral C Signal
VDDIOM	MCI_CLK	PE0	A0/NBS0	MCI0_CDB	CTS4
VDDIOM	EBI	PE1	A1	MCI0_DB0	–
VDDIOM	EBI	PE2	A2	MCI0_DB1	–
VDDIOM	EBI	PE3	A3	MCI0_DB2	–
VDDIOM	EBI	PE4	A4	MCI0_DB3	–
VDDIOM	EBI	PE5	A5	CTS3	–
VDDIOM	EBI	PE6	A6	TIOA3	–
VDDIOM	EBI	PE7	A7	TIOB3	PWMF11
VDDIOM	EBI	PE8	A8	TCLK3	PWML3
VDDIOM	EBI	PE9	A9	TIOA2	–
VDDIOM	EBI	PE10	A10	TIOB2	–
VDDIOM	EBI	PE11	A11	TCLK2	–
VDDIOM	EBI	PE12	A12	TIOA1	PWMH2
VDDIOM	EBI	PE13	A13	TIOB1	PWML2
VDDIOM	EBI	PE14	A14	TCLK1	PWMH3
VDDIOM	EBI	PE15	A15	SCK3	TIOA0
VDDIOM	EBI	PE16	A16	RXD3	TIOB0
VDDIOM	EBI	PE17	A17	TXD3	TCLK0
VDDIOM	EBI	PE18	A18	TIOA5	MCI1_CK
VDDIOM	EBI	PE19	A19	TIOB5	MCI1_CDA
VDDIOM	EBI	PE20	A20	TCLK5	MCI1_DA0
VDDIOM	EBI	PE21	A23	TIOA4	MCI1_DA1
VDDIOM	EBI	PE22	A24	TIOB4	MCI1_DA2
VDDIOM	EBI	PE23	A25	TCLK4	MCI1_DA3
VDDIOM	EBI	PE24	NCS0	RTS3	–
VDDIOM	EBI	PE25	NCS1	SCK4	IRQ
VDDIOM	EBI	PE26	NCS2	RXD4	A18
VDDIOM	EBI	PE27	NWR1/NBS1	TXD4	–
VDDIOM	EBI	PE28	NWAIT	RTS4	A19
VDDIOP	DIB	PE29	DIBP	URXD0	TWD1
VDDIOP	DIB	PE30	DIBN	UTXD0	TWCK1
VDDIOP	GPIO	PE31	ADTRG	–	–

4.4 SAMA5D4-XULT Board Schematics

This section contains the following schematics:

- [Block diagram](#)
- [PIO Muxing Table](#)
- [Power Supply](#)
- [SAMA5D44 - Power](#)
- [SAMA5D44 - DDR2](#)
- [SAMA5D44 - PIOA and PIOB](#)
- [SAMA5D44 - PIOC and Flash](#)
- [SAMA5D44 - SYS, PIOD, and PIOE](#)
- [JTAG, USB, DEBUG, and LCD](#)
- [HDMI](#)
- [Ethernet_ETH0_10/100M](#)
- [HSMCI](#)
- [EDBG](#)
- [Expansion and XPRO Connectors](#)

Figure 4-50. Block diagram

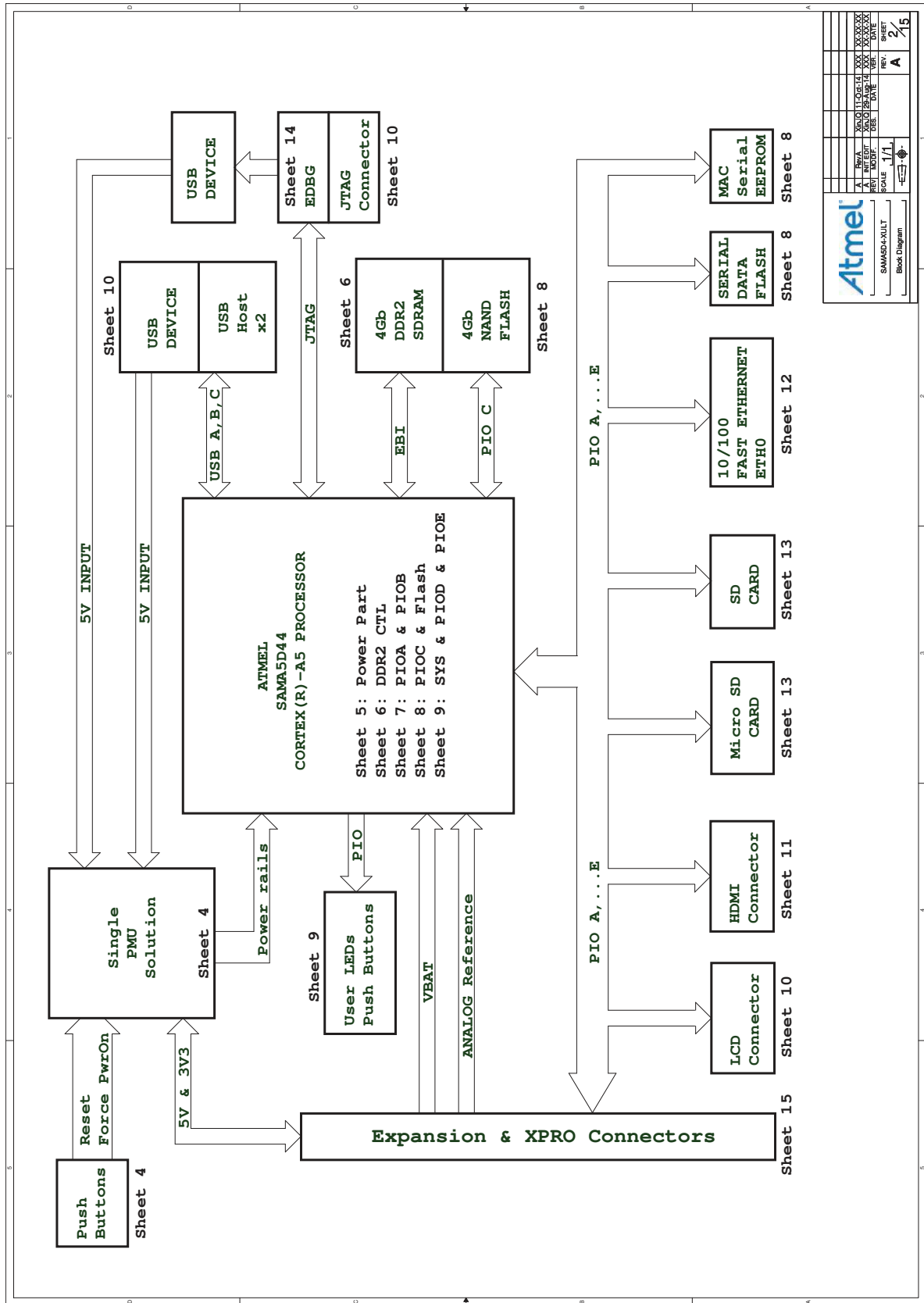
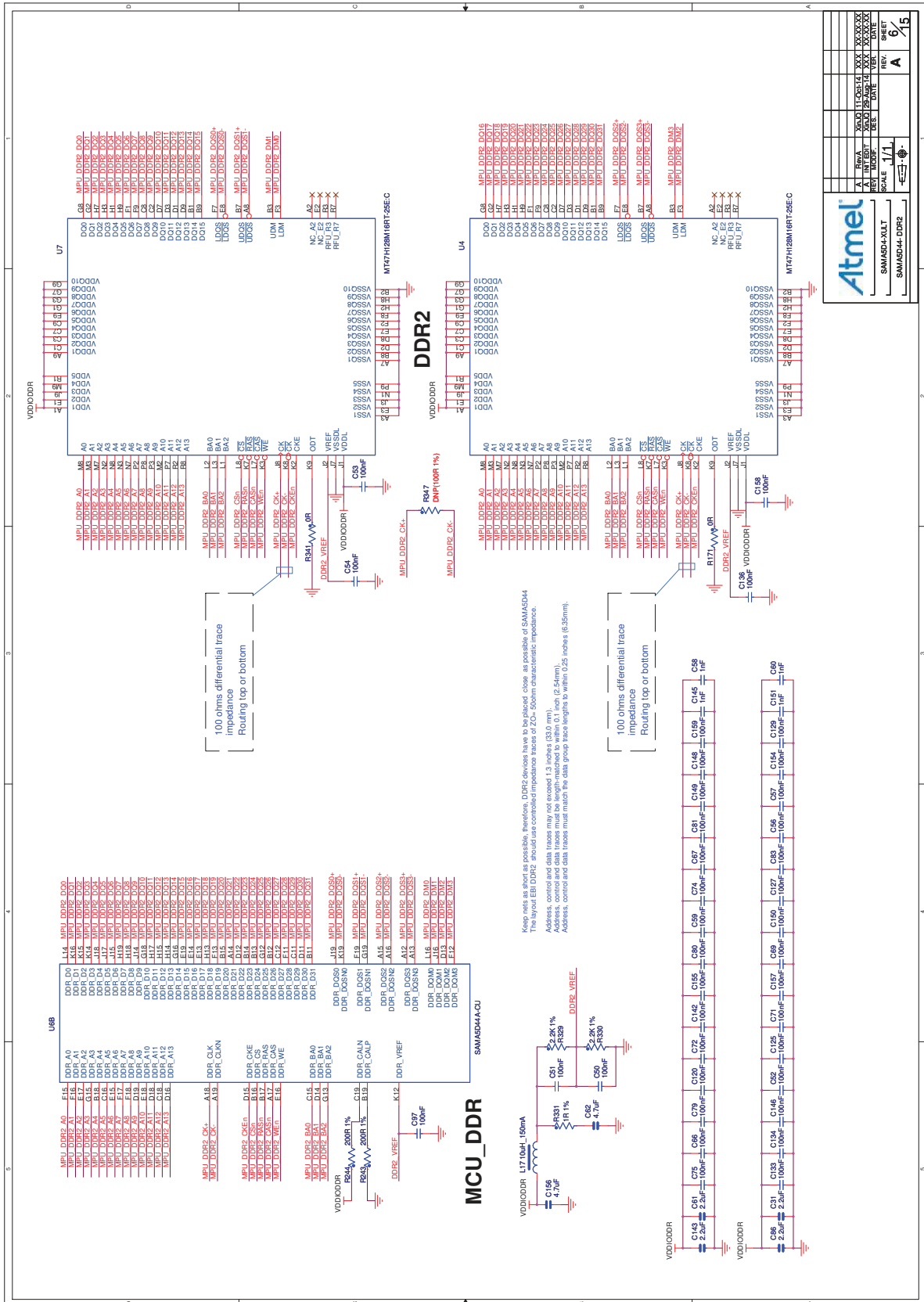
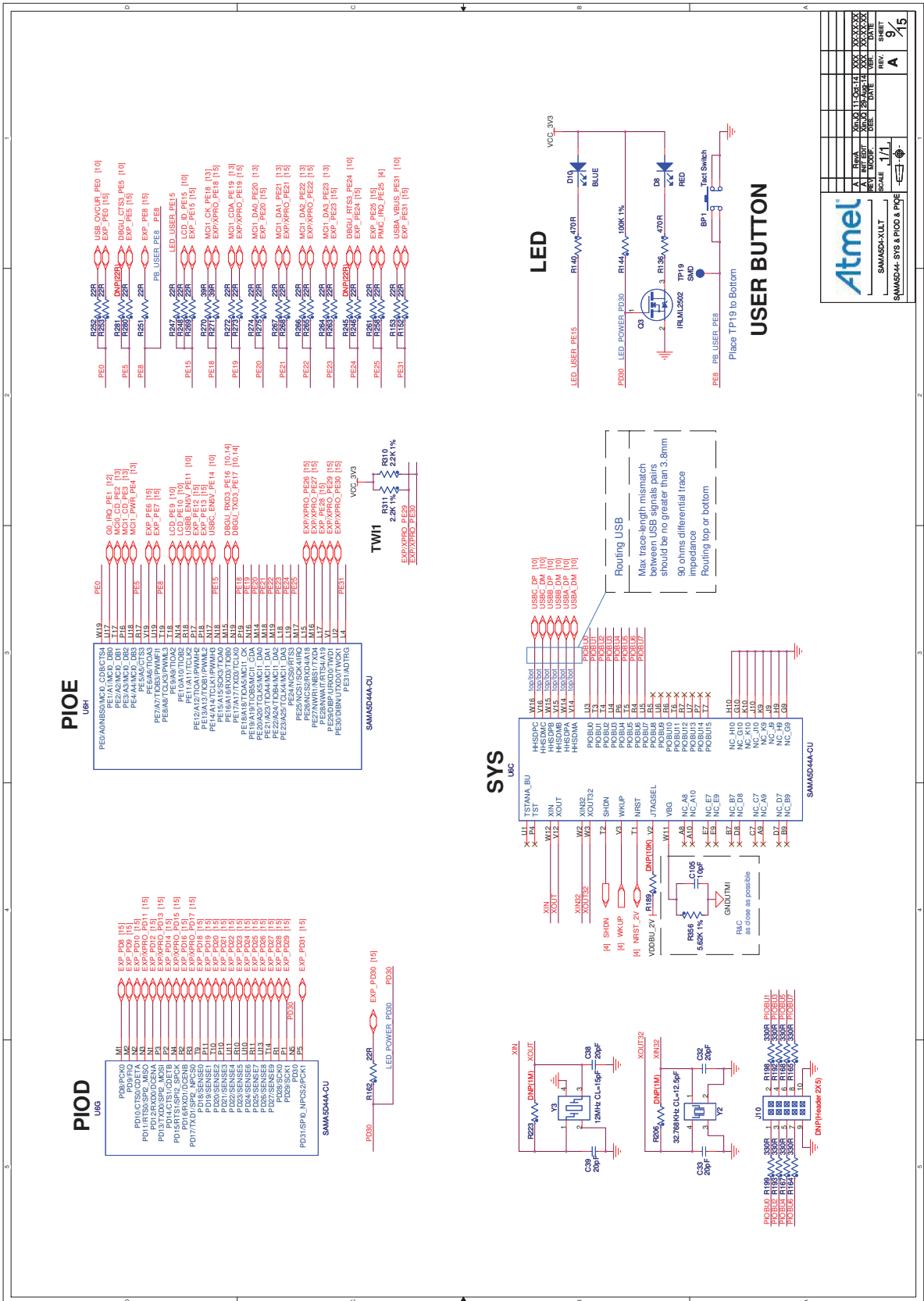

Figure 4-54. SAMA5D44 - DDR2



REV A	XXX	XXX	XXX	XXX
REV B	XXX	XXX	XXX	XXX
REV C	XXX	XXX	XXX	XXX
REV D	XXX	XXX	XXX	XXX
REV E	XXX	XXX	XXX	XXX
REV F	XXX	XXX	XXX	XXX
REV G	XXX	XXX	XXX	XXX
REV H	XXX	XXX	XXX	XXX
REV I	XXX	XXX	XXX	XXX
REV J	XXX	XXX	XXX	XXX
REV K	XXX	XXX	XXX	XXX
REV L	XXX	XXX	XXX	XXX
REV M	XXX	XXX	XXX	XXX
REV N	XXX	XXX	XXX	XXX
REV O	XXX	XXX	XXX	XXX
REV P	XXX	XXX	XXX	XXX
REV Q	XXX	XXX	XXX	XXX
REV R	XXX	XXX	XXX	XXX
REV S	XXX	XXX	XXX	XXX
REV T	XXX	XXX	XXX	XXX
REV U	XXX	XXX	XXX	XXX
REV V	XXX	XXX	XXX	XXX
REV W	XXX	XXX	XXX	XXX
REV X	XXX	XXX	XXX	XXX
REV Y	XXX	XXX	XXX	XXX
REV Z	XXX	XXX	XXX	XXX
REV AA	XXX	XXX	XXX	XXX
REV AB	XXX	XXX	XXX	XXX
REV AC	XXX	XXX	XXX	XXX
REV AD	XXX	XXX	XXX	XXX
REV AE	XXX	XXX	XXX	XXX
REV AF	XXX	XXX	XXX	XXX
REV AG	XXX	XXX	XXX	XXX
REV AH	XXX	XXX	XXX	XXX
REV AI	XXX	XXX	XXX	XXX
REV AJ	XXX	XXX	XXX	XXX
REV AK	XXX	XXX	XXX	XXX
REV AL	XXX	XXX	XXX	XXX
REV AM	XXX	XXX	XXX	XXX
REV AN	XXX	XXX	XXX	XXX
REV AO	XXX	XXX	XXX	XXX
REV AP	XXX	XXX	XXX	XXX
REV AQ	XXX	XXX	XXX	XXX
REV AR	XXX	XXX	XXX	XXX
REV AS	XXX	XXX	XXX	XXX
REV AT	XXX	XXX	XXX	XXX
REV AU	XXX	XXX	XXX	XXX
REV AV	XXX	XXX	XXX	XXX
REV AW	XXX	XXX	XXX	XXX
REV AX	XXX	XXX	XXX	XXX
REV AY	XXX	XXX	XXX	XXX
REV AZ	XXX	XXX	XXX	XXX
REV BA	XXX	XXX	XXX	XXX
REV BB	XXX	XXX	XXX	XXX
REV BC	XXX	XXX	XXX	XXX
REV BD	XXX	XXX	XXX	XXX
REV BE	XXX	XXX	XXX	XXX
REV BF	XXX	XXX	XXX	XXX
REV BG	XXX	XXX	XXX	XXX
REV BH	XXX	XXX	XXX	XXX
REV BI	XXX	XXX	XXX	XXX
REV BJ	XXX	XXX	XXX	XXX
REV BK	XXX	XXX	XXX	XXX
REV BL	XXX	XXX	XXX	XXX
REV BM	XXX	XXX	XXX	XXX
REV BN	XXX	XXX	XXX	XXX
REV BO	XXX	XXX	XXX	XXX
REV BP	XXX	XXX	XXX	XXX
REV BQ	XXX	XXX	XXX	XXX
REV BR	XXX	XXX	XXX	XXX
REV BS	XXX	XXX	XXX	XXX
REV BT	XXX	XXX	XXX	XXX
REV BU	XXX	XXX	XXX	XXX
REV BV	XXX	XXX	XXX	XXX
REV BV	XXX	XXX	XXX	XXX
REV BW	XXX	XXX	XXX	XXX
REV BX	XXX	XXX	XXX	XXX
REV BY	XXX	XXX	XXX	XXX
REV BZ	XXX	XXX	XXX	XXX
REV CA	XXX	XXX	XXX	XXX
REV CB	XXX	XXX	XXX	XXX
REV CC	XXX	XXX	XXX	XXX
REV CD	XXX	XXX	XXX	XXX
REV CE	XXX	XXX	XXX	XXX
REV CF	XXX	XXX	XXX	XXX
REV CG	XXX	XXX	XXX	XXX
REV CH	XXX	XXX	XXX	XXX
REV CI	XXX	XXX	XXX	XXX
REV CJ	XXX	XXX	XXX	XXX
REV CK	XXX	XXX	XXX	XXX
REV CL	XXX	XXX	XXX	XXX
REV CM	XXX	XXX	XXX	XXX
REV CN	XXX	XXX	XXX	XXX
REV CO	XXX	XXX	XXX	XXX
REV CP	XXX	XXX	XXX	XXX
REV CQ	XXX	XXX	XXX	XXX
REV CR	XXX	XXX	XXX	XXX
REV CS	XXX	XXX	XXX	XXX
REV CT	XXX	XXX	XXX	XXX
REV CU	XXX	XXX	XXX	XXX
REV CV	XXX	XXX	XXX	XXX
REV CW	XXX	XXX	XXX	XXX
REV CX	XXX	XXX	XXX	XXX
REV CY	XXX	XXX	XXX	XXX
REV CZ	XXX	XXX	XXX	XXX
REV DA	XXX	XXX	XXX	XXX
REV DB	XXX	XXX	XXX	XXX
REV DC	XXX	XXX	XXX	XXX
REV DD	XXX	XXX	XXX	XXX
REV DE	XXX	XXX	XXX	XXX
REV DF	XXX	XXX	XXX	XXX
REV DG	XXX	XXX	XXX	XXX
REV DH	XXX	XXX	XXX	XXX
REV DI	XXX	XXX	XXX	XXX
REV DJ	XXX	XXX	XXX	XXX
REV DK	XXX	XXX	XXX	XXX
REV DL	XXX	XXX	XXX	XXX
REV DM	XXX	XXX	XXX	XXX
REV DN	XXX	XXX	XXX	XXX
REV DO	XXX	XXX	XXX	XXX
REV DP	XXX	XXX	XXX	XXX
REV DQ	XXX	XXX	XXX	XXX
REV DR	XXX	XXX	XXX	XXX
REV DS	XXX	XXX	XXX	XXX
REV DT	XXX	XXX	XXX	XXX
REV DU	XXX	XXX	XXX	XXX
REV DV	XXX	XXX	XXX	XXX
REV DW	XXX	XXX	XXX	XXX
REV DX	XXX	XXX	XXX	XXX
REV DY	XXX	XXX	XXX	XXX
REV DZ	XXX	XXX	XXX	XXX
REV EA	XXX	XXX	XXX	XXX
REV EB	XXX	XXX	XXX	XXX
REV EC	XXX	XXX	XXX	XXX
REV ED	XXX	XXX	XXX	XXX
REV EE	XXX	XXX	XXX	XXX
REV EF	XXX	XXX	XXX	XXX
REV EG	XXX	XXX	XXX	XXX
REV EH	XXX	XXX	XXX	XXX
REV EI	XXX	XXX	XXX	XXX
REV EJ	XXX	XXX	XXX	XXX
REV EK	XXX	XXX	XXX	XXX
REV EL	XXX	XXX	XXX	XXX
REV EM	XXX	XXX	XXX	XXX
REV EN	XXX	XXX	XXX	XXX
REV EO	XXX	XXX	XXX	XXX
REV EP	XXX	XXX	XXX	XXX
REV EQ	XXX	XXX	XXX	XXX
REV ER	XXX	XXX	XXX	XXX
REV ES	XXX	XXX	XXX	XXX
REV ET	XXX	XXX	XXX	XXX
REV EU	XXX	XXX	XXX	XXX
REV EV	XXX	XXX	XXX	XXX
REV EW	XXX	XXX	XXX	XXX
REV EX	XXX	XXX	XXX	XXX
REV EY	XXX	XXX	XXX	XXX
REV EZ	XXX	XXX	XXX	XXX
REV FA	XXX	XXX	XXX	XXX
REV FB	XXX	XXX	XXX	XXX
REV FC	XXX	XXX	XXX	XXX
REV FD	XXX	XXX	XXX	XXX
REV FE	XXX	XXX	XXX	XXX
REV FF	XXX	XXX	XXX	XXX
REV FG	XXX	XXX	XXX	XXX
REV FH	XXX	XXX	XXX	XXX
REV FI	XXX	XXX	XXX	XXX
REV FJ	XXX	XXX	XXX	XXX
REV FK	XXX	XXX	XXX	XXX
REV FL	XXX	XXX	XXX	XXX
REV FM	XXX	XXX	XXX	XXX
REV FN	XXX	XXX	XXX	XXX
REV FO	XXX	XXX	XXX	XXX
REV FP	XXX	XXX	XXX	XXX
REV FQ	XXX	XXX	XXX	XXX
REV FR	XXX	XXX	XXX	XXX
REV FS	XXX	XXX	XXX	XXX
REV FT	XXX	XXX	XXX	XXX
REV FU	XXX	XXX	XXX	XXX
REV FV	XXX	XXX	XXX	XXX
REV FW	XXX	XXX	XXX	XXX
REV FX	XXX	XXX	XXX	XXX
REV FY	XXX	XXX	XXX	XXX
REV FZ	XXX	XXX	XXX	XXX
REV GA	XXX	XXX	XXX	XXX
REV GB	XXX	XXX	XXX	XXX
REV GC	XXX	XXX	XXX	XXX
REV GD	XXX	XXX	XXX	XXX
REV GE	XXX	XXX	XXX	XXX
REV GF	XXX	XXX	XXX	XXX
REV GG	XXX	XXX	XXX	XXX
REV GH	XXX	XXX	XXX	XXX
REV GI	XXX	XXX	XXX	XXX
REV GJ	XXX	XXX	XXX	XXX
REV GK	XXX	XXX	XXX	XXX
REV GL	XXX	XXX	XXX	XXX
REV GM	XXX	XXX	XXX	XXX
REV GN	XXX	XXX	XXX	XXX
REV GO	XXX	XXX	XXX	XXX
REV GP	XXX	XXX	XXX	XXX
REV GQ	XXX	XXX	XXX	XXX
REV GR	XXX	XXX	XXX	XXX
REV GS	XXX	XXX	XXX	XXX
REV GT	XXX	XXX	XXX	XXX
REV GU	XXX	XXX	XXX	XXX
REV GV	XXX	XXX	XXX	XXX
REV GW	XXX	XXX	XXX	XXX
REV GX	XXX	XXX	XXX	XXX
REV GY	XXX	XXX	XXX	XXX
REV GZ	XXX	XXX	XXX	XXX
REV HA	XXX	XXX	XXX	XXX
REV HB	XXX	XXX	XXX	XXX
REV HC	XXX	XXX	XXX	XXX
REV HD	XXX	XXX	XXX	XXX
REV HE	XXX	XXX	XXX	XXX
REV HF	XXX	XXX	XXX	XXX
REV HG	XXX	XXX	XXX	XXX
REV HH	XXX	XXX	XXX	XXX
REV HI	XXX	XXX	XXX	XXX
REV HJ	XXX	XXX	XXX	XXX
REV HK	XXX	XXX	XXX	XXX
REV HL	XXX	XXX	XXX	XXX
REV HM	XXX	XXX	XXX	XXX
REV HN	XXX	XXX	XXX	XXX
REV HO	XXX	XXX	XXX	XXX
REV HP	XXX	XXX	XXX	XXX
REV HQ	XXX	XXX	XXX	XXX
REV HR	XXX	XXX	XXX	XXX
REV HS	XXX	XXX	XXX	XXX
REV HT	XXX	XXX	XXX	XXX
REV HU	XXX	XXX	XXX	XXX
REV HV	XXX	XXX	XXX	XXX
REV HW	XXX	XXX	XXX	XXX
REV HX	XXX	XXX	XXX	XXX
REV HY	XXX	XXX	XXX	XXX
REV HZ	XXX	XXX	XXX	XXX
REV IA	XXX	XXX	XXX	XXX
REV IB	XXX	XXX	XXX	XXX
REV IC	XXX	XXX	XXX	XXX
REV ID	XXX	XXX	XXX	XXX
REV IE	XXX	XXX	XXX	XXX
REV IF	XXX	XXX	XXX	XXX
REV IG	XXX	XXX	XXX	XXX
REV IH	XXX	XXX	XXX	XXX
REV II	XXX	XXX	XXX	XXX
REV IJ	XXX	XXX	XXX	XXX
REV IK	XXX	XXX	XXX	XXX
REV IL	XXX	XXX	XXX	XXX
REV IM	XXX	XXX	XXX	XXX
REV IN	XXX	XXX	XXX	XXX
REV IO	XXX	XXX	XXX	XXX
REV IP	XXX	XXX	XXX	XXX
REV IQ	XXX	XXX	XXX	XXX
REV IR	XXX	XXX	XXX	XXX
REV IS	XXX	XXX	XXX	XXX
REV IT	XXX	XXX	XXX	XXX
REV IU	XXX	XXX	XXX	XXX
REV IV	XXX	XXX	XXX	XXX
REV IW	XXX	XXX	XXX	XXX
REV IX	XXX	XXX	XXX	XXX
REV IY	XXX	XXX	XXX	XXX
REV IZ	XXX	XXX	XXX	XXX
REV JA	XXX	XXX	XXX	XXX
REV JB	XXX	XXX	XXX	XXX
REV JC	XXX	XXX	XXX	XXX
REV JD	XXX	XXX	XXX	XXX
REV JE	XXX	XXX	XXX	XXX
REV JF	XXX	XXX	XXX	XXX
REV JG	XXX	XXX	XXX	XXX
REV JH	XXX	XXX		

Figure 4-57. SAMA5D44 - SYS, PIOD, and PIOE



REV. 1	DATE	SCALE	1/1
REV. 2	DATE	SCALE	1/1
REV. 3	DATE	SCALE	1/1
REV. 4	DATE	SCALE	1/1
REV. 5	DATE	SCALE	1/1
REV. 6	DATE	SCALE	1/1
REV. 7	DATE	SCALE	1/1
REV. 8	DATE	SCALE	1/1
REV. 9	DATE	SCALE	1/1
REV. 10	DATE	SCALE	1/1
REV. 11	DATE	SCALE	1/1
REV. 12	DATE	SCALE	1/1
REV. 13	DATE	SCALE	1/1
REV. 14	DATE	SCALE	1/1
REV. 15	DATE	SCALE	1/1

Figure 4-58. JTAG, USB, DEBUG, and LCD

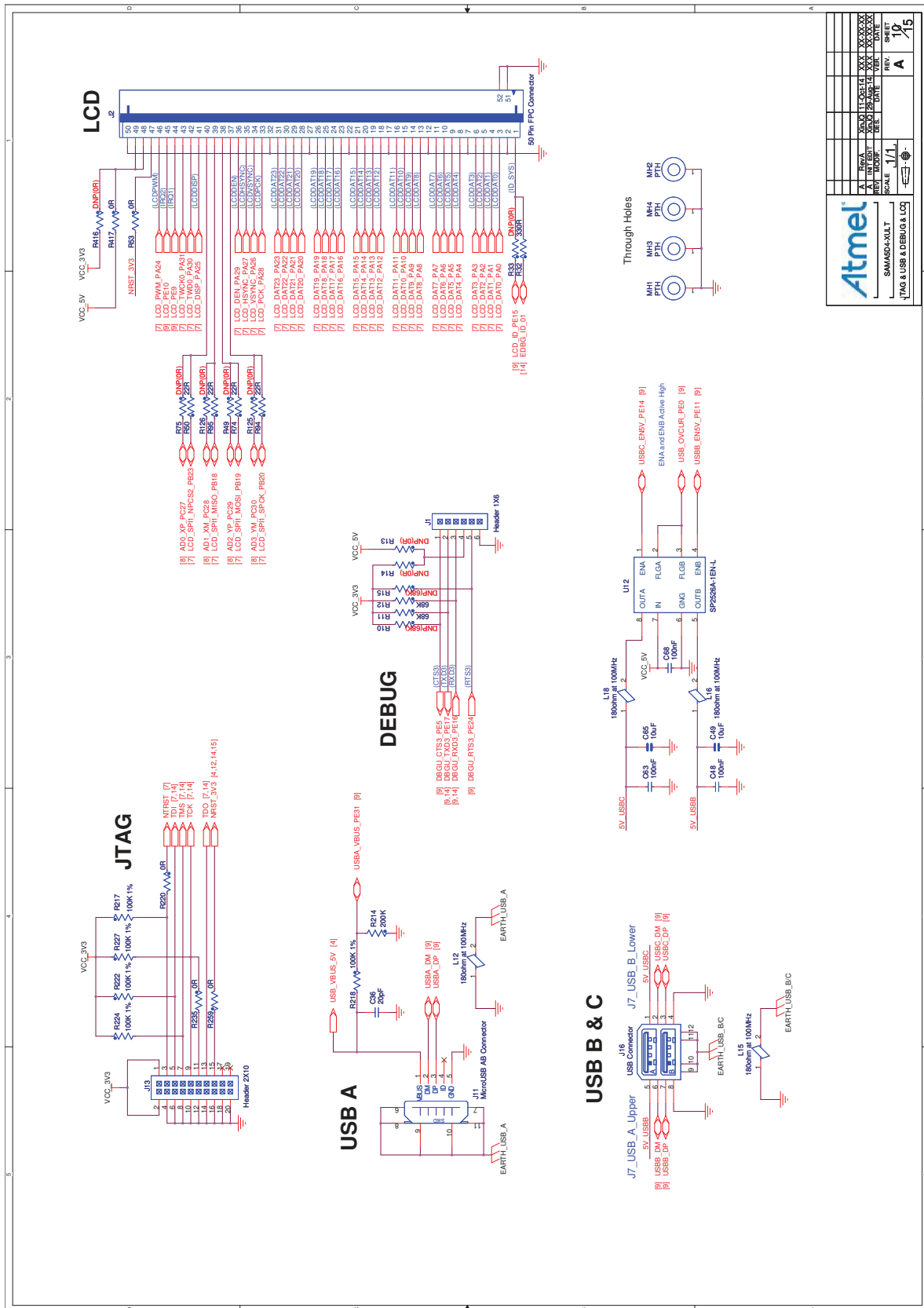

Atmel		SAMA5D4-XLLT		SCALE 1/1		SHEET 10		REV. A		15	
ATMEL		SAMA5D4-XLLT		SCALE 1/1		SHEET 10		REV. A		15	
ATMEL		SAMA5D4-XLLT		SCALE 1/1		SHEET 10		REV. A		15	

Figure 4-61. HSMCI

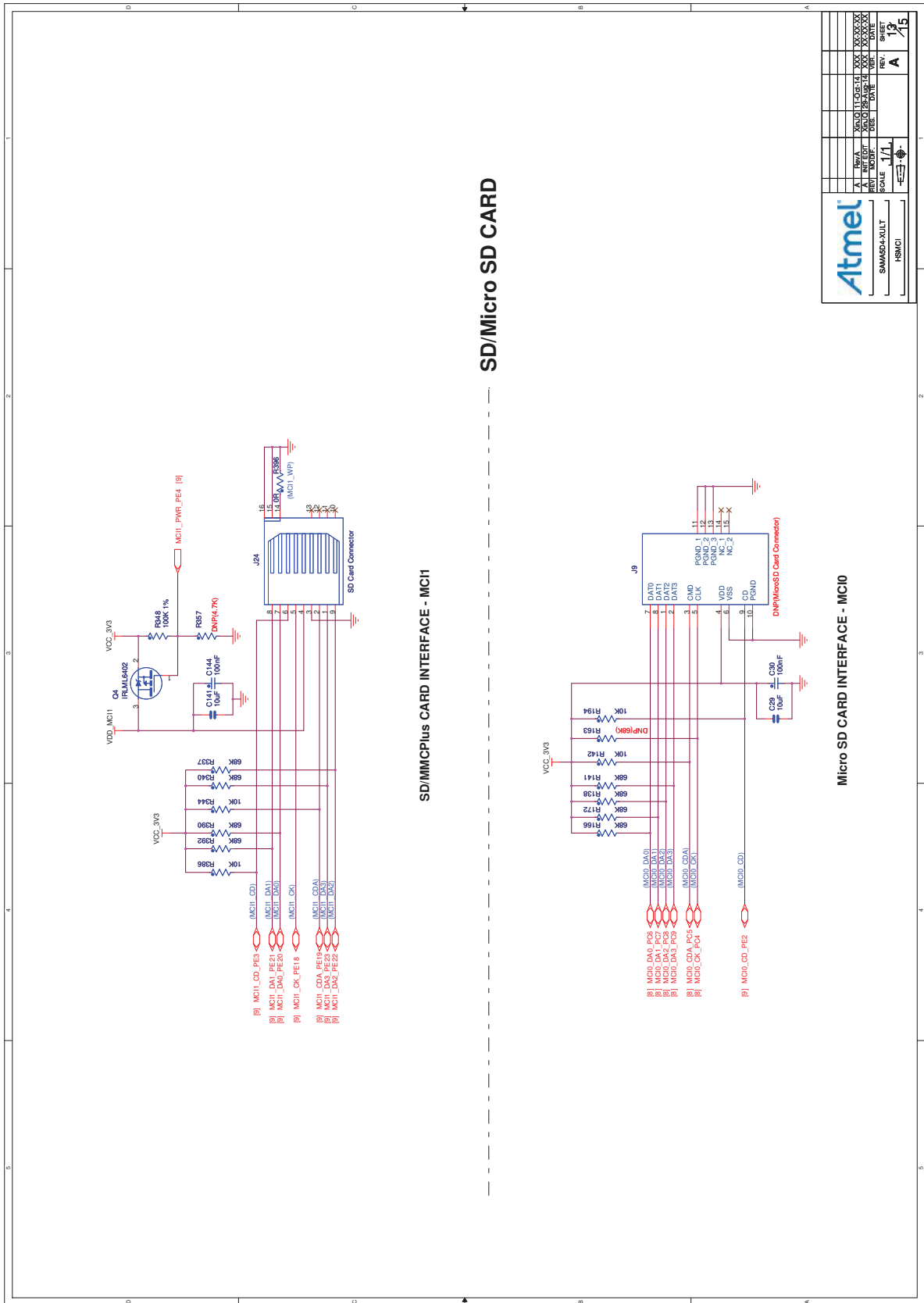

Atmel		SAMA5D4-XULT		HSMCI	
REV. A	DATE 11/11	SCALE 1/1	REV. A	SHEET 13	TOTAL 15
XXXXXXXXXX		XXXXXXXXXX		XXXXXXXXXX	
XXXXXXXXXX		XXXXXXXXXX		XXXXXXXXXX	
XXXXXXXXXX		XXXXXXXXXX		XXXXXXXXXX	

Figure 4-62. EDBG

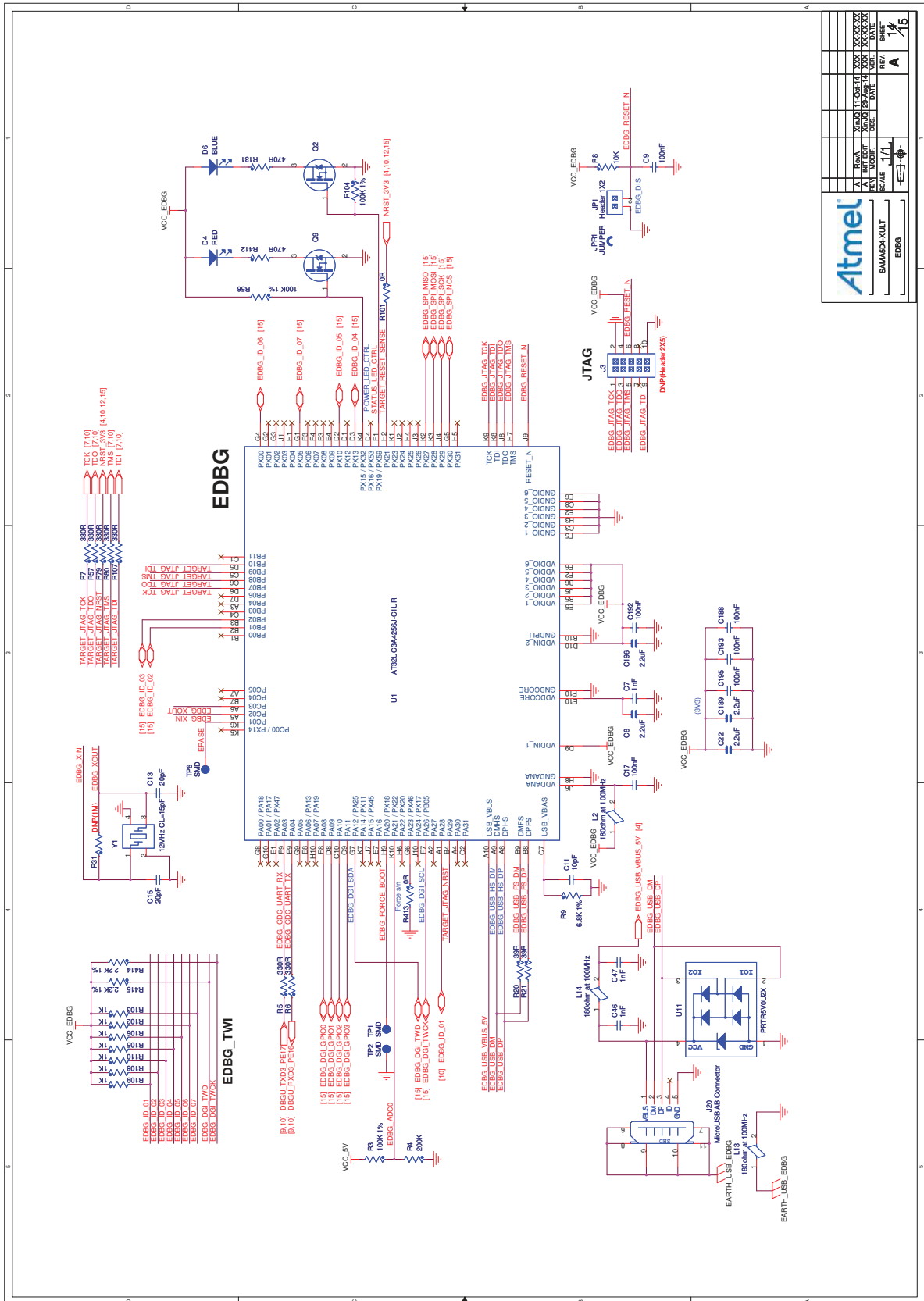

Atmel		SAMA5D4-XLLT		EDBG	
REV. A	DATE: 11/05/14	SCALE: 1/1	SHEET: A	REV. 14	15
MFG: XXXXX		REV: XXXXX		REV: XXXXX	
MFG: XXXXX		REV: XXXXX		REV: XXXXX	
MFG: XXXXX		REV: XXXXX		REV: XXXXX	
MFG: XXXXX		REV: XXXXX		REV: XXXXX	



5. Revision History

In the tables that follow, the most recent version of the document appears first.

Table 5-1. SAMA5D4 Xplained Ultra User Guide Rev. 44005C Revision History

Doc. Date	Changes
11-Aug-15	Updated Section 4.2.1 “Processor” Modified Section 4.2.2.1 “Power Lines” Modified Section 4.2.2.2 “Power-up and Power-down Considerations” (title and content)

Table 5-2. SAMA5D4 Xplained Ultra User Guide Rev. 44005B Revision History

Doc. Date	Changes
28-Feb-15	Minor formatting and editorial changes throughout Table 4-3 “DDR_CALN and DDR_CALP” : added column header “Memory Type” Section 4.2.9.3 “LCD Power” : corrected “two voltage lines are available: 3.3V by default and 5 VCC” to read “two voltage lines are available: 3.3V and 5 VCC (default)” Table 4-13 “SAMA5D44 Peripheral Functions Available through the Arduino Headers” : changed column header “SAMA5D4 to Arduino” to “SAMA5D44 to Arduino”; added column header “System Function” Table 4-20 “SD/MMC Socket J24 Signal Descriptions” : defined mnemonic for pins 15 and 16 as “VSS” Table 4-21 “MicroSD Socket J9 Signal Descriptions” : for pin 9, changed mnemonic from “CARD DETECT” to “CD”; for pin 10, changed mnemonic from “PGND” to “GND”

Table 5-3. SAMA5D4 Xplained Ultra User Guide Rev. 44005 Revision History

Doc. Rev.	Changes
44005A	First issue.



Atmel® | Enabling Unlimited Possibilities®



Atmel Corporation 1600 Technology Drive, San Jose, CA 95110 USA T: (+1)(408) 441.0311 F: (+1)(408) 436.4200 | www.atmel.com

© 2015 Atmel Corporation. / Rev.: Atmel-44005C-ATARM-SAMA5D4-Xplained-Ultra-User Guide_11-Aug-15.

Atmel®, Atmel logo and combinations thereof, Enabling Unlimited Possibilities®, maXTouch®, QTouch® and others are registered trademarks or trademarks of Atmel Corporation in U.S. and other countries. ARM®, ARM Connected® logo, and others are the registered trademarks or trademarks of ARM Ltd. Other terms and product names may be trademarks of others.

DISCLAIMER: The information in this document is provided in connection with Atmel products. No license, express or implied, by estoppel or otherwise, to any intellectual property right is granted by this document or in connection with the sale of Atmel products. EXCEPT AS SET FORTH IN THE ATMEL TERMS AND CONDITIONS OF SALES LOCATED ON THE ATMEL WEBSITE, ATMEL ASSUMES NO LIABILITY WHATSOEVER AND DISCLAIMS ANY EXPRESS, IMPLIED OR STATUTORY WARRANTY RELATING TO ITS PRODUCTS INCLUDING, BUT NOT LIMITED TO, THE IMPLIED WARRANTY OF MERCHANTABILITY, FITNESS FOR A PARTICULAR PURPOSE, OR NON-INFRINGEMENT. IN NO EVENT SHALL ATMEL BE LIABLE FOR ANY DIRECT, INDIRECT, CONSEQUENTIAL, PUNITIVE, SPECIAL OR INCIDENTAL DAMAGES (INCLUDING, WITHOUT LIMITATION, DAMAGES FOR LOSS AND PROFITS, BUSINESS INTERRUPTION, OR LOSS OF INFORMATION) ARISING OUT OF THE USE OR INABILITY TO USE THIS DOCUMENT, EVEN IF ATMEL HAS BEEN ADVISED OF THE POSSIBILITY OF SUCH DAMAGES. Atmel makes no representations or warranties with respect to the accuracy or completeness of the contents of this document and reserves the right to make changes to specifications and products descriptions at any time without notice. Atmel does not make any commitment to update the information contained herein. Unless specifically provided otherwise, Atmel products are not suitable for, and shall not be used in, automotive applications. Atmel products are not intended, authorized, or warranted for use as components in applications intended to support or sustain life.

SAFETY-CRITICAL, MILITARY, AND AUTOMOTIVE APPLICATIONS DISCLAIMER: Atmel products are not designed for and will not be used in connection with any applications where the failure of such products would reasonably be expected to result in significant personal injury or death ("Safety-Critical Applications") without an Atmel officer's specific written consent. Safety-Critical Applications include, without limitation, life support devices and systems, equipment or systems for the operation of nuclear facilities and weapons systems. Atmel products are not designed nor intended for use in military or aerospace applications or environments unless specifically designated by Atmel as military-grade. Atmel products are not designed nor intended for use in automotive applications unless specifically designated by Atmel as automotive-grade.