

Product Specification

NHD-5.0-800480TF-ASXN

TFT Liquid Crystal Display

NHD -	Newhaven Display
5.0-	5.0" Diagonal
800480-	800xRGBx480 Pixels
TF-	Model
A-	Built-In Driver / No Controller
S-	Sunlight Readable
X-	TFT
N-	MVA, Enhanced Optical Characteristics, Wide Temperature

Table of Contents

Document Revision History	2
Functions and Features	2
Mechanical Drawing	3
Pin Description	4
Electrical Characteristics	5
Optical Characteristics	5
Driver Information	5
Timing Characteristics for TFT	6
Quality Information	10

Additional Resources

- **Support Forum:** <http://www.nhdforum.newhavendisplay.com>
- **Github:** <https://github.com/newhavendisplay>
- **Example Code:** https://www.newhavendisplay.com/example_code.html
- **Knowledge Center:** https://www.newhavendisplay.com/knowledge_center.html
- **Quality Center:** https://www.newhavendisplay.com/quality_center.html
- **Precautions for using LCDs/LCMs:** <https://www.newhavendisplay.com/specs/precautions.pdf>
- **Warranty / Terms & Conditions:** <https://www.newhavendisplay.com/terms.html>



Document Revision History

Revision	Date	Description	Changed By
0	11/2/20	Initial Release	AS

Functions and Features

- **800xRGBx480 resolution, up to 16.7M colors**
- **27-LED backlight**
- **24 bit RGB interface**
- **Sunlight Readable**
- **Enhanced Optical Characteristics**
- **Wide Viewing Angles**

Mechanical Drawing

SYMBOL	REVISION	DATE

NO.	PIN NAME
1	VLED-
2	VLED+
3	GND
4	VDD
5	RO
6	R1
7	R2
8	R3
9	R4
10	R5
11	R6
12	R7
13	G0
14	G1
15	G2
16	G3
17	G4
18	G5
19	G6
20	G7
21	B0
22	B1
23	B2
24	B3
25	B4
26	B5
27	B6
28	B7
29	GND
30	CLKIN
31	STBYB
32	HSD
33	VSD
34	DEN
35	NC
36	GND
37	NC(XR)
38	NC(YD)
39	NC(XL)
40	NC(YU)

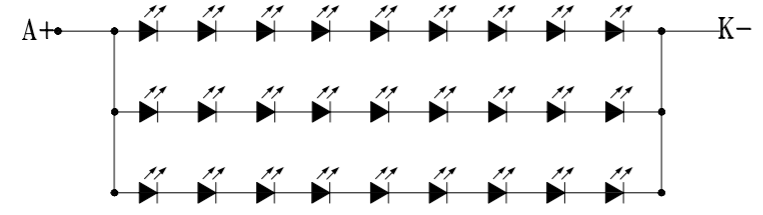
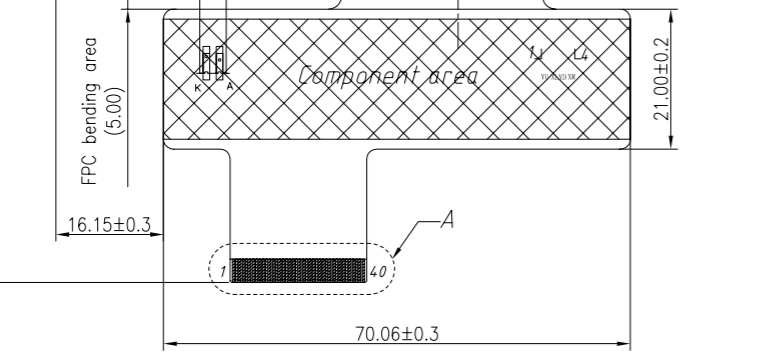
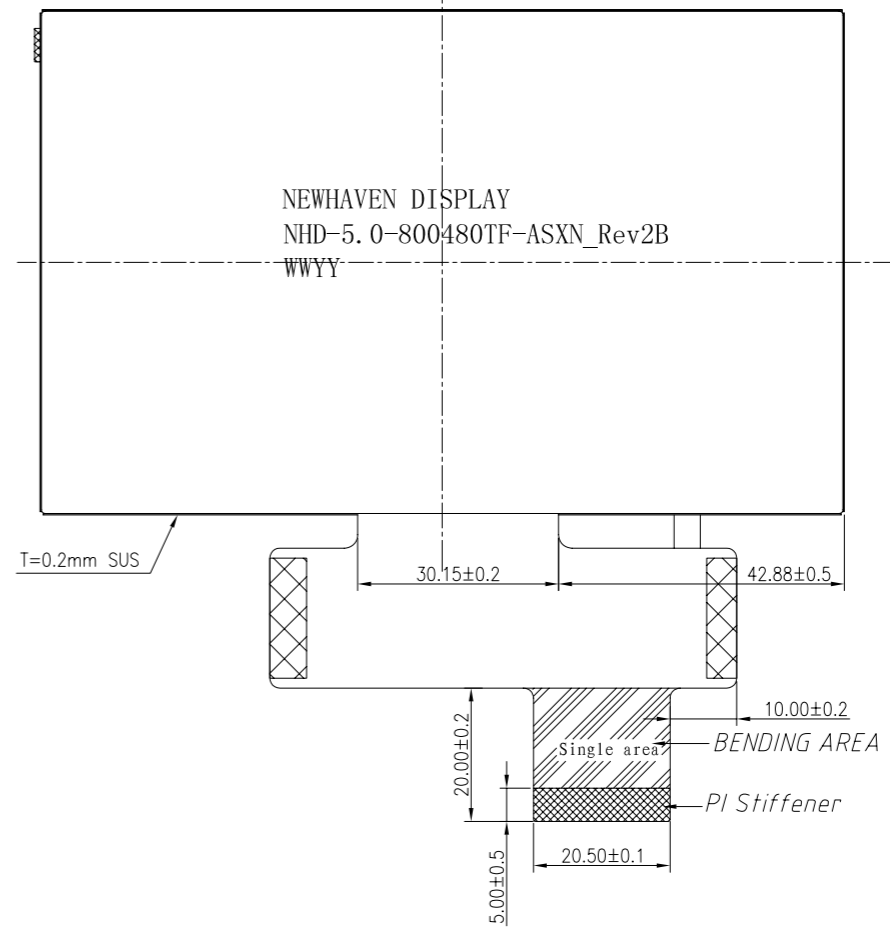
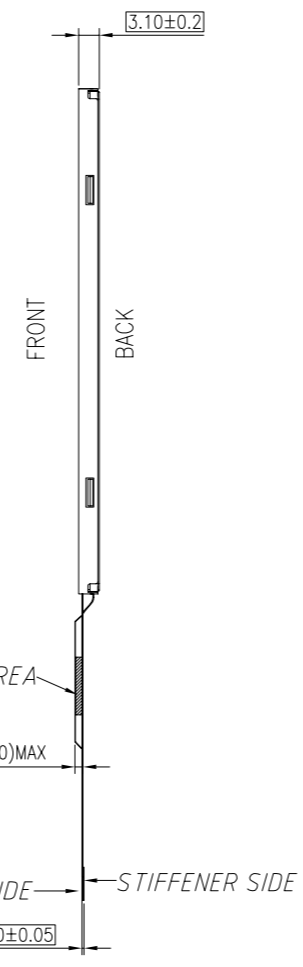
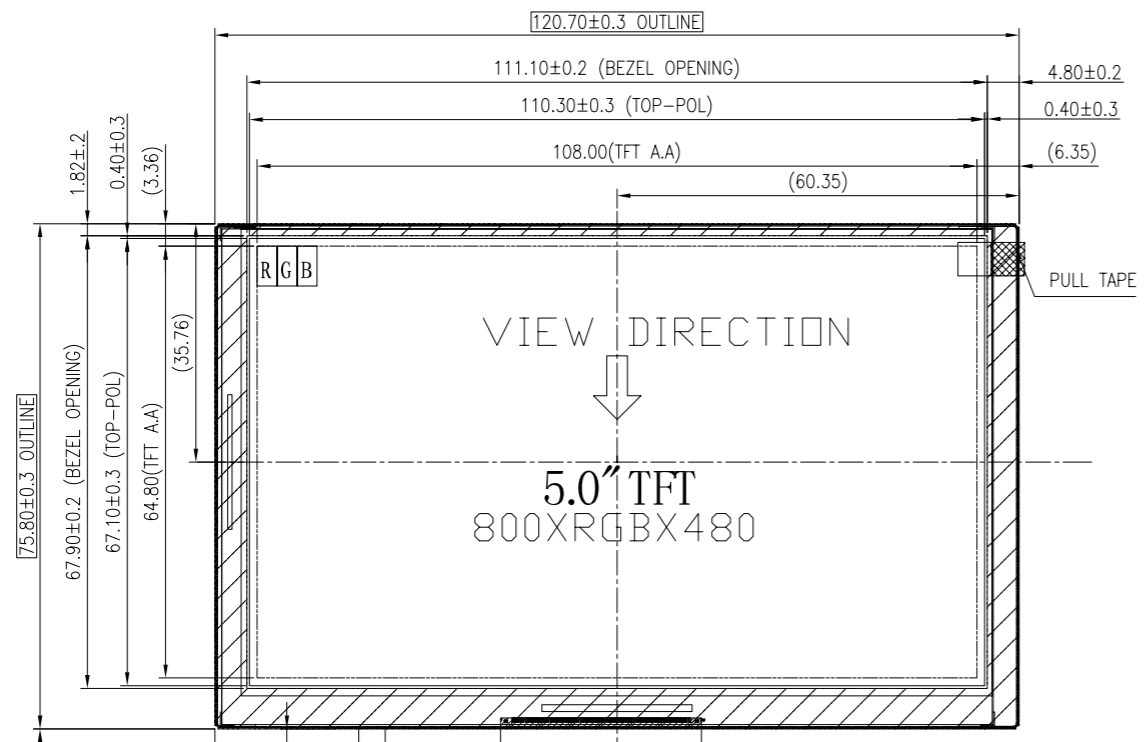

WHITE LED 60mA/27.0V(TYP)
LED CIRCUIT DIAGRAM:

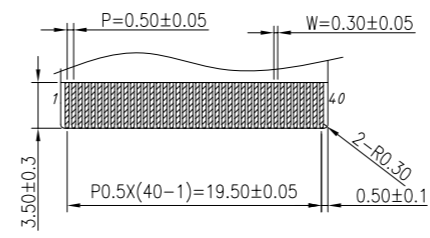

A Detail

- Notes:
- 1) Display Size: 5" Diagonal, 800 x 480 Pixels
 - 2) Display Mode: MVA / Transmissive / Normally White / Anti-Glare
 - 3) Driver IC: ILI6122
 - 4) LCD Voltage: 3.3V (TYP)
 - 5) Backlight: White LED / 60mA (TYP) / 27V (TYP)
 - 6) Luminance: 1000 cd/m²
 - 7) Operating Temperature: -20°C to 70°C
 - 8) Storage Temperature: -30°C to 80°C

Standard Tolerance: (Unless otherwise specified) Linear: ±0.3mm		
	Drawing/Part Number: NHD-5.0-800480TF-ASXN	Revision: 2B
Unless otherwise specified: • Dimensions are in Millimeters • Third Angle Projection	Drawn By: A. Shah	Approved By: A. Shah
	Drawn Date: 11/2/2020	Approved Date: 11/2/2020
Do Not Scale Drawing		Sheet 1 of 1
This drawing is solely the property of Newhaven Display International, Inc. The information it contains is not to be disclosed, reproduced or copied in whole or part without written approval from Newhaven Display.		

Pin Description

Pin No.	Symbol	External Connection	Function Description
1	LED-	LED Power Supply	Ground for Backlight
2	LED+	LED Power Supply	Backlight Power Supply (60mA @ 27V)
3	GND	Power Supply	Ground
4	V _{DD}	Power Supply	Power supply for LCD and logic (3.3V)
5-12	[R0-R7]	MPU	Red Data Signals
13-20	[G0-G7]	MPU	Green Data Signals
21-28	[B0-B7]	MPU	Blue Data Signals
29	GND	Power Supply	Ground
30	CLKIN	MPU	Clock for input data (Rising Edge)
31	STBYB	MPU	1: Normal Operation;0: Standby Mode
32	HSD	MPU	Line synchronization signal
33	VSD	MPU	Frame synchronization signal
34	DEN	MPU	Data Enable signal
35	NC	-	No Connect
36	GND	Power Supply	Ground
37	XR	-	No Connect
38	YD	-	No Connect
39	XL	-	No Connect
40	YU	-	No Connect

Recommended LCD connector: 0.5mm pitch 40-Conductor FFC. Molex p/n: 54104-4031 (top contact)

Backlight connector: on LCD connector

Mates with: ---

The ILI6122 driver IC is configured for DE Mode by default which eliminates the need to depend on HSD and VSD timing signals. Using DE mode in place of Sync mode, the display will no longer be affected by changes to the sync timing or porch settings in the event of a driver IC change. This will maintain a consistent display performance for any driver IC changes that may occur in the future.

The ILI6122 driver will treat the data on the Dx[7:0] RGB data bus as active display data while DEN is at “H” level and ignore the data on the Dx[7:0] RGB data bus while DEN is at “L” level.

Sync Mode can still be provided as the default setting but will need to be ordered as a custom option.

Electrical Characteristics

Item	Symbol	Condition	Min.	Typ.	Max.	Unit
Operating Temperature Range	T _{OP}	Absolute Max	-20	-	+70	°C
Storage Temperature Range	T _{ST}	Absolute Max	-30	-	+80	°C
Supply Voltage	V _{DD}	-	3.0	3.3	3.6	V
Supply Current	I _{DD}	V _{DD} = 3.3V	43	85	130	mA
"H" Level input	V _{IH}	-	0.7 * V _{DD}	-	V _{DD}	V
"L" Level input	V _{IL}	-	GND	-	0.3 * V _{DD}	V
"H" Level output	V _{OH}	-	V _{DD} - 0.4	-	V _{DD}	V
"L" Level output	V _{OL}	-	GND	-	GND + 0.4	V
Backlight Supply Current	I _{LED}	-	-	60	75	mA
Backlight Supply Voltage	V _{LED}	I _{LED} = 60mA	25.2	27.0	30.6	V
Backlight Lifetime*	-	T _{OP} = 25°C	30,000	-	-	Hrs.

*Backlight lifetime is rated as Hours until **half-brightness**, under normal operating conditions. The LED of the backlight is driven by current drain; drive voltage is for reference only. Drive voltage must be selected to ensure backlight current drain is below MAX level stated.

Optical Characteristics:

Item	Symbol	Condition	Min.	Typ.	Max.	Unit	
Optimal Viewing Angles	Top	φY+	-	70	-	°	
	Bottom	φY-	-	70	-	°	
	Left	θX-	-	70	-	°	
	Right	θX+	-	70	-	°	
Contrast Ratio	CR	-	400	500	-	-	
Luminance	L _V	I _{LED} = 60 mA	800	1000	-	cd/m ²	
Response Time (Rise + Fall)	T _R + T _F	T _{OP} = 25°C	-	30	40	ms	
Chromaticity	Red	X _R	-	0.530	0.570	0.610	-
		Y _R	-	0.275	0.315	0.355	-
	Green	X _G	-	0.321	0.361	0.401	-
		Y _G	-	0.546	0.586	0.626	-
	Blue	X _B	-	0.105	0.145	0.185	-
		Y _B	-	0.054	0.094	0.134	-
	White	X _W	-	0.275	0.315	0.355	-
		Y _W	-	0.287	0.327	0.355	-

Driver Information

Built-in ILI6122 Source Driver: <https://www.newhavendisplay.com/appnotes/datasheets/LCDs/ILI6122.pdf>

Built-in ILI5960D Gate Driver: <http://www.newhavendisplay.com/appnotes/datasheets/LCDs/ILI5960D.pdf>



Timing Characteristics – TFT Display

Horizontal Input Timing

Parameter	Symbol	Value			Unit	Note
Horizontal Display Area	thd	800			MHz	
DCLK Frequency	fclk	Min	Typ	Max	MHz	
		-	33.3	50		
1 Horizontal Line	th	862	1056	1200	DCLK	
HSD Pulse Width	thpw	1	-	40		
HSD Back Porch (Blanking)	thb	46	46	46		
HSD Front Porch	thfp	16	210	354		

Vertical Input Timing

Parameter	Symbol	Min	Typ	Max	Unit	Note
Vertical Display Area	tvd	480			H	
VSD Period Tim	tv	510	525	650		
VSD Pulse Width	tvpw	1	-	20		
VSD Back Porch (Blanking)	tvb	23	23	23		
VSD Front Porch	tvfp	7	22	147		

AC Characteristics

Parameter	Symbol	Min	Typ	Max	Unit	Conditions
V _{DD} Power ON Slew Rate	T _{POR}	-	-	20	ms	From 0V to 90% V _{DD}
RSTB Pulse Width	T _{RST}	10	-	-	μs	CLKIN = 50MHz
CLKIN cycle time	T _{cph}	20	-	-	ns	
CLKIN pulse duty	T _{cwh}	40	50	60	%	
VSD setup time	T _{vst}	8	-	-	ns	
VSD hold time	T _{vhd}	8	-	-	ns	
HSD setup time	T _{hst}	8	-	-	ns	
HSD hold time	T _{hhd}	8	-	-	ns	
Data set-up time	T _{dsu}	8	-	-	ns	D0R[7:0], D1G[7:0], D2B[7:0] to CLKIN
Data hold time	T _{dhd}	8	-	-	ns	D0R[7:0], D1G[7:0], D2B[7:0] to CLKIN
DE setup time	T _{esu}	8	-	-	ns	
DE hold time	T _{ehd}	8	-	-	ns	
Output stable time	T _{sst}	-	-	6	μs	10%-90% target voltage C _L = 120pf, R = 10kΩ

Parallel 24-Bit RGB Mode Timing

Parameter	Symbol	Min	Typ	Max	Unit	Conditions
CLKIN Frequency	F _{clk}	-	40	50	MHz	V _{DD} = 3.0V ~ 3.6V
CLKIN time	T _{clk}	20	25	-	Ns	
CLKIN Pulse Duty	T _{cwh}	40	50	60	%	T _{clk}
Time from HSD to Source Output	T _{hso}	-	20	-	CLKIN	
Time from HSD to LD	T _{hld}	-	20	-	CLKIN	
Time from HSD to STV	T _{hstv}	-	2	-	CLKIN	
Time from HSD to CKV	T _{hckv}	-	20	-	CLKIN	
Time from HSD to OEV	T _{hoev}	-	4	-	CLKIN	
LD Pulse Width	T _{wld}	-	10	-	CLKIN	
CKV Pulse Width	T _{wckv}	-	66	-	CLKIN	
OEV Pulse Width	T _{woev}	-	74	-	CLKIN	



Vertical Input Timing

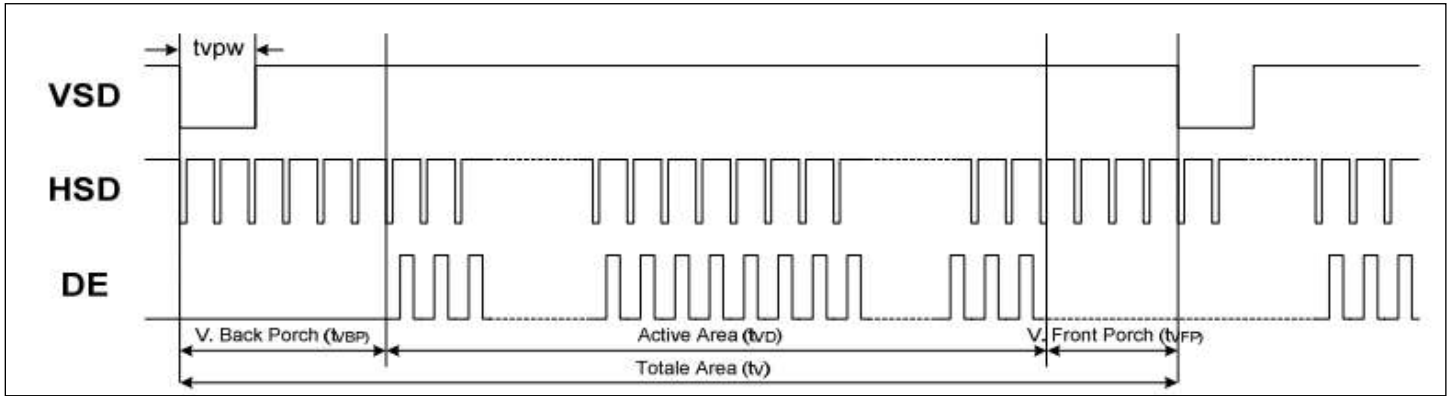

Horizontal Input Timing

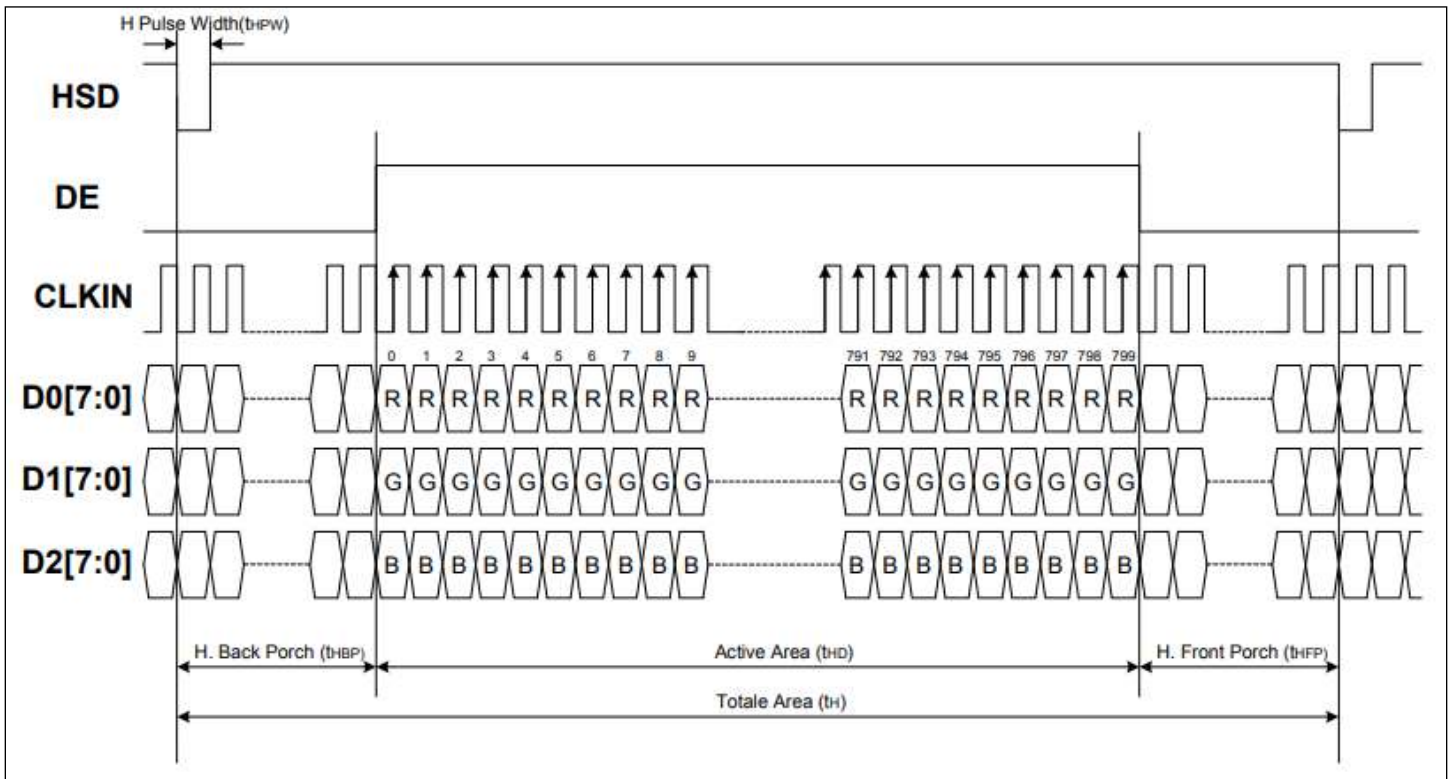

Input Clock and Data Timing

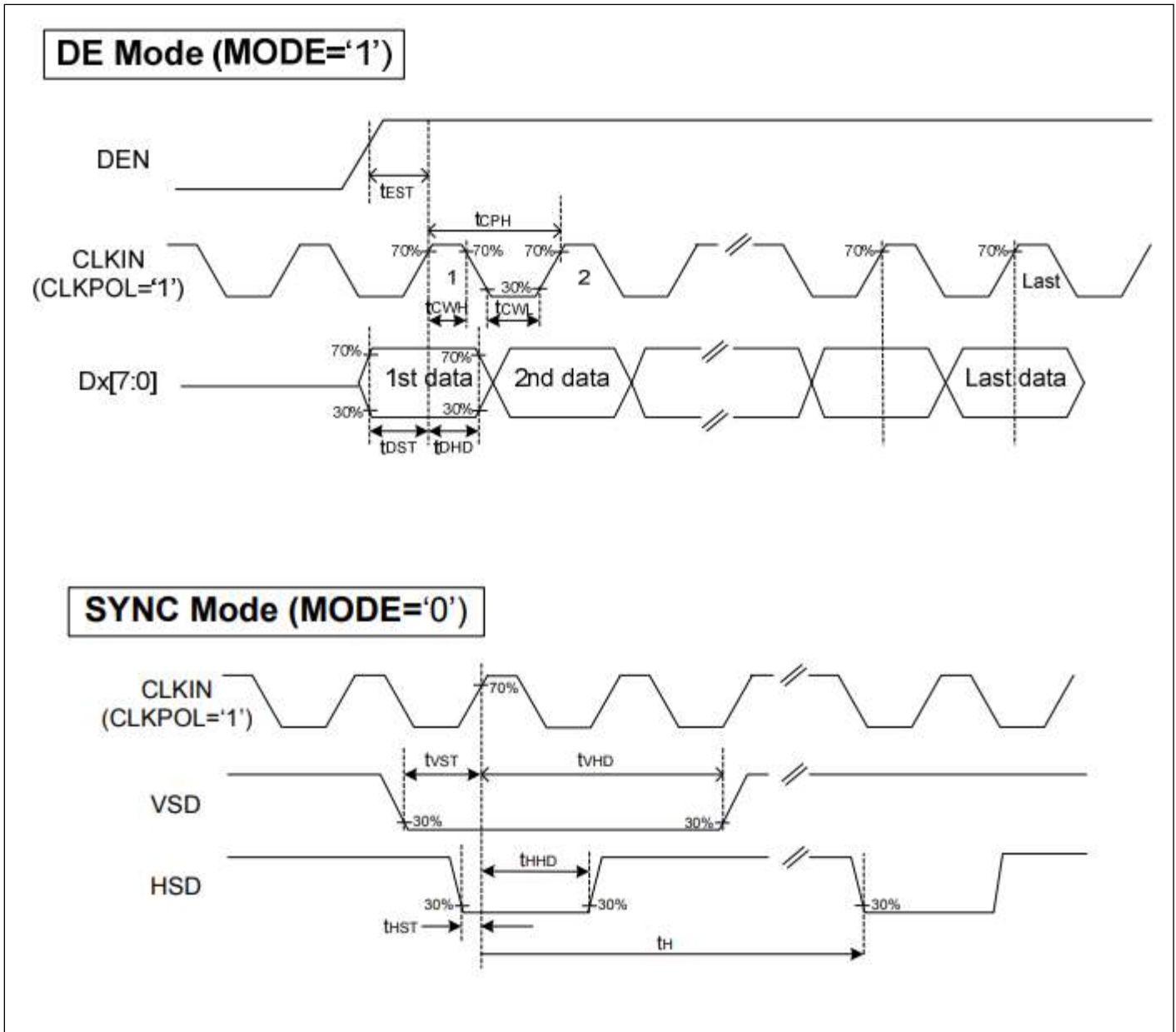

Source Output Timing

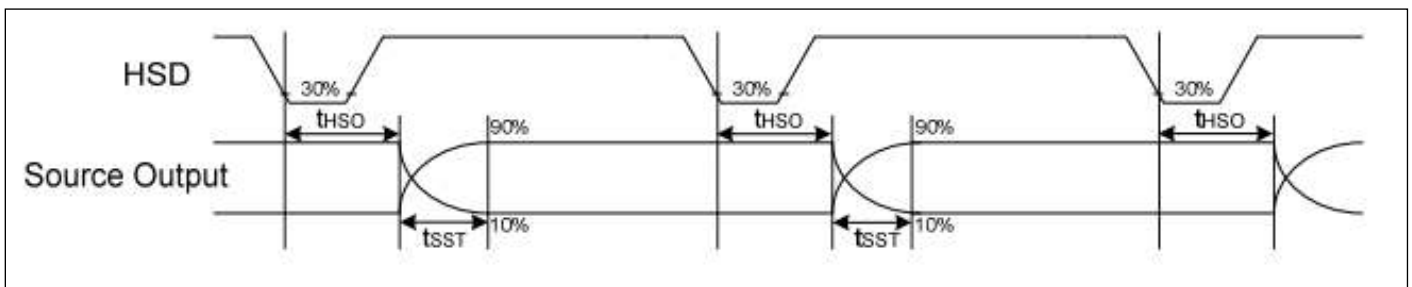

Power ON/OFF Sequence

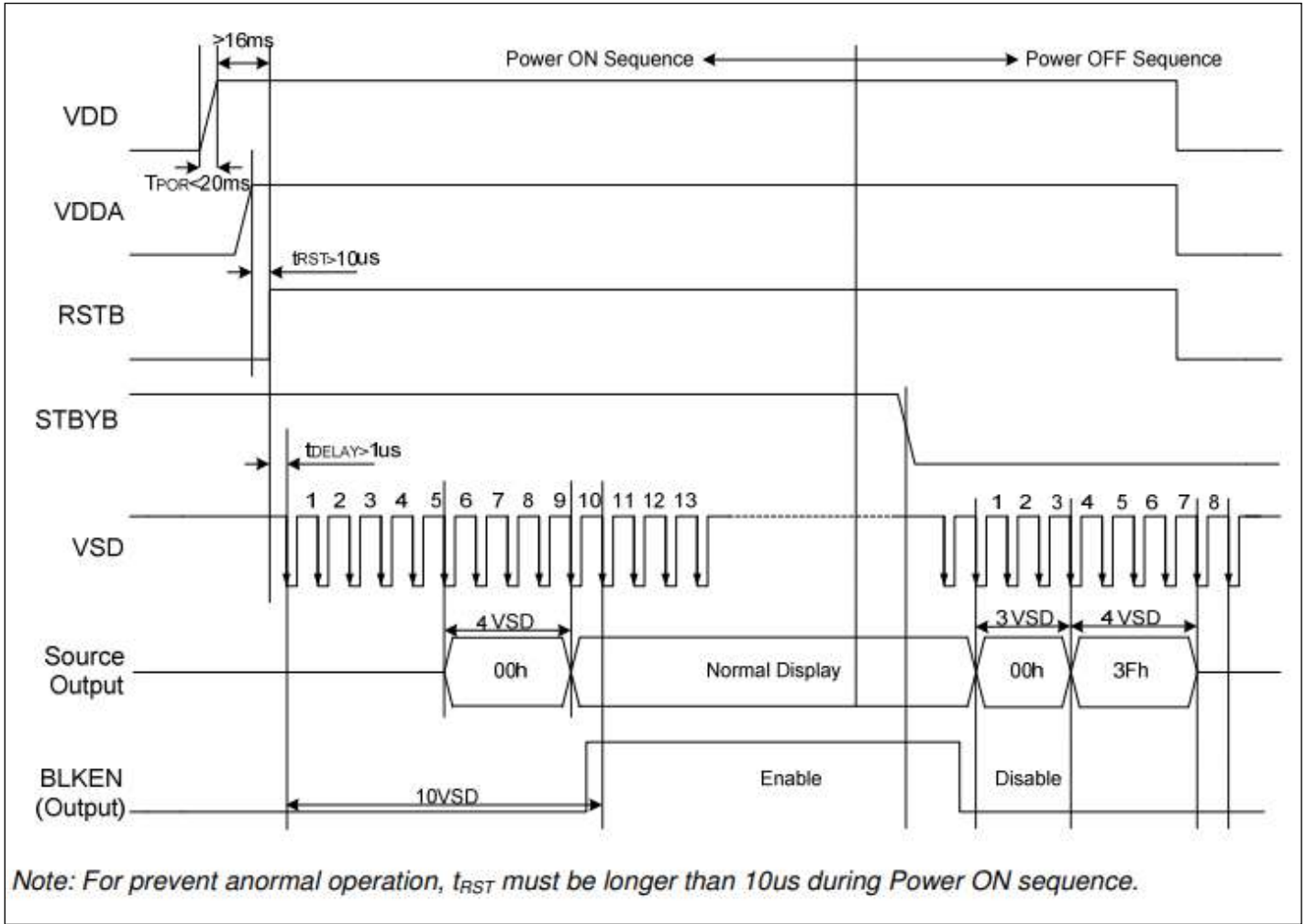

Enter/Exit Standby Mode Sequence

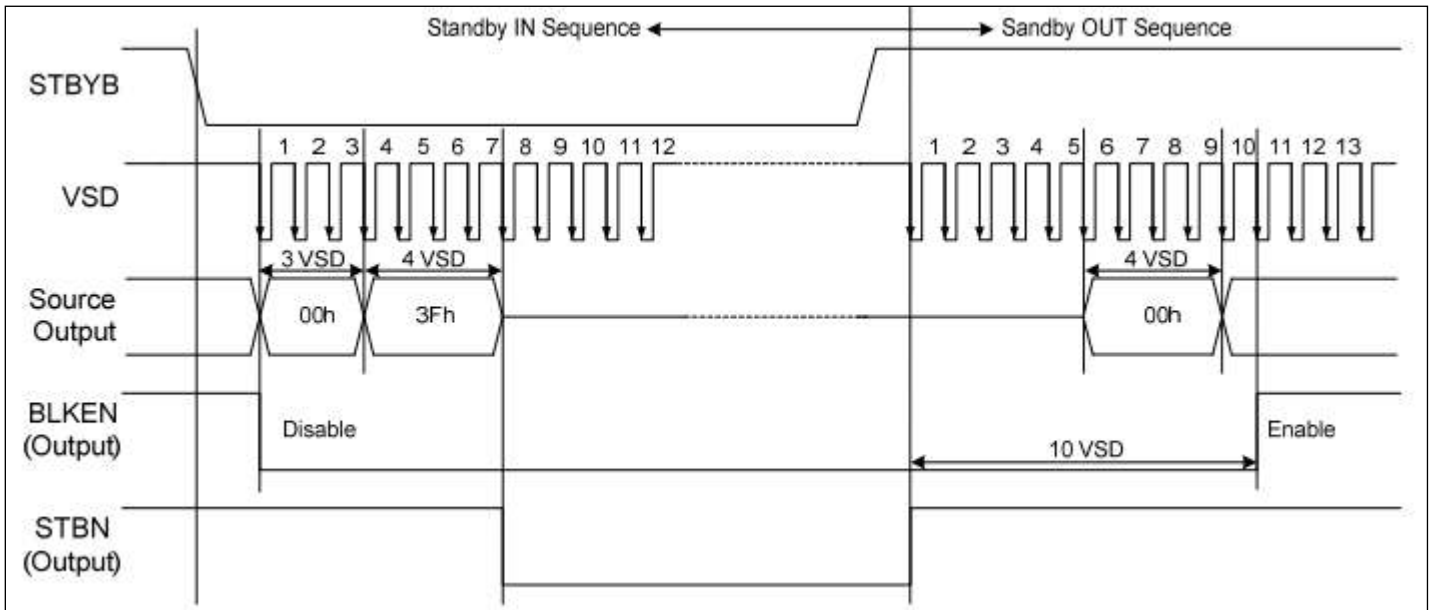

Quality Information

Test Item	Content of Test	Test Condition	Note
High Temperature storage	Endurance test applying the high storage temperature for a long time.	+80°C , 96hrs	2
Low Temperature storage	Endurance test applying the low storage temperature for a long time.	-30°C , 96hrs	1,2
High Temperature Operation	Endurance test applying the electric stress (voltage & current) and the high thermal stress for a long time.	+70°C 96hrs	2
Low Temperature Operation	Endurance test applying the electric stress (voltage & current) and the low thermal stress for a long time.	-20°C , 96hrs	1,2
High Temperature / Humidity Operation	Endurance test applying the electric stress (voltage & current) and the high thermal with high humidity stress for a long time.	+60°C , 90-95% RH , 96hrs	1,2
Thermal Shock resistance	Endurance test applying the electric stress (voltage & current) during a cycle of low and high thermal stress.	-20°C,30min -> 25°C,5min - >70°C,30min = 1 cycle 10 cycles	
Vibration test	Endurance test applying vibration to simulate transportation and use.	10-55Hz , 1.5mm amplitude, 5G Acceleration, 60 sec in each of 3 directions X,Y,Z for 2 hours	3
Static electricity test	Endurance test applying electric static discharge.	Air: ±8kV ; Contact: ±4kV For 5 times each.	

Note 1: No condensation to be observed.

Note 2: Conducted after 4 hours of storage at 25°C, 0%RH.

Note 3: Test performed on product itself, not inside a container.