

REVISIONS				
P	LTN	DESCRIPTION	DATE	APPV
H8		REV PER ECO-19-009419	19JUN2019	DS DS
H9		REV PER ECO-20-004256	25MAR2020	JM DS
H10		REVISED PER PCN E-20-016603	24NOV2020	PN DS
J		REVISED PER ECR-22-153179	18OCT2022	DK CB

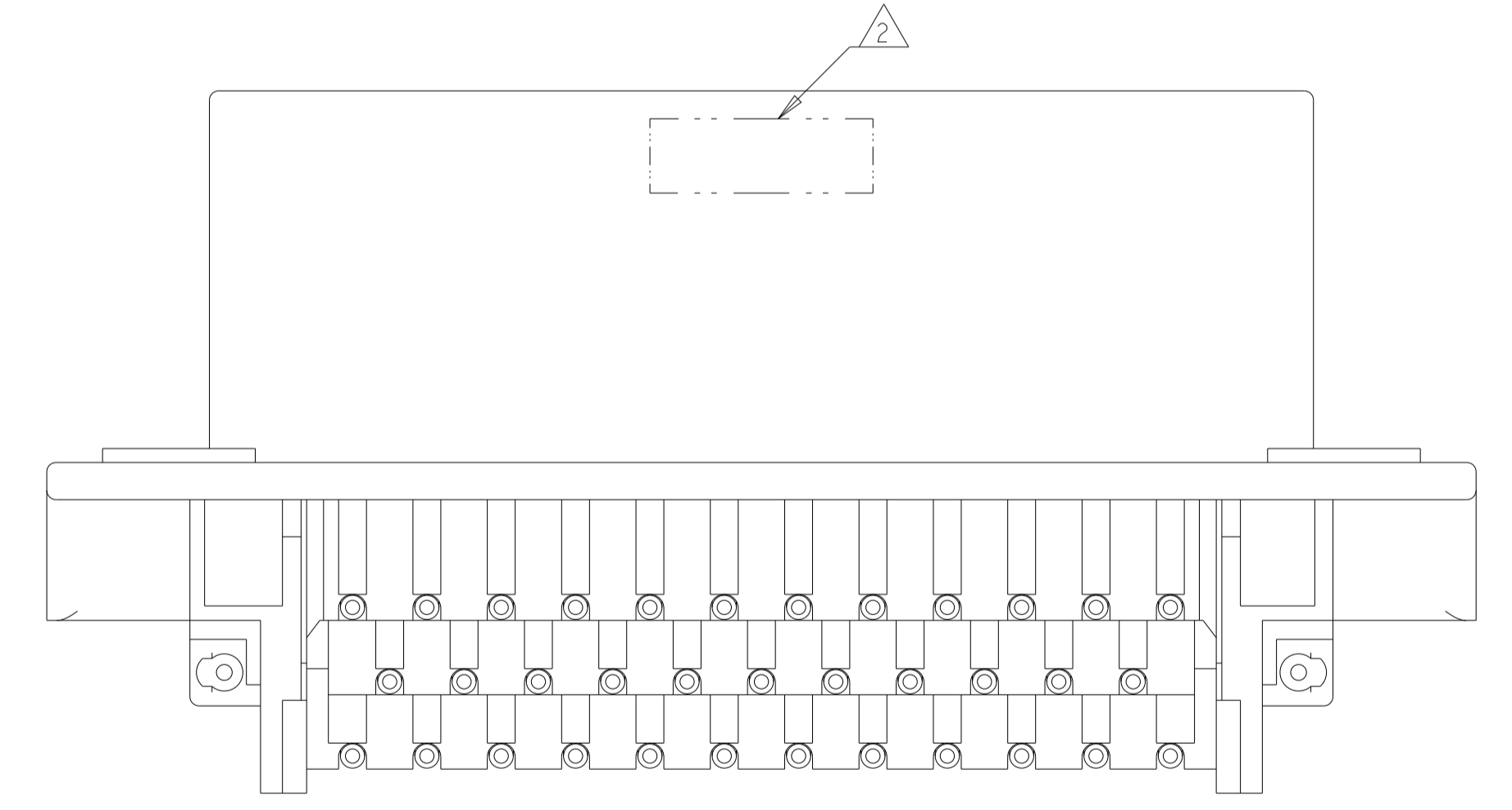
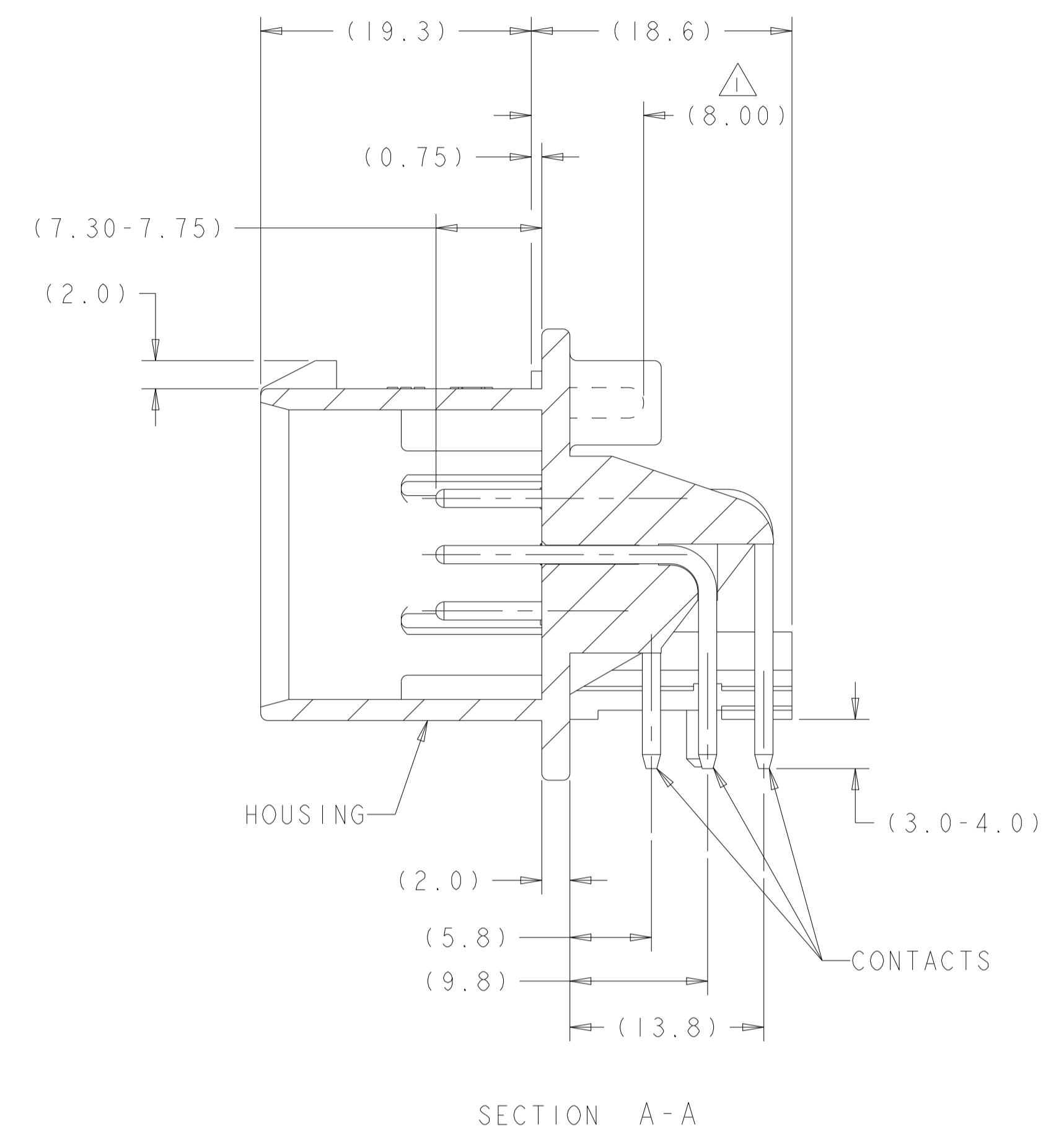
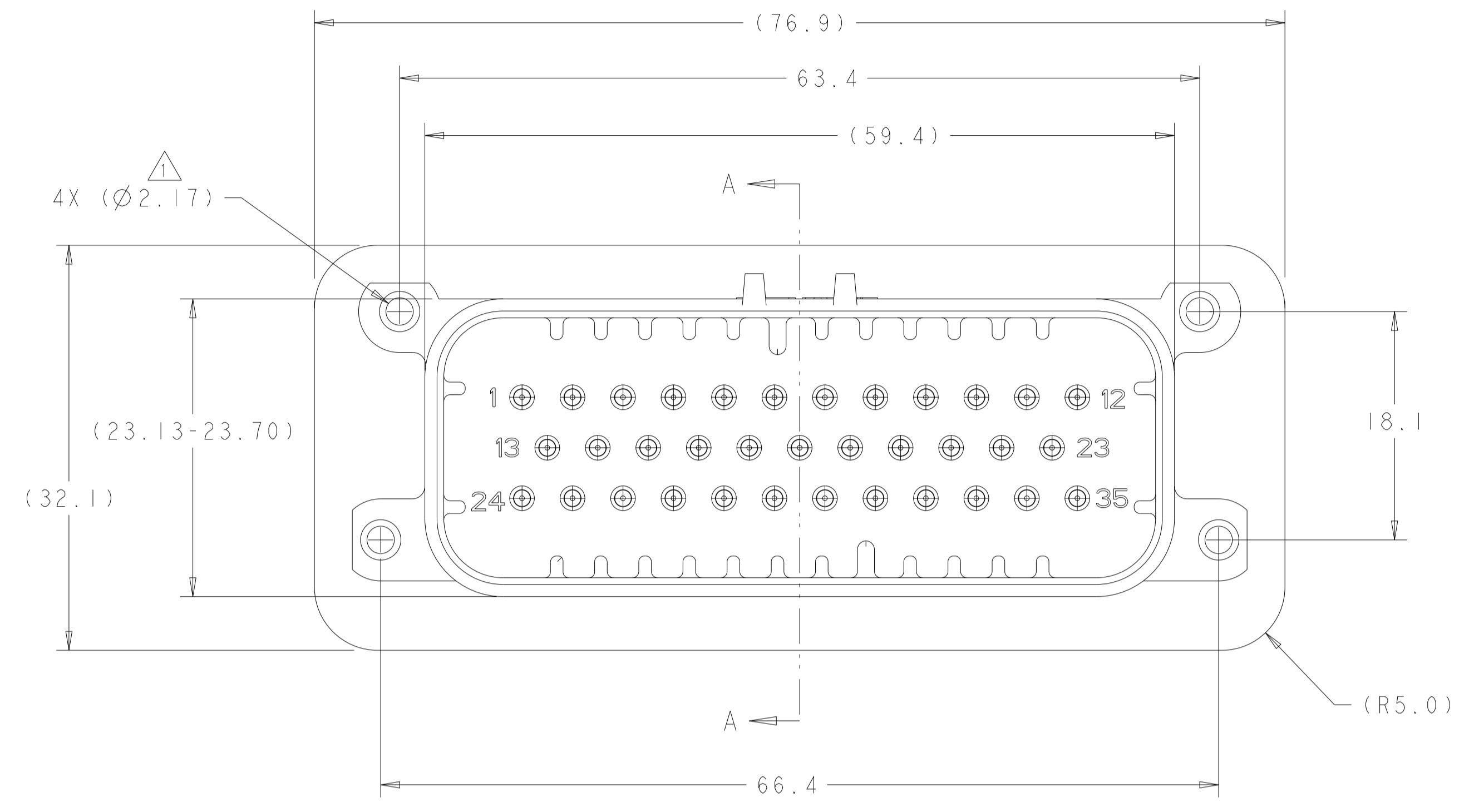

- 1 SUGGESTED MOUNTING SCREW SIZE IS  $\varnothing 2.50-3.00\text{mm}$  [ $\varnothing 0.099 - 0.118$  INCH] SELF TAPPING THREAD FORMING SCREW, SUCH AS DELTA PT, TO BE DRIVEN AT 0.6-0.8 N-m. THE CUSTOMER SHOULD TEST THE SCREW SIZE AND TYPE IN ORDER TO VERIFY THEIR SELECTION FOR THEIR APPLICATION
- 2 DATE CODE IN THIS LOCATION USING 5 DIGIT CODE. FIRST 2 DIGITS = YEAR, SECOND 2 DIGITS = WEEK, LAST DIGIT = DAY
- 3 HOUSING COLORS ARE MECHANICALLY KEYED TO MATE ONLY WITH IDENTICALLY COLORED PLUG ASSEMBLIES.
- 4 MATERIAL: HEADER HOUSING - GLASS FILLED PBT; PINS - TIN OR GOLD PLATED BRASS
- 5. HEADER MATES TO PLUG ASSEMBLY 776164 WHICH USES REELED TERMINAL 770520 OR LOOSE PIECE TERMINAL 770854

776180-1 & 1-776180-1  
 KEY LOCATION AS SHOWN

GOLD	ORANGE	1-776180-6
GOLD	BLUE	1-776180-5
GOLD	GRAY	1-776180-4
GOLD	NATURAL (WHITE)	1-776180-2
GOLD	BLACK	1-776180-1
TIN	BLUE	776180-5
TIN	GRAY	776180-4
TIN	NATURAL (WHITE)	776180-2
TIN	BLACK	776180-1
FINISH	HEADER COLOR	PART NUMBER

THIS DRAWING IS A CONTROLLED DOCUMENT.		OWN: R. VESTAL 31DEC2002	NAME: HEADER ASSEMBLY, 35 POSITION, RIGHT ANGLE, AMPSEAL	
DIMENSIONS: mm		CHK: D. CROWE 31DEC2002	RESTRICTED TO: -	
TOLERANCES UNLESS OTHERWISE SPECIFIED:		APPV: D. CROWE 31DEC2002	SCALE: 4:1	
0 PLC	±	PRODUCT SPEC	SHEET 1 OF 2	
1 PLC	±0.2	108-1329	REV J	
2 PLC	±	APPLICATION SPEC		
3 PLC	±	114-16016		
4 PLC	±	WEIGHT 40.45g		
ANGLES	±	CUSTOMER DRAWING		
FINISH	±			

REVISIONS				
P.	LTH	DESCRIPTION	DATE	APVD
-	-	SEE SHEET 1	-	-

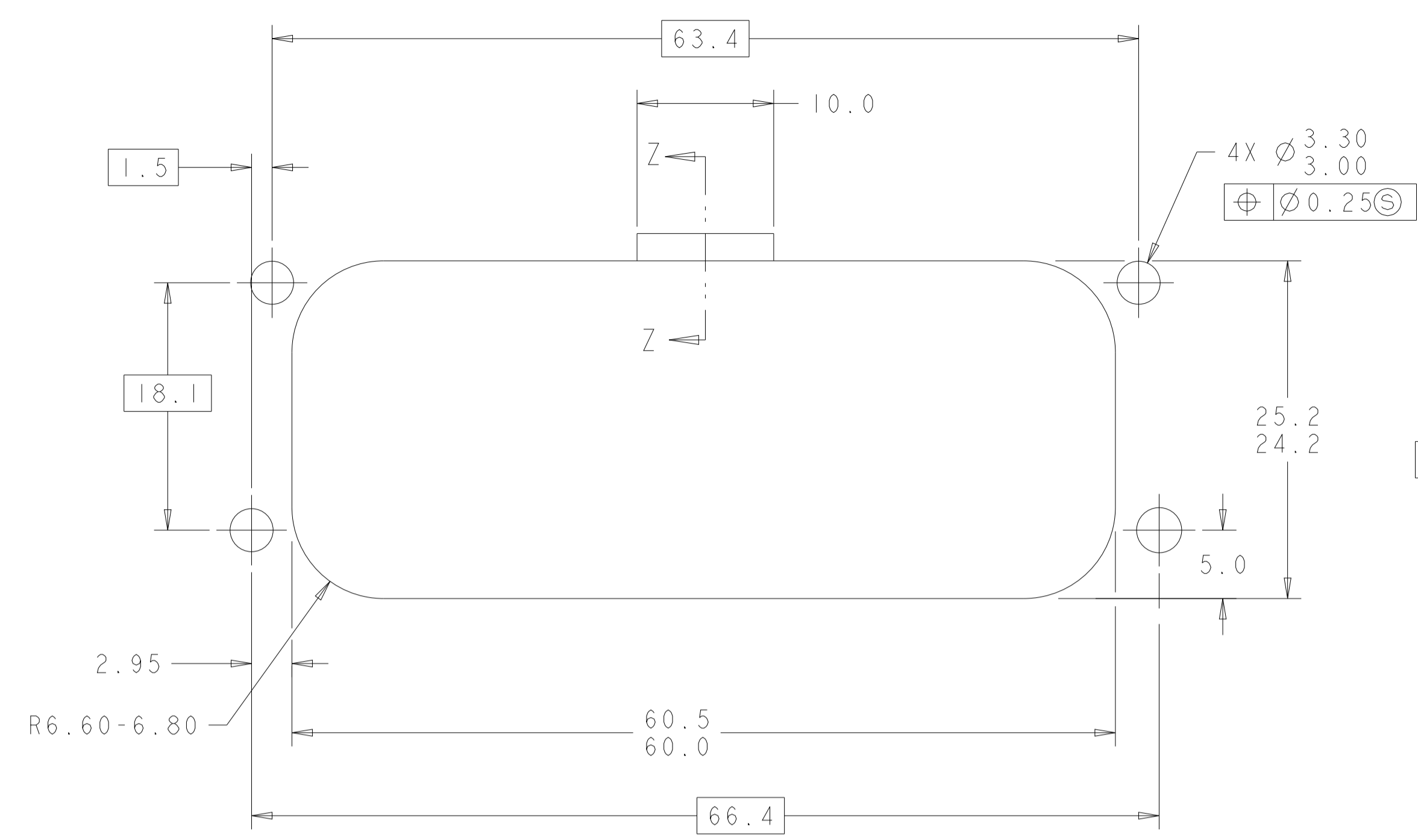

RECOMMENDED MOUNTING HOLE LAYOUT  
 FOR 5.0 MAX THICK PANEL  
 SCALE 3:1

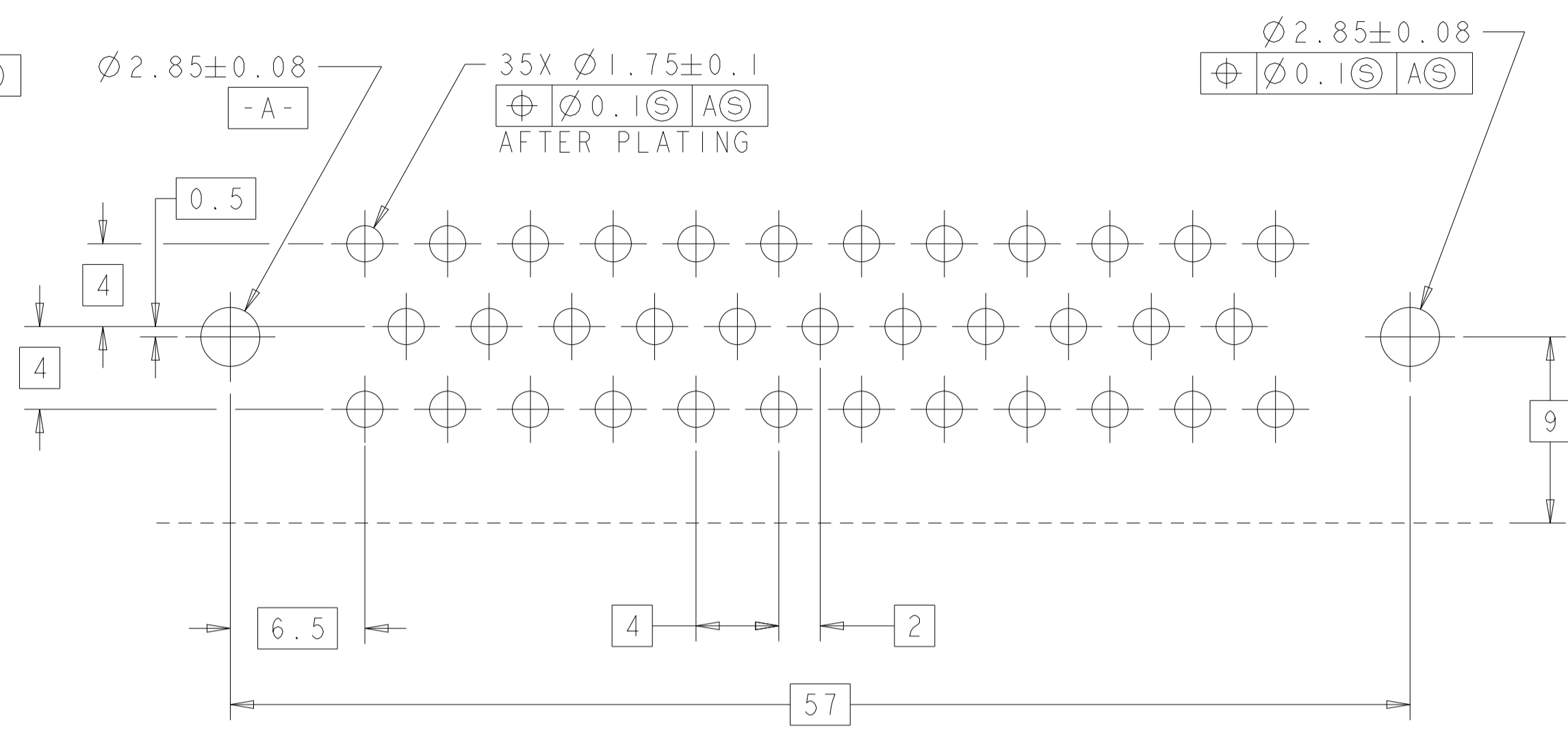

RECOMMENDED P.C. BOARD LAYOUT  
 FOR 1.57 THICK P.C. BOARD

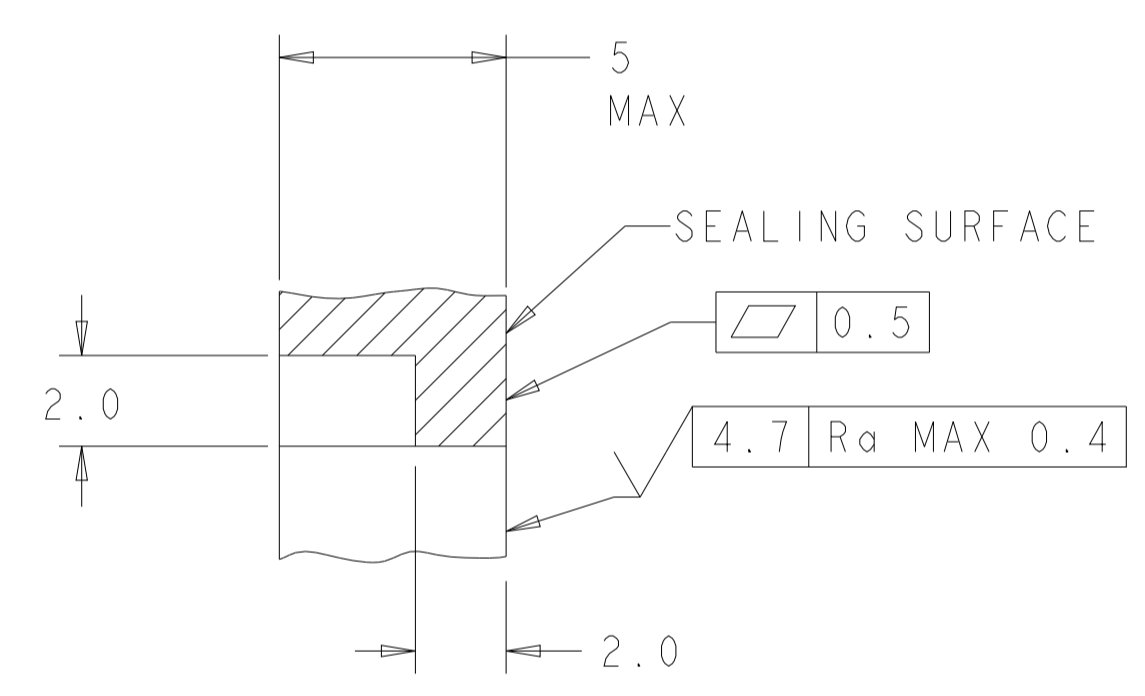

SECTION Z-Z  
 OPTIONAL CONSTRUCTION IF  
 THICKNESS IS GREATER THAN 2.0  
 SCALE 6:1

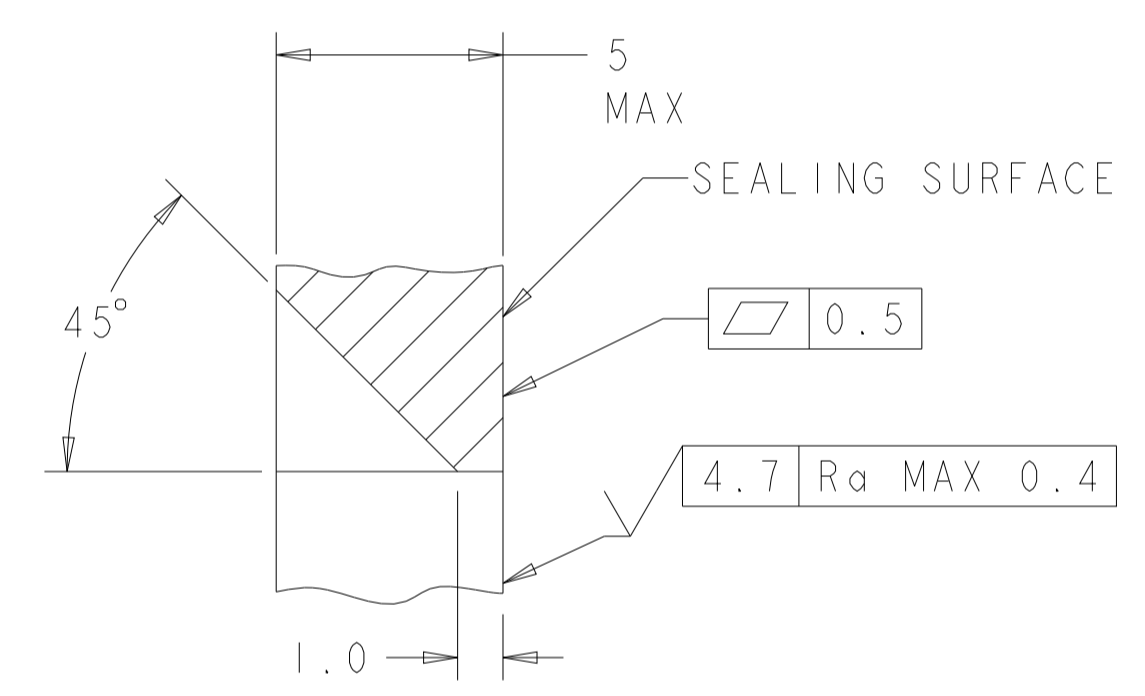

SECTION Z-Z  
 OPTIONAL CONSTRUCTION IF  
 THICKNESS IS GREATER THAN 2.0  
 SCALE 6:1

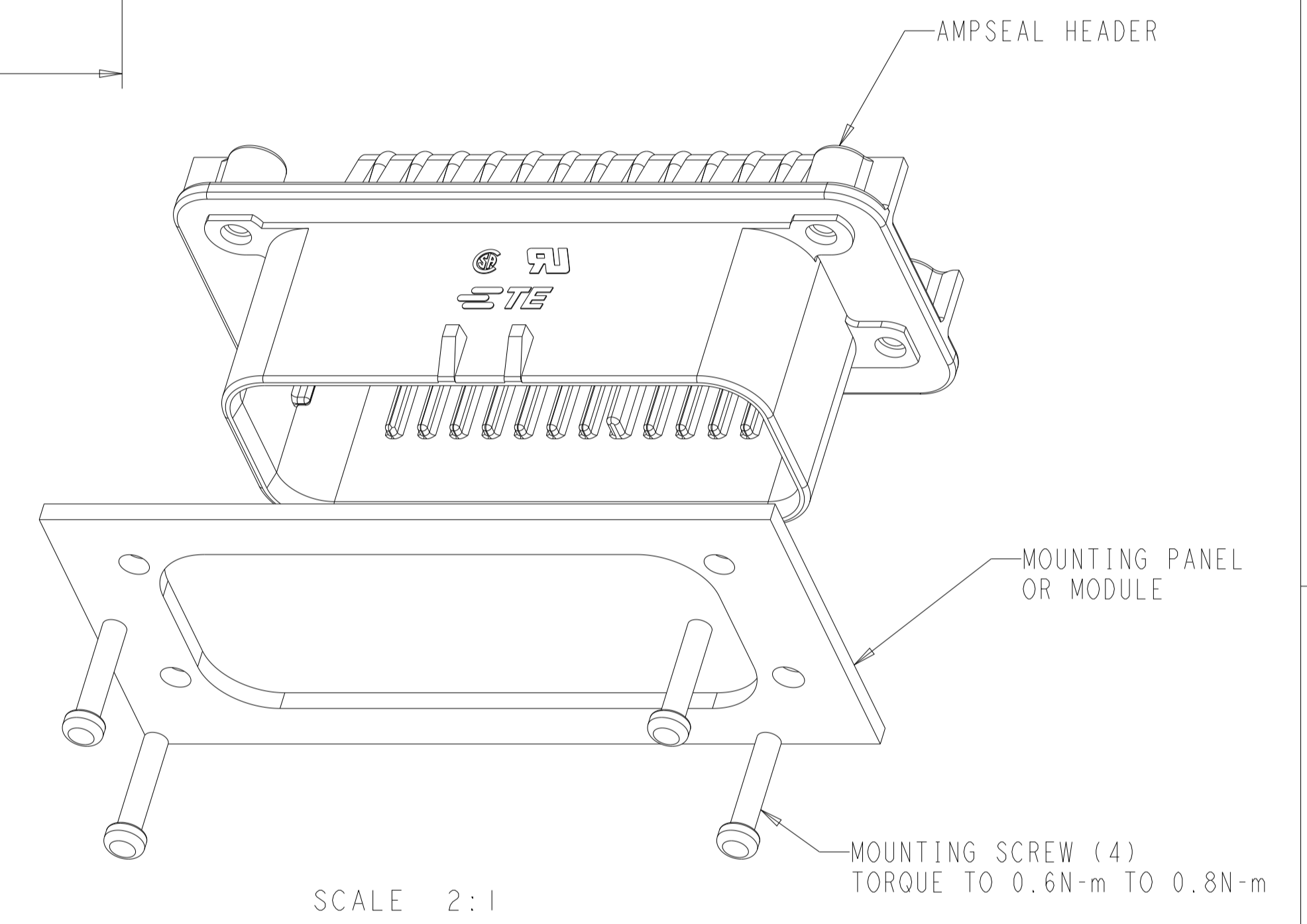

SCALE 2:1

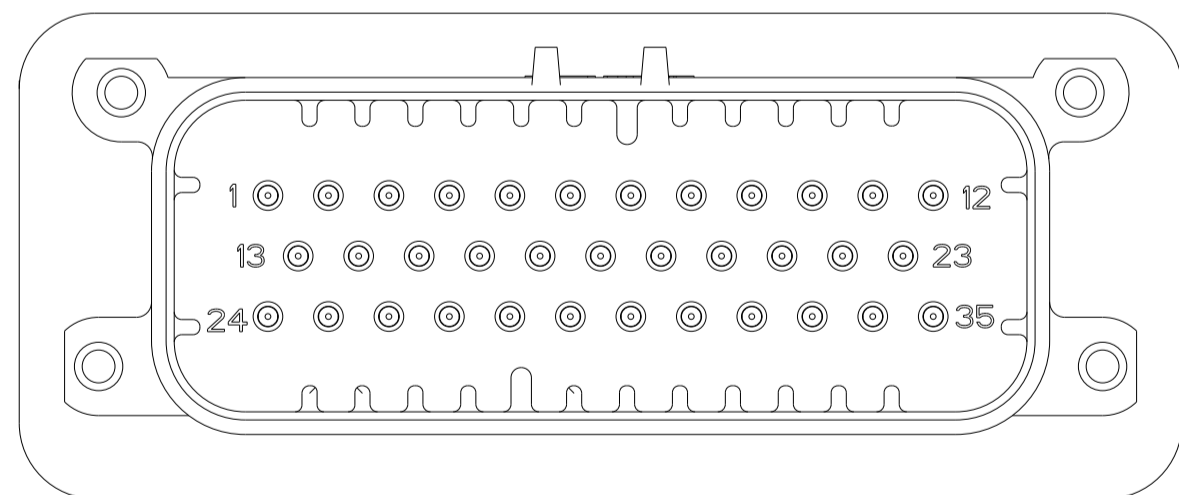

776180-2 & 1-776180-2  
 KEY LOCATION AS SHOWN  
 SCALE 2:1

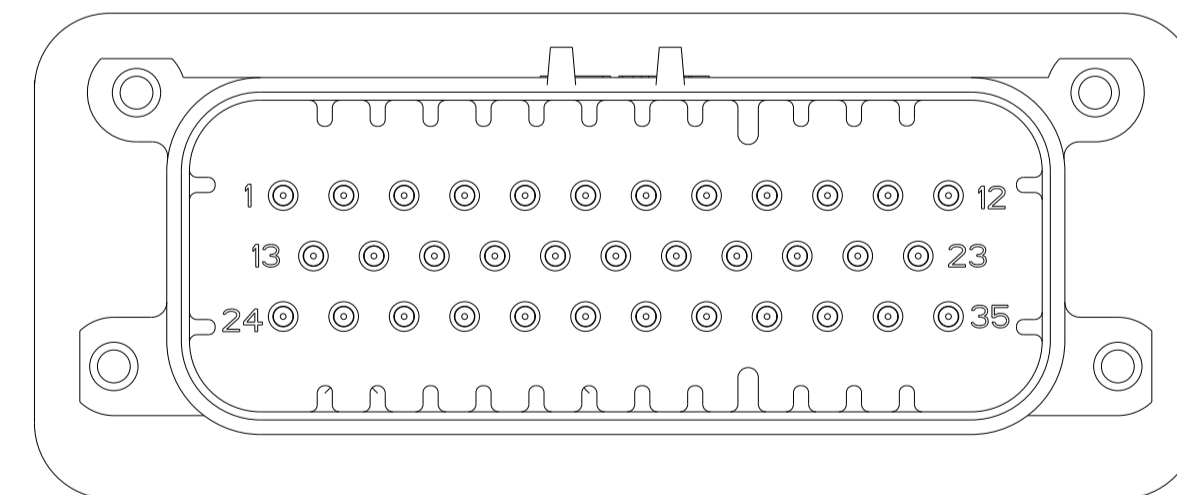

776180-4 & 1-776180-4  
 KEY LOCATION AS SHOWN  
 SCALE 2:1

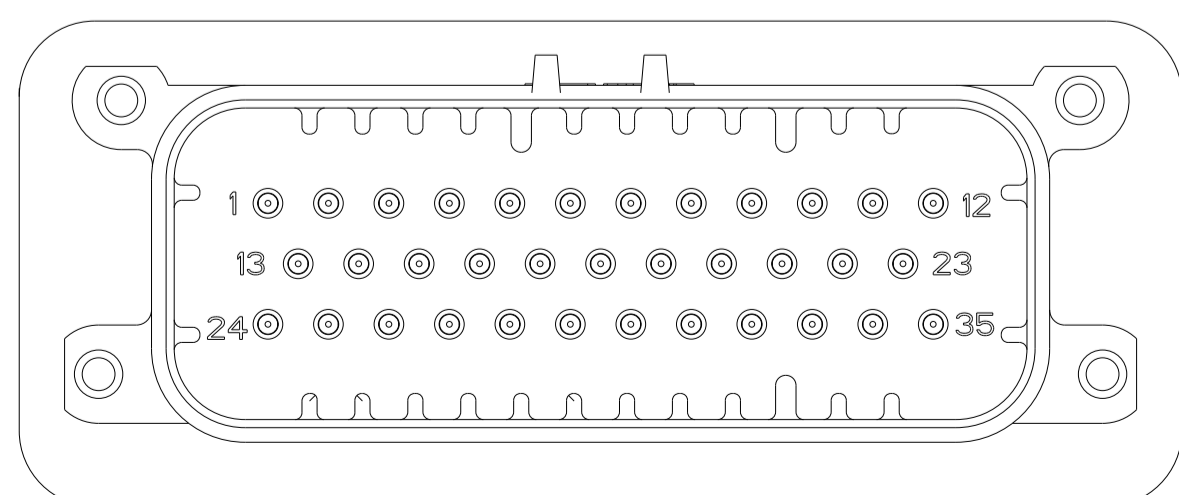

776180-5 & 1-776180-5  
 KEY LOCATION AS SHOWN  
 SCALE 2:1

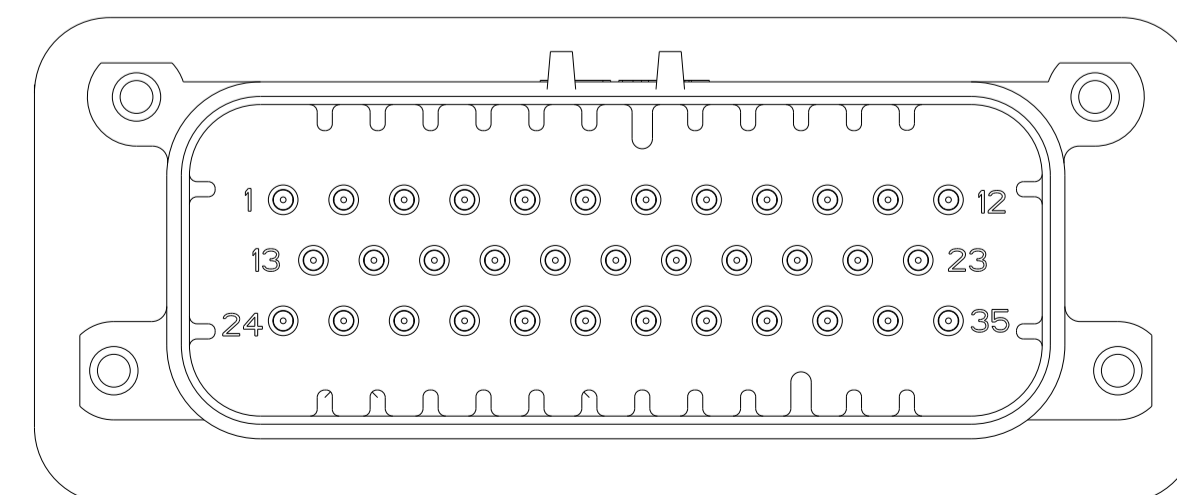

1-776180-6  
 KEY LOCATION AS SHOWN  
 SCALE 2:1

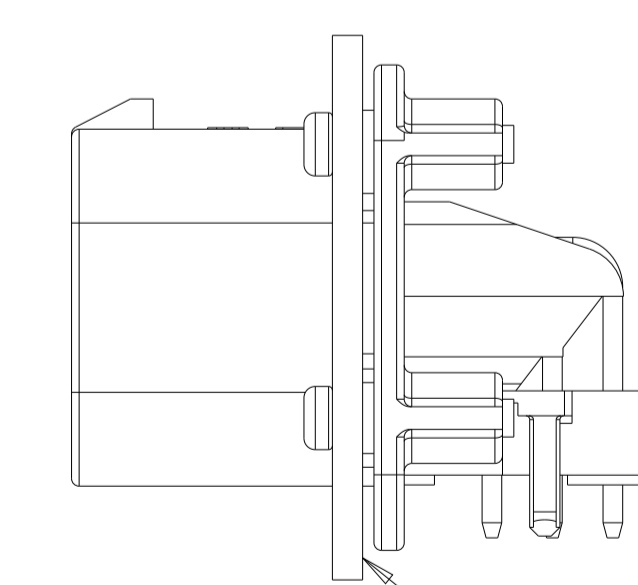

SCALE 2:1

THIS DRAWING IS A CONTROLLED DOCUMENT.		OWN R. VESTAL 31DEC2002	TE Connectivity	
DIMENSIONS:		CHK D. CROWE 31DEC2002	NAME	
mm	TOLERANCES UNLESS OTHERWISE SPECIFIED:	APVD D. CROWE 31DEC2002	HEATER ASSEMBLY, 35 POSITION, RIGHT ANGLE, AMPSEAL	
0 PLC	±	PRODUCT SPEC	SIZE	CAGE CODE
1 PLC	±0.2	108-1329	114-16016	RESTRICTED TO
2 PLC	±	APPLICATION SPEC	WEIGHT	40.45g
3 PLC	±	ANGLES	MATERIAL	
4 PLC	±	FINISH	CUSTOMER DRAWING	
SCALE 4:1		SHEET 2 OF 2		REV J