

# Bourns®

# TCS™ High-Speed Protector (HSP) Evaluation Boards

## TECHNICAL NOTE



TCS-DL004-250-WH

### Introduction

This set of three evaluation boards aids in evaluating the use of a Bourns® TCS™ High-Speed Protector (HSP) in conjunction with a TVS diode to protect a signal line. Each of the three evaluation boards can be detached from the main board, and cut and jumpered into an existing circuit design for easy system evaluation. They can also be used to evaluate the performance of the HSP devices on the lab bench. Each board contains one dual channel HSP and two TVS diodes, one from each line to ground on the input side of the board. Figure 1 shows the schematic for each of the three boards. The only difference between them is which HSP device is installed. The HSP part number is shown on the bottom side of each board (see figure 3). Each board comes with two CDSOD323-T05C bidirectional TVS diodes ( $V_{RWM} = 5\text{ V}$ ) installed. They can be replaced with different voltage devices when the application requires it.

The smaller boards can be separated by placing the board on a flat surface, such as a lab bench, with the section that you want to detach hanging over the edge of the surface. You can then bend the board using two hands so that it breaks on the score line. It does take a reasonable amount of force to detach it. If it helps to make the board shorter, the ends can be broken off along the score lines using a similar technique.

### Performance

The TCS™ HSP family of electronic current limiters is designed to limit current to a preset level under transient conditions while providing a low impedance under normal circuit operation. The test circuit in figure 4 was used to demonstrate the performance of the TCS-DL004-250-WH under surge conditions. Figures 5 and 6 show the performance of the circuit

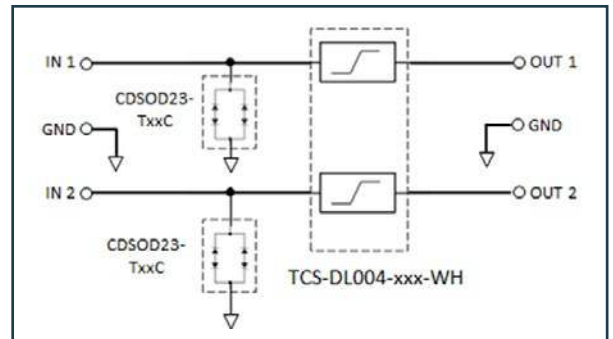

Figure 1 | Evaluation Board Schematic



Figure 2 | Top Side of PCB

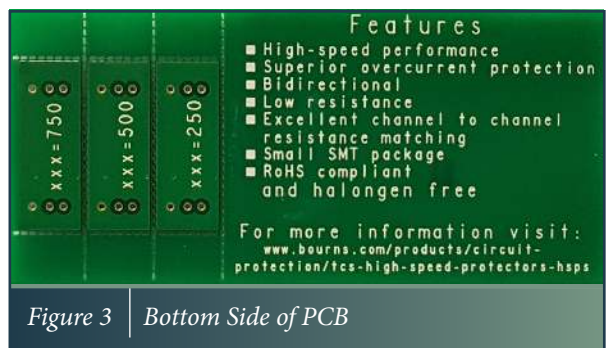

Figure 3 | Bottom Side of PCB

when subjected to a 1.2/50  $\mu\text{s}$  voltage, 8/20  $\mu\text{s}$  current combination waveform with a peak amplitude of 600 V. Note that with this test circuit the voltage across the HSP device is the same as the voltage across the TVS diode. After the brief peak current of 690 mA the current through the HSP device is limited to just over 300 mA.

# Bourns®

# TCS™ High-Speed Protector (HSP) Evaluation Boards

## TECHNICAL NOTE



TCS-DL004-250-WH

### Using the Evaluation Boards

Each of the three evaluation boards is capable of protecting two signal lines. In a typical application, the ESD protection internal to the IC being protected will provide a path for the current flowing through the HSP device. In cases where the internal ESD protection is not robust enough, a second TVS diode must be added to the IC side of the HSP. In transformer coupled differential signal applications where the transformer

provides protection against common mode transients, the two TVS diodes on the board can be replaced with a single TVS diode placed across the signal lines. The pad spacing was designed to accommodate placing a diode in a SOD323 package between the signal lines (see figure 2). The I/O pads are sized to accommodate gauge 24 or higher wire sizes.

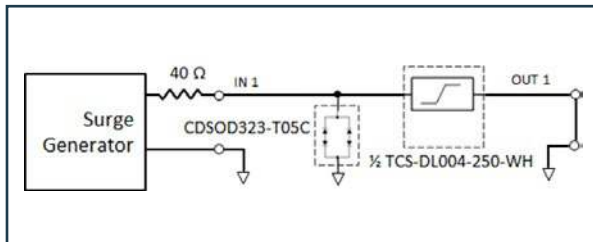

Figure 4 | TCS™ HSP Surge Test Circuit

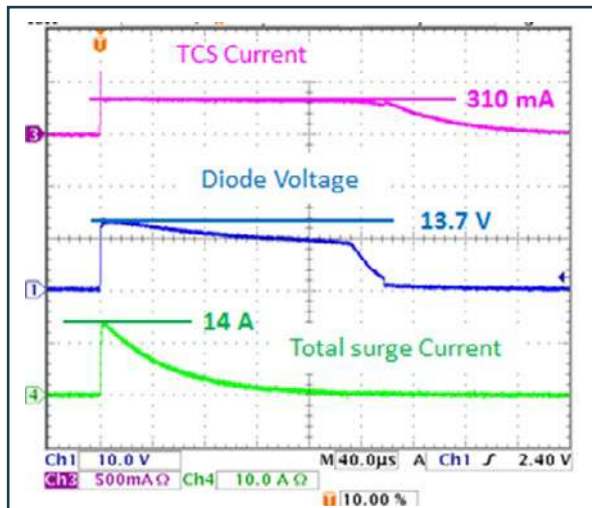

Figure 5 | Surge Performance

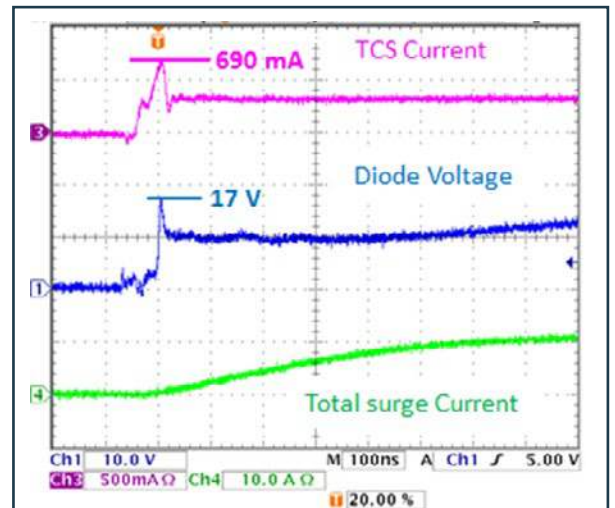

Figure 6 | Surge Performance (Zoomed In)

For more information on the Bourns® TCS™ High-Speed Protector Series, please visit [www.bourns.com](http://www.bourns.com)

**BOURNS®**

COPYRIGHT © 2016 • BOURNS, INC. • 06/16 • e/TCS1602

“TCS” is a trademark of Bourns, Inc. in the U.S. and other countries.  
“Bourns” is a registered trademark of Bourns, Inc. in the U.S. and other countries.

Americas: Tel +1-951 781-5500  
Email [americus@bourns.com](mailto:americus@bourns.com)

EMEA: Tel +36 88 520 390  
Email [eurocus@bourns.com](mailto:eurocus@bourns.com)

Asia-Pacific: Tel +886-2 256 241 17  
Email [asiacus@bourns.com](mailto:asiacus@bourns.com)