

4

3

2

1

THIS DRAWING IS UNPUBLISHED.

RELEASED FOR PUBLICATION

© COPYRIGHT

ALL RIGHTS RESERVED.

LOC DIST

REVISIONS

P	LTR	DESCRIPTION	DATE	DWN	APVD
	C1	ECR-13-009806	18JUN2013	MY	GB

REPLACED BY OCEAN STYLE APPLICATOR PART NUMBER 2151068-2

FOR REPLACEMENT PARTS FOR APPLICATOR 1530185 REFER TO ADDITIONAL PAGE(S). SPARE PARTS KIT (IF LISTED) WILL REMAIN AVAILABLE.

THE REPLACEMENT OCEAN STYLE APPLICATOR HAS THE SAME TERMINATOR/PRESS INTERFACE AS APPLICATOR 1530185

Dimensioning and tolerancing per ASME Y14.5M-2009

B

A

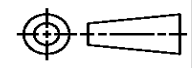
THIS DRAWING IS A CONTROLLED DOCUMENT.		DWN M. YOUNGER	 TE Connectivity	
DIMENSIONS:		CHK G. BAILEY		
		APVD G. BAILEY	NAME FINE ADJUST SIDE FEED HDI APPLICATOR	
TOLERANCES UNLESS OTHERWISE SPECIFIED:		PRODUCT SPEC	APPLICATION SPEC	
0 PLC ± 1 PLC ± 2 PLC ± 3 PLC ± 4 PLC ± ANGLES ±		WEIGHT	SIZE A3	CAGE CODE
MATERIAL		FINISH	DRAWING NO C- 1530185	
		CUSTOMER ACCESSIBLE PRODUCTION DRAWING		RESTRICTED TO
		SCALE	SHEET 1 OF 2	REV C1

Dimensioning and tolerancing per ASME Y14.5M-2009

PART NUMBER	REV	TERMINATOR	FEED TYPE	DESCRIPTION
1530185-1	C	LEADMAKER	PNEUMATIC FEED	CUTS CARRIER
1530185-2	C	BENCH	PNEUMATIC FEED	CUTS CARRIER
1530185-6	C	LEADMAKER	PNEUMATIC FEED	CONTINUOUS CARRIER
7-1530185-1	C	LEADMAKER	PNEUMATIC FEED	-1 AND SPARE PARTS
7-1530185-2	C	BENCH	PNEUMATIC FEED	-2 AND SPARE PARTS
7-1530185-6	C	LEADMAKER	PNEUMATIC FEED	-6 AND SPARE PARTS
7-1530185-7	A	-	-	SPARE PARTS KIT

CRIMP DATA		TE TERMINAL	TE CRIMP SPECS
TERMINAL NAME: MCON-1.2 CB			
CRIMP	SIZE	TYPE	RANGE
WIRE	1.57 [.062 IN]	F	20AWG or 0.5mm ² -0.75mm ²
INSUL	1.83 [.072 IN]	O	1.40-1.90 [.055-.075 IN]
WIRE STRIP LENGTH 3.00-3.60 [.118-.142 IN]		APPL INSTRUCTIONS 411-3283	
TERMINAL APPL SPEC 114-18464		FEED 7.50 [.295 IN]	
TERMINALS APPLIED			
WIRE SIZE	CRIMP HEIGHT	REF SETTING	
0.75mm ²	0.95 ± 0.05 [.037 ± .002 IN]	C2	
0.50mm ² or 20AWG	0.84 ± 0.05 [.033 ± .002 IN]	D0	

- 1 RECOMMENDED SPARE PARTS.
- 2 GREASE RAM, CAM, CAM FOLLOWER AND FEED ROD LIGHTLY.
- 3. CERTAIN TERMINALS REQUIRE LUBRICATION. REFER TO THE TERMINATING UNITS DOCUMENTATION.
- 4. LUBRICATE DAILY PER THE APPLICATOR INSTRUCTION SHEET SUPPLIED WITH THE APPLICATOR.

*** WARNING**
ON INSTALLATION, SET WIRE DISC TO LARGEST WIRE SIZE SETTING. USE OF SETTINGS BELOW MIN. REQUIRED CRIMP HEIGHT SETTING WILL CAUSE DAMAGE TO CRIMP TOOLING.

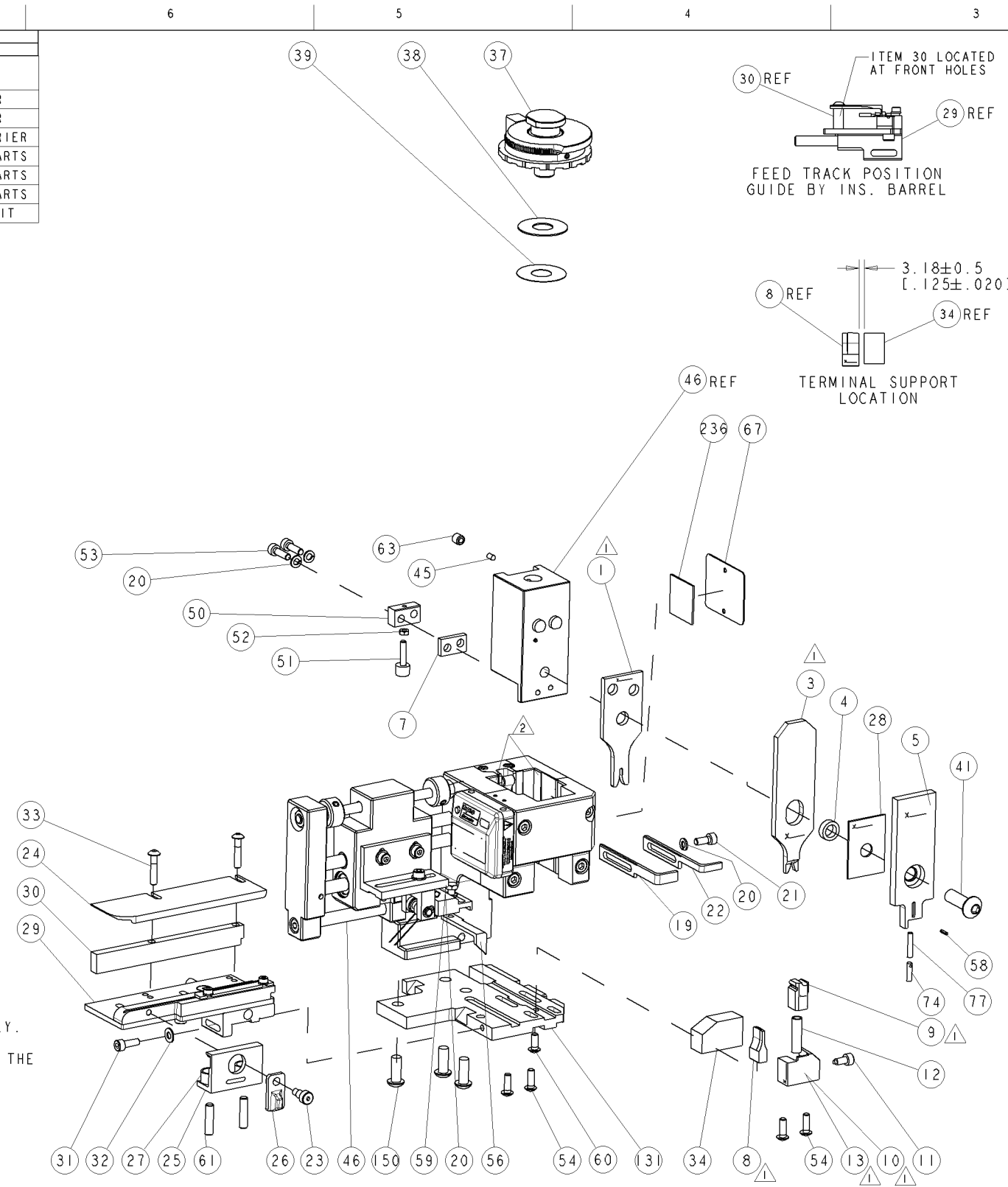

SET UP GAGE
458637-3

REVOLUTIONS		DATE	BY	APP'D
A	RELEASED	12OCT2009	RK	GB
B	ECR-09-027538	17DEC2009	BH	BH
C	ECR-10-008372	20APR2010	TY	SX

AR	AR	AR	AR	AR	AR	AR	982057-2	TAPE, FOAM	236
-	3	3	3	3	3	3	994988-1	SCR, BTN SKT HD CAP M6X16.0 W/NYLOK	150
-	1	1	1	1	1	1	1320992-1	PLATE, BASE	131
-	1	1	1	1	1	1	22278-7	SPRING, COMPRESSION	77
-	1	1	1	1	1	1	854769-4	HOLDER, INS	74
-	1	1	1	1	1	1	1338705-8	DOCUMENTATION PACKAGE	71
-	1	1	1	1	1	1	1-461264-0	PLATE, IDENTIFICATION	67
-	1	1	1	1	1	1	3-18031-0	SCR, SET, CUP POINT M6 X 6.0	63
-	2	2	2	2	2	2	2-18032-5	SCR, SET, FLT POINT M5 X 20.0	61
-	1	1	1	1	1	1	18024-7	SCR, BTN SKT HD CAP (M4 X 10.0)	60
-	1	1	1	1	1	1	5-18022-2	SCR, HEX HD CAP M4 X 8.0	59
-	1	1	1	1	1	1	21028-2	PIN, SLOTTED SPRING .062 X .250	58
-	1	1	1	1	1	1	1338685-1	PAWL, FEED	56
-	4	4	4	4	4	4	18024-8	SCR, BTN SKT HD CAP (M4 X 12.0)	54
-	2	2	2	2	2	2	9-18023-6	SCR, SKT HD CAP M4 X 14.0	53
-	1	1	1	1	1	1	18030-1	NUT, HEX, REG M3	52
-	1	1	1	1	1	1	811242-5	BUMPER, HOLD DOWN	51
-	1	1	1	1	1	1	690753-2	SPACER, TONKER	50
-	1	1	1	1	1	1	1333303-1	ASSEMBLY, AIR FEED	46
-	1	1	1	1	1	1	690191-1	PLUG, NYLON	45
-	-	-	-	-	-	-	-	-	44
-	1	1	1	1	1	1	2-18024-6	SCR, BTN SKT HD CAP (M8 X 25.0)	41
-	1	1	1	1	1	1	690125-1	SHIM SUB-ASSY	39
-	1	1	1	1	1	1	469367-8	SHIM	38
-	1	1	1	1	1	1	879103-3	FINE ADJUST HEAD ASSEMBLY	37
-	1	1	1	1	1	1	1752356-6	SUPPORT, TERMINAL	34
-	2	2	2	2	2	2	1-18024-0	SCR, BTN SKT HD CAP (M4 X 20.0)	33
-	1	1	1	1	1	1	18027-2	WASHER, FLAT, REG M4	32
-	1	1	1	1	1	1	1-18023-2	SCR, SKT HD CAP M4 X 12.0	31
-	1	1	1	1	1	1	1320908-1	SPACER, STRIP GUIDE	30
-	1	1	1	1	1	1	1633073-2	STRIP GUIDE ASSEMBLY	29
-	1	1	1	1	1	1	1-455888-0	SPACER, CRIMPER	28
-	2	2	2	2	2	2	1-22284-0	SPRING, COMPRESSION	27
-	1	1	1	1	1	1	356835-1	LEVER, DRAG RELEASE	26
-	1	1	1	1	1	1	240792-1	DRAG, TERMINAL	25
-	1	1	1	1	1	1	1320928-1	PLATE, STRIP GUIDE	24
-	1	1	1	1	1	1	980371-4	SCR, SKT HD SHLDR 5.0 DIA X 6.0	23
-	1	1	1	1	1	1	690472-2	STRIPPER	22
-	1	1	1	1	1	1	1-18023-1	SCR, SKT HD CAP M4 X 10.0	21
-	4	4	4	4	4	4	18025-2	WASHER, SPRG LOCK, REG M4	20
-	-	-	-	-	-	-	690472-1	STRIPPER	19
-	1	1	1	1	1	1	1338684-1	SHEAR HOLDER, FRONT	13
-	1	1	1	1	1	1	3-22280-3	SPRING, COMPRESSION	12
-	1	1	1	1	1	1	356885-4	STOP, SHEAR	11
-	1	1	1	1	1	1	1320921-1	SHEAR HOLDER, FRONT, CUT	10
-	1	1	1	1	1	1	462006-1	FLOATING SHEAR, FRONT	9
-	1	2	2	2	2	2	1333231-2	ANVIL, COMBINATION, SPECIAL	8
-	1	1	1	1	1	1	240641-5	SPACER	7
-	-	-	-	-	-	-	-	-	6
-	1	1	1	1	1	1	854772-1	DEPRESSOR, SHEAR	5
-	1	1	1	1	1	1	4-238011-2	BLOCK, CRIMPER SPACER	4
-	1	2	2	2	2	2	1752766-1	CRIMPER, INSULATION, SPECIAL	3
-	-	-	-	-	-	-	-	-	2
-	1	2	2	2	2	2	5-456403-0	CRIMPER, WIRE PREMIUM	1

AR	AR	AR	AR	AR	AR	AR	PART NO	DESCRIPTION	ITEM NO
-	77	-	76	-	72	-	71	-	6
-	-	-	-	-	-	-	-	-	2
-	-	-	-	-	-	-	-	-	1