

Customer Information Sheet

DRAWING No.: S0921-46R

IF IN DOUBT - ASK

©

NOT TO SCALE

THIRD ANGLE PROJECTION

ALL DIMENSIONS IN mm

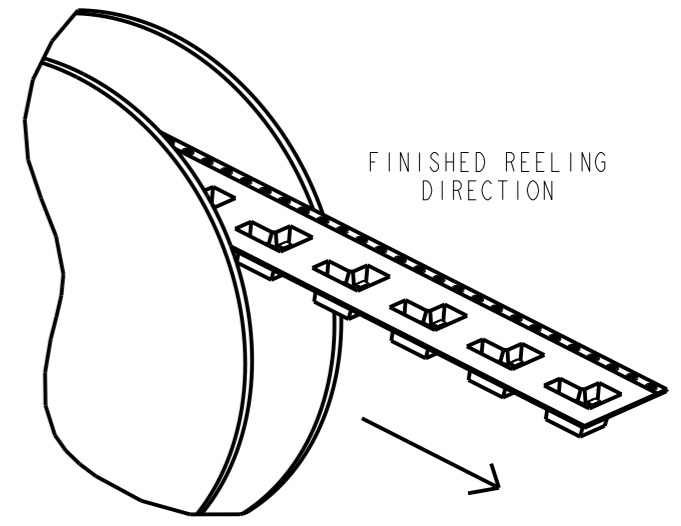
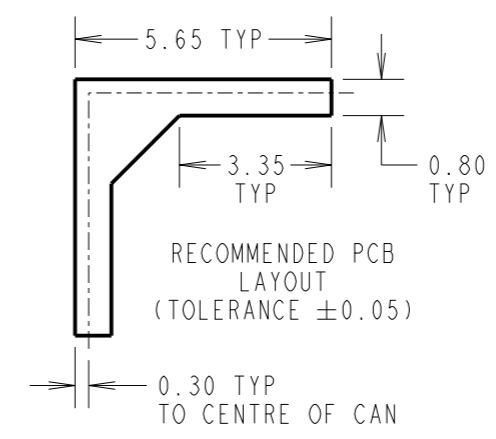
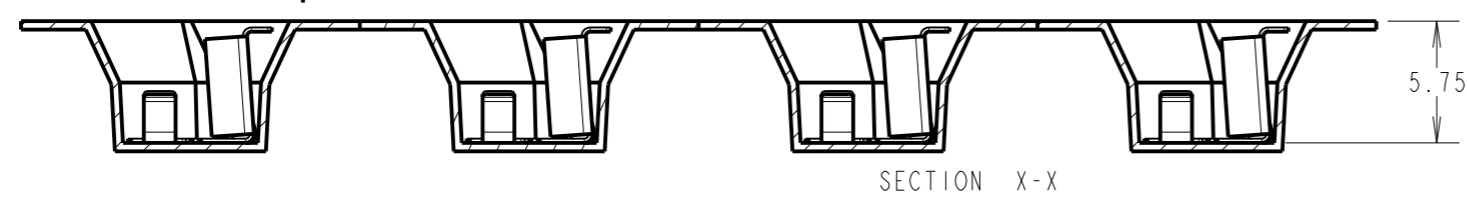
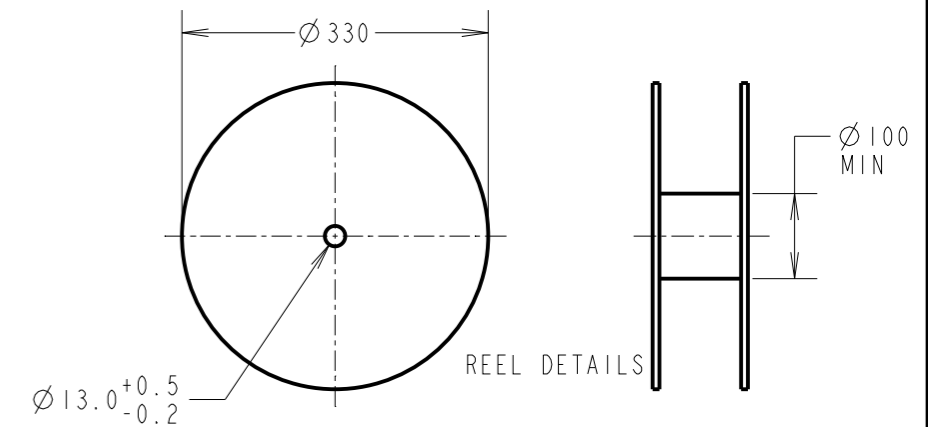
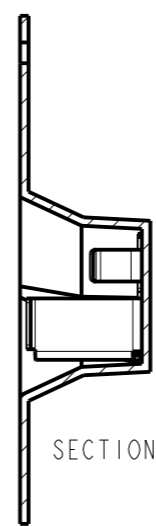
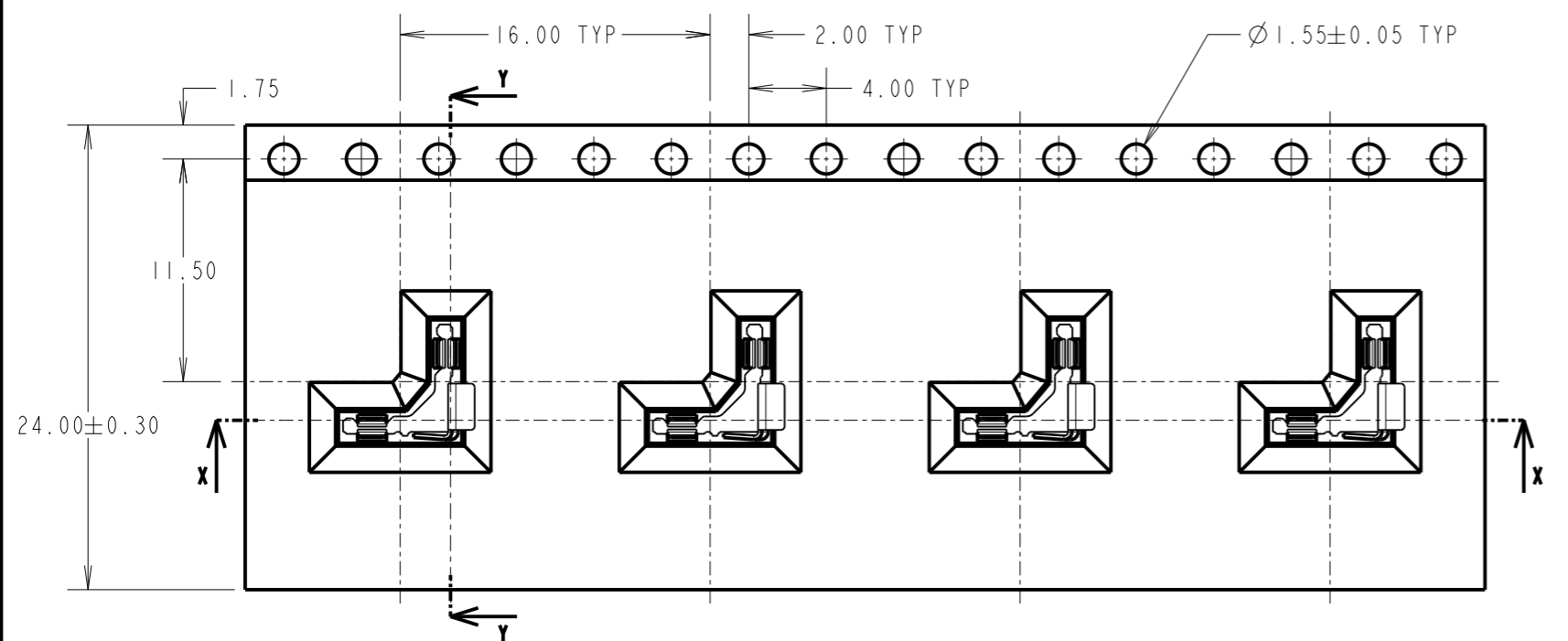

PATENTED TECHNOLOGY

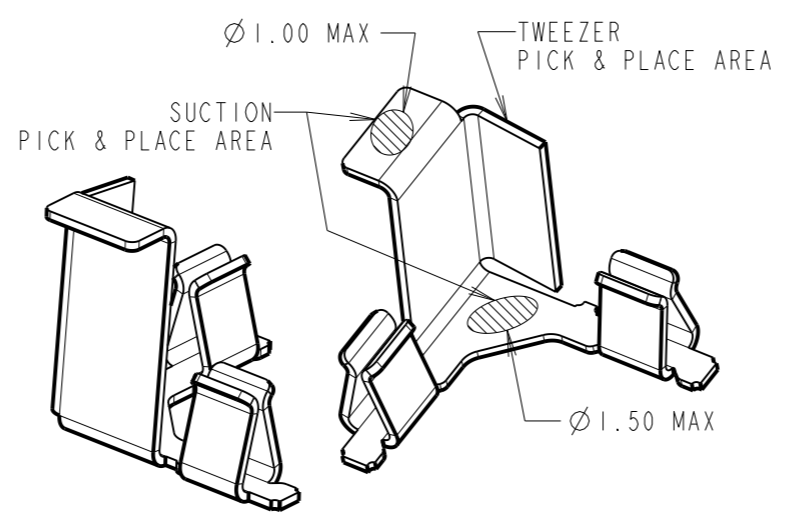
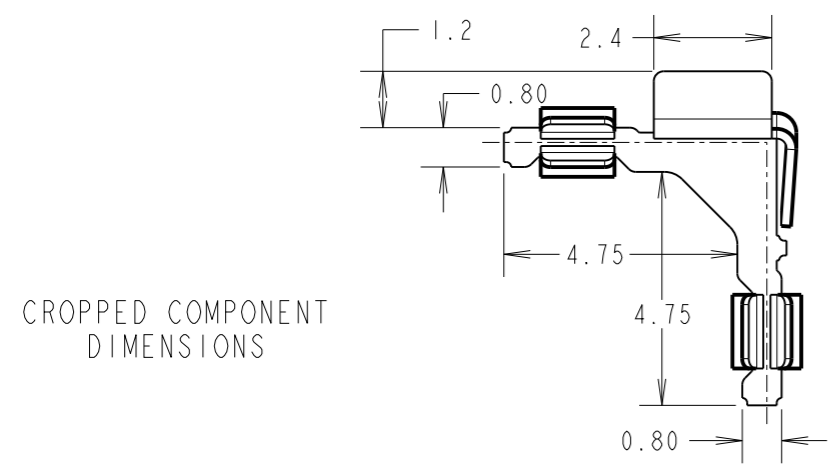

COMPONENT SPECIFICATION:
 MATERIAL = CUPRO NICKEL
 FINISH = 2.4-3.6µm 100% TIN OVER 2.0-2.8µm NICKEL
ELECTRICAL:
 CONTACT RESISTANCE = 25mΩ MAX
MECHANICAL:
 MAX INSERTION FORCE WITH 0.30mm SHEET = 15.00N
 MIN INSERTION FORCE WITH 0.30mm SHEET = 0.75N
 MAX WITHDRAWAL FORCE WITH 0.30mm SHEET = 6.00N
 MIN WITHDRAWAL FORCE WITH 0.30mm SHEET = 0.30N
 DURABILITY = 20 CYCLES
ENVIRONMENTAL:
 OPERATING TEMPERATURE = -55°C TO +105°C

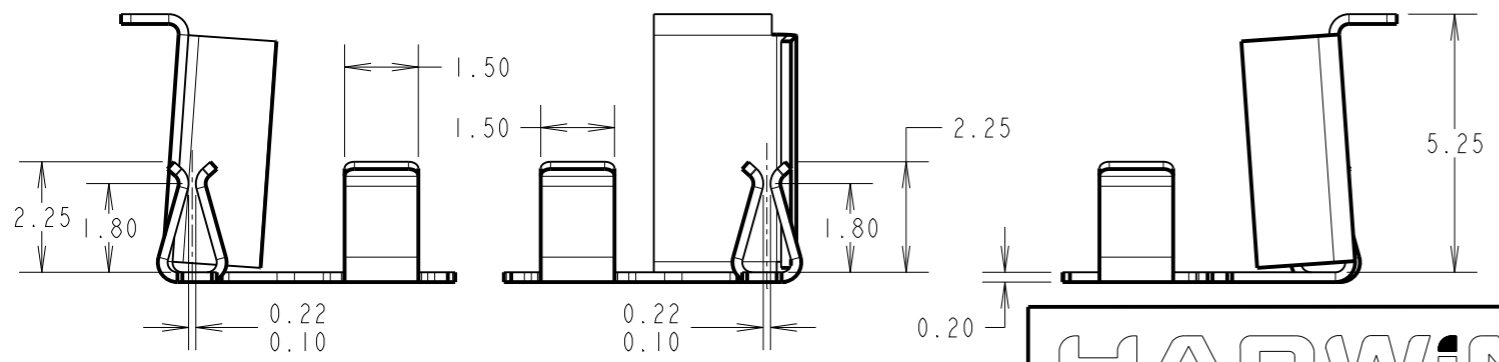

- NOTES:**
1. QUANTITY OF COMPONENTS PER REEL: 600.
 2. THIS PRODUCT IS TAPE AND REELED IN GENERAL ACCORDANCE WITH EIA-481-2 (ELECTRONICS INDUSTRIES ASSOCIATION).
 3. RECOMMENDED CAN THICKNESS: 0.30-0.40mm.

AB	4	25.11.22	32082
NAME	ISS.	DATE	CN/CO
APPROVED:		A.BOXALL	
CHECKED:		R.PORTLOCK	
DRAWN:		S.BENNETT	
CUSTOMER REF.:			
ASSEMBLY DRG:			

HARWIN
 www.harwin.com
 technical@harwin.com

THIS DRAWING AND ANY INFORMATION OR DESCRIPTIVE MATTER SET OUT HEREON ARE CONFIDENTIAL AND COPYRIGHT PROPERTY OF THE HARWIN GROUP AND MUST NOT BE DISCLOSED, LOANED, COPIED OR USED FOR MANUFACTURING, TENDERING OR FOR ANY OTHER PURPOSE WITHOUT THEIR WRITTEN PERMISSION.

TOLERANCES
 X. = ±1mm
 X.X = ±0.50mm
 X.XX = ±0.20mm
 X.XXX = ±0.01mm
 ANGLES = ±5°
 UNLESS STATED

MATERIAL:
 SEE ABOVE
FINISH: SEE ABOVE
S/AREA: mm²

TITLE:
 CORNER RFI SHIELD CLIP
 IN TAPE AND REEL
DRAWING NUMBER:
S0921-46R
 SHT 2 OF 2