

THIS DRAWING IS UNPUBLISHED. RELEASED FOR PUBLICATION
© COPYRIGHT 19 BY - ALL RIGHTS RESERVED.

LOC	DIST	REVISIONS					
-	-	P	LTR	DESCRIPTION	DATE	DWN	APVD
			A	DRAWING RELEASE	31/7/07	NH	YP
			B	MODIF TIN BRACKET PLATING- CLARIFICATION	18JUN2013	JT	YP
			C	ADDED NOTE 1	22MAR2019	LN	YP

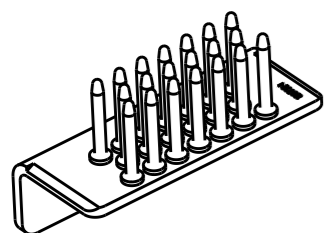

SCALE 1:1

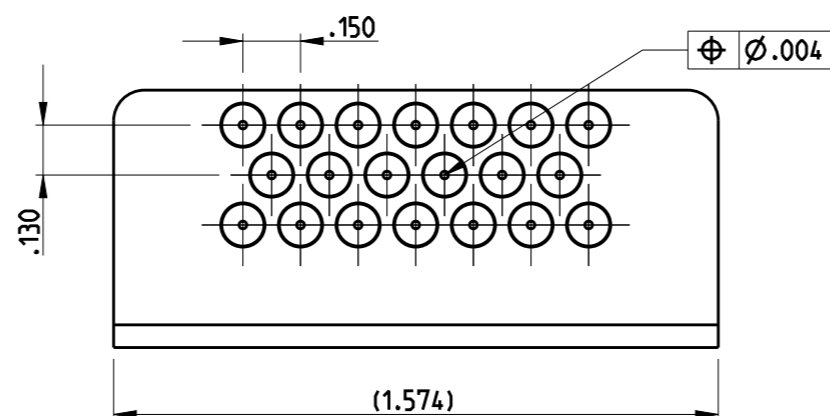
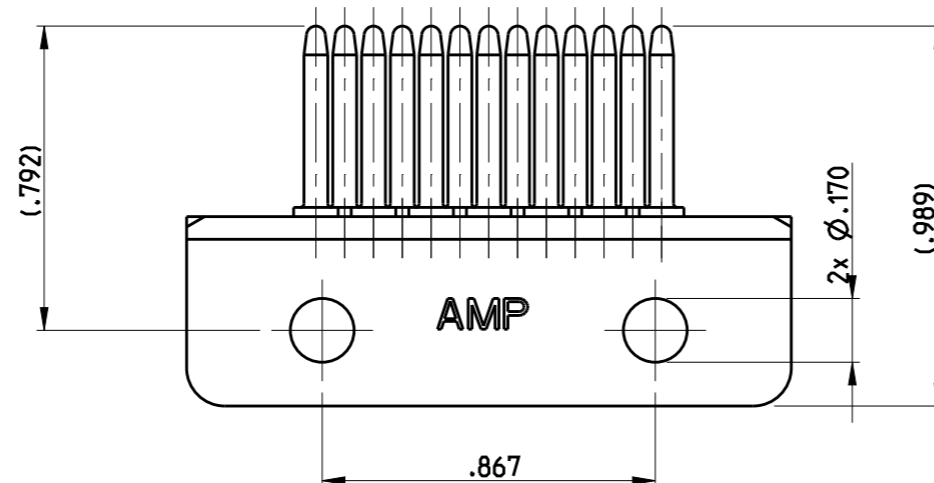
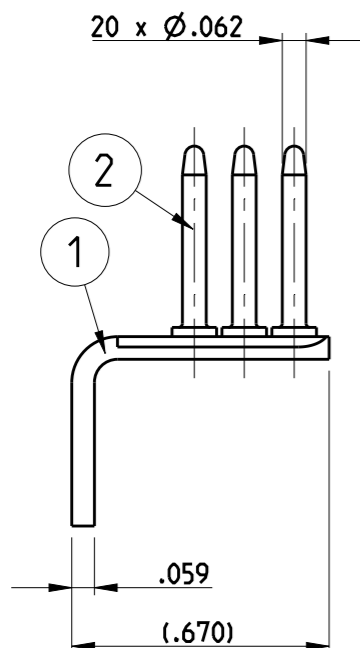
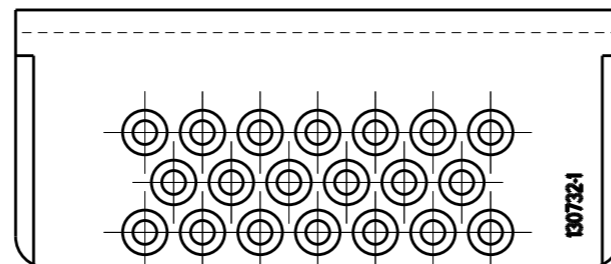

- 1. MATES TO 131435-3. 130733-2. 130733-4.
- 2 .000030 MIN AU OVER NICKEL.
- 3 .00016 MIN Sn. OVER Cu UNDERLAYER

FINISH	MATERIAL	QTY	PART DESCRIPTION	ITEM
2	BRASS	20	PIN	2
3	BRASS	1	BRACKET	1

130732-1
PART NUMBER

THIS DRAWING IS A CONTROLLED DOCUMENT.		DWN 31JULY2007 Niranjan Hegde		TE Connectivity	
DIMENSIONS: Inches		CHK 31JULY2007 Petronin Yves			
TOLERANCES UNLESS OTHERWISE SPECIFIED:		APVD 31JULY2007 Petronin Yves		NAME BRACKET GROUNDING 20 PIN	
0 PLC ±.1		PRODUCT SPEC		SIZE	
1 PLC ±.02		APPLICATION SPEC		CAGE CODE	
2 PLC ±.005		WEIGHT 18 g		DRAWING NO	
3 PLC ±		Customer Drawing		C-130732	
4 PLC ±1°		SCALE 2:1		RESTRICTED TO	
ANGLES ±1°		SHEET 1 OF 1		REV C	
FINISH TABLE					