

FED-26792-102

SHT 1.1

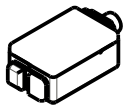
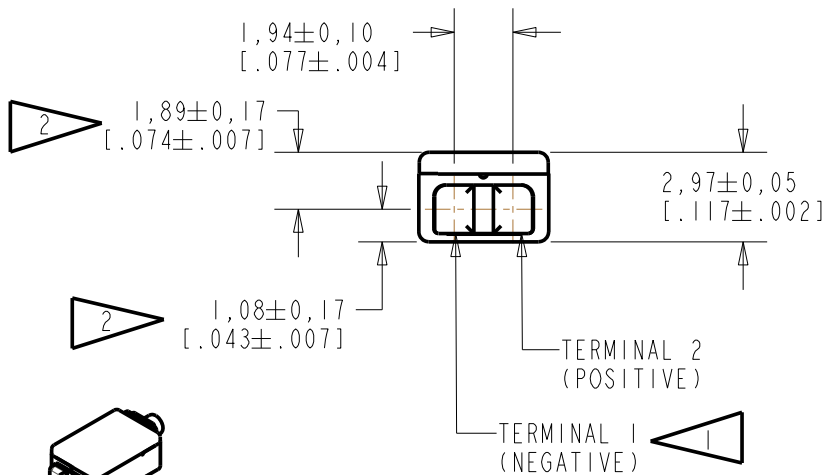
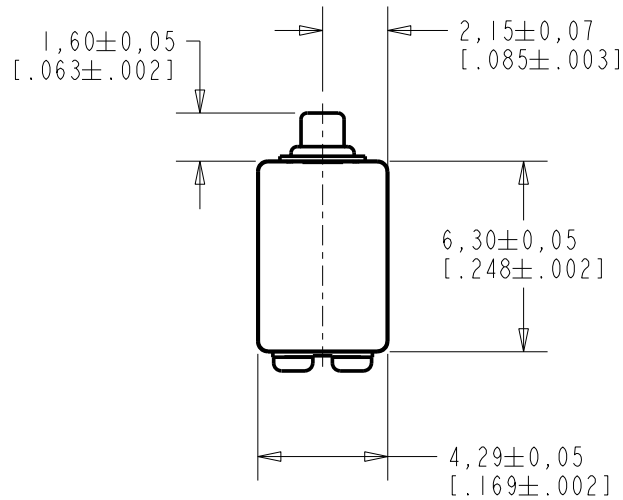

SCALE 2:1

NOMINAL WEIGHT  
.31 GRAMS

DIMENSIONS IN MILLIMETERS [INCHES]

NOTE:

- 1 A POSITIVE GOING VOLTAGE AT TERMINAL 2, RELATIVE TO TERMINAL 1, CAUSES A DECREASE IN PRESSURE AT THE SOUND OUTLET.
- 2 LOCATED FROM TWO SURFACES FOR CUSTOMER CONVENIENCE. ONLY APPLICABLE FROM ONE SURFACE, NOT TO BE USED TOGETHER. HORIZONTAL LOCATION FOR TERMINAL CENTERED TO  $\pm 0,17$  [.007].

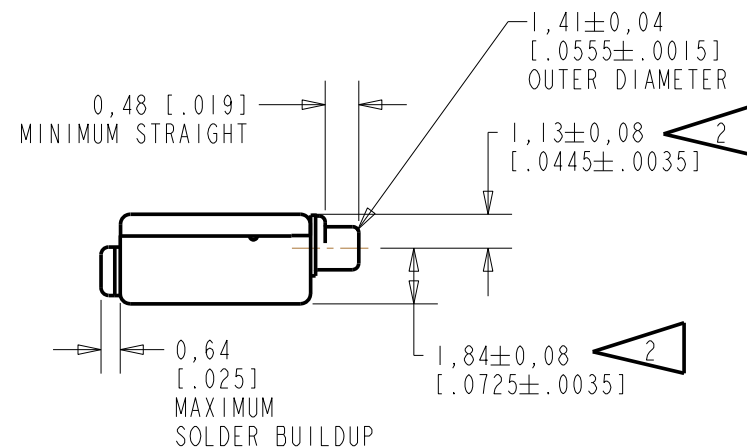

Revision	C.O. #	Implementation Date	RELEASE LEVEL	REVISION
C	C10107990	11-20-08	Active	C
B	C10104212	5-1-06		
A	C10103609	2-2-06		

SCALE: 4:1		DR. BY	DATE
DO NOT SCALE DRAWING		CRG	2-2-06
TITLE: RECEIVER		CK. BY	DATE
OUTLINE DRAWING		GJP	2-8-06
FED-26792-102		APP. BY	DATE
SHT 1.1		GJP	2-8-06

**KNOWLES ELECTRONICS**  
ITASCA, ILLINOIS U.S.A.

THE FED-26792-102 IS A FERROFLUID DAMPED ED-27305 RECEIVER WITH A PEAK OF 2dB RELATIVE TO THE SENSITIVITY AT 1kHz UNDER CONSTANT VOLTAGE DRIVE CONDITIONS.

CONSTANT VOLTAGE DRIVE CONDITIONS

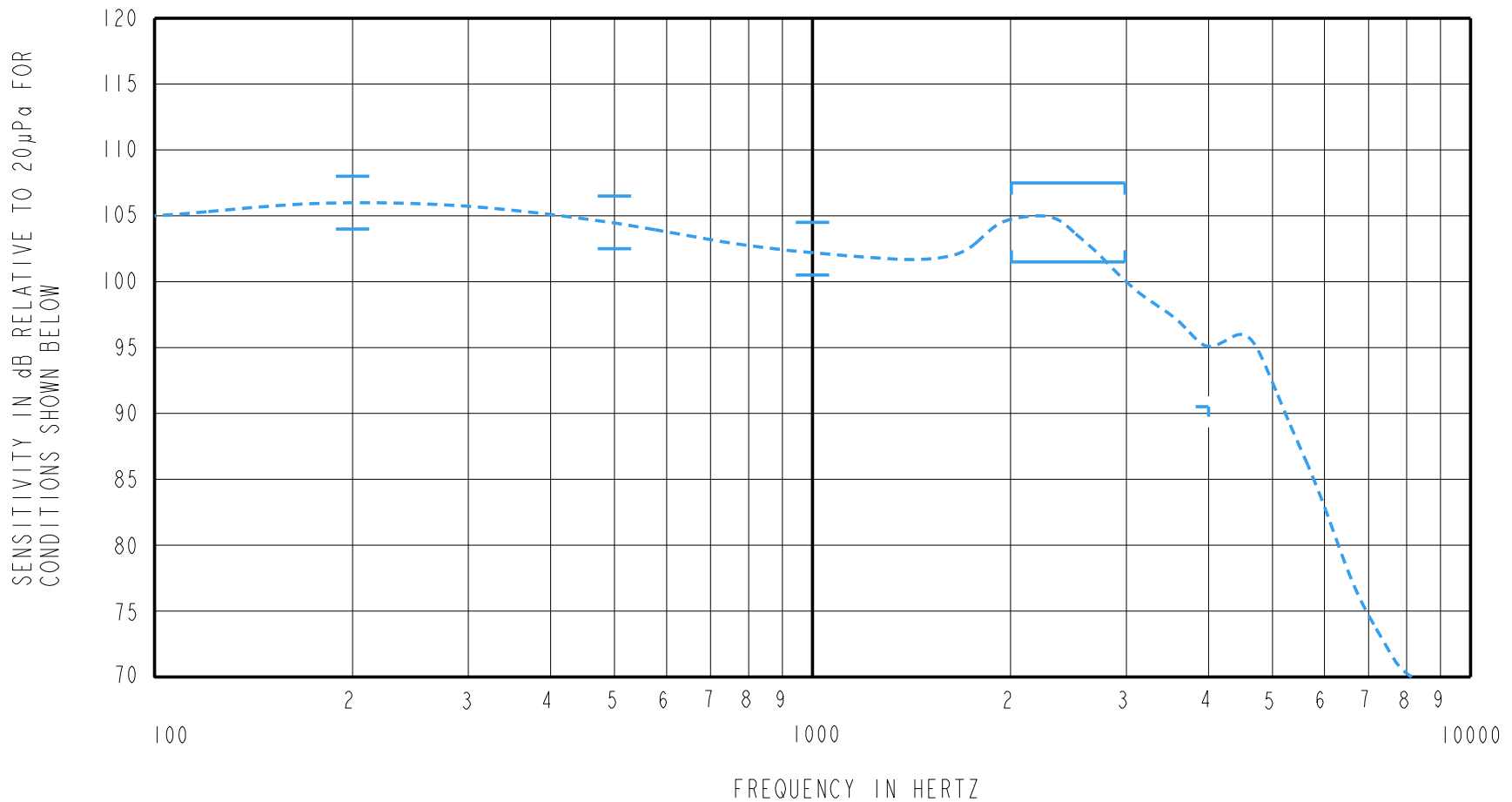

**ACOUSTICAL**

SENSITIVITY  
DEVICE WILL PRODUCE THE SPL LISTED BELOW UNDER TEST CONDITIONS DESCRIBED IN TABLE 3.  
NOMINAL SENSITIVITY AT 1kHz IS dB RELATIVE TO 20µPa. ALL OTHER VALUES  
IN dB RELATIVE TO THE SENSITIVITY AT 1kHz.

FREQUENCY (Hz)	MINIMUM	NOMINAL	MAXIMUM
200	+1.5	+3.5	+5.5
500	0.0	+2.0	+4.0
1000	-2.0	102.5	+2.0
2000 - 3000	-1.0	+2.0	+5.0
4000	-12.0	---	---

PORT LOCATION: 12C

TABLE 1

TOTAL HARMONIC DISTORTION  
DEVICE WILL NOT EXCEED TOTAL HARMONIC DISTORTION LEVELS LISTED BELOW.

FREQUENCY (Hz)	AC DRIVE (V rms)	DC BIAS (mA)	LIMIT (%)
500	0.470	0	10
830	0.167	0	5
1250	0.167	0	5

TABLE 2

**TEST CONDITIONS**

NOMINAL SOURCE VOLTAGE	0.167 V rms, 0mA DC BIAS
SOURCE IMPEDANCE	<1 Ohm
TUBING	10mm [.394"] LONG, 1mm [.039"] I.D.
COUPLER CAVITY	2 CM <sup>3</sup> , SIMULATED ANSI S3.7 TYPE HA-3 (IEC 126)

TABLE 3

**ELECTRICAL**

DC RESISTANCE	48 OHMS ± 10%
IMPEDANCE @ 500 Hz	65 OHMS ± 15%
IMPEDANCE @ 1 kHz	100 OHMS ± 15%

TABLE 4

ISOLATION: CASE WILL BE ELECTRICALLY ISOLATED FROM THE COIL CIRCUIT.

TEMPERATURE: OPERATING RANGE FROM 0°C TO 63°C (SENSITIVITY WILL NOT VARY BY MORE THAN ±3 dB WITHIN RANGE)  
SENSITIVITY AT 0°C IS 2dB LOWER THAN THE SENSITIVITY AT ROOM TEMPERATURE.  
DELTA PEAK IS 1dB HIGHER AT BODY TEMPERATURE (37°C)  
STORAGE RANGE FROM -40°C TO 63°C.

Revision	C.O. #	Implementation Date	RELEASE LEVEL	REVISION
C	C10107990	11-20-08	Active	C
B	C10104212	5-1-06		
A	C10103609	2-2-06		

**KNOWLES ELECTRONICS**  
ITASCA, ILLINOIS U.S.A.

WHEN TEST LIMITS ARE USED TO ESTABLISH INCOMING INSPECTION ACCEPTANCE/REJECTION CRITERIA, CORRELATION OF TEST EQUIPMENT WITH KNOWLES IS ALSO REQUIRED FOR ELIMINATION OF EQUIPMENT AND TEST METHOD VARIATION

TITLE: **RECEIVER** **FED-26792-102**  
PERFORMANCE SPECIFICATION **SHT 2.1**

DR. BY	DATE
CRG	2-2-06
CK. BY	DATE
GJP	2-8-06
APP. BY	DATE
GJP	2-8-06