

THIS DRAWING IS SUPPLIED FOR INFORMATION ONLY. DESIGN FEATURES, SPECIFICATIONS AND PERFORMANCE DATA SHOWN HEREON ARE THE PROPERTY OF THE AMPHENOL CORPORATION. NO RIGHTS OF REPRODUCTION ARE IMPLIED. ALL DIMENSIONS ARE SUBJECT TO NORMAL MANUFACTURING VARIATIONS.

Customer Drawing

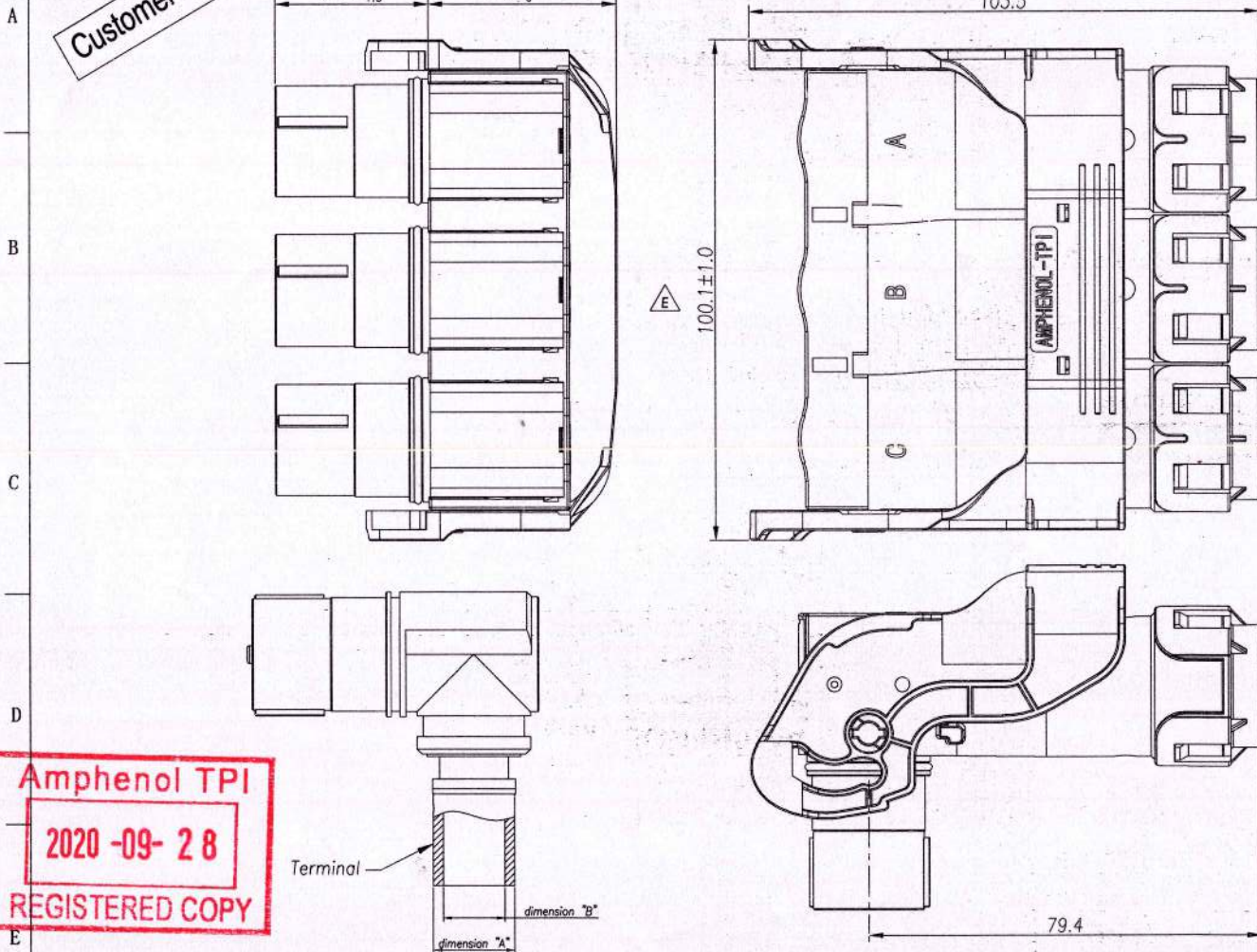

Amphenol TPI
2020-09-28
REGISTERED COPY

- 规格参数 (Spec.):
1. 工作温度 Operating temperature: $-40^{\circ}\text{C} \sim +125^{\circ}\text{C}$.
 2. 额定电流 Current rating (Connector Only): $35\text{mm}^2: 150\text{A}; 50\text{mm}^2: 200\text{A}; 70\text{mm}^2: 250\text{A}$.
 3. 额定电压 Operating voltage: 1000 VDC.
 4. 耐电压 Dielectric withstanding voltage: 5000 VDC.
 5. 防护等级 Protection class: IP67 & IP2X.
 6. 电磁屏蔽 Shielding.
 7. 机械寿命 Mating cycle: 100 Min.
 8. 带自动二次锁扣 Automatic secondary lock.
 9. 带高压互锁 Electrical interlock (HVIL).

订购信息 Ordering Information

PL28 3 X - 30 1 - 70 - 5		
键位及颜色 Key	高压互锁 HVIL	线缆大小 Cable Size
"X" Key	0, 不带互锁 No HVIL	*70"=70mm ²
"Y" Key	1, 带互锁 With HVIL	*50"=50mm ²
		*35"=35mm ²

REVISIONS						
REV	ZONE	ECO	DESCRIPTION	DATE	BY	APPR
A	--	--	INITIAL RELEASE	05/06/16	KC	GX
B	--	--	Update cable specifications	12/26/17	Sam	Penny
C	--	ECNG180802	Add Metal Cover And Sealing Ring	08/21/18	Fred	JL
D	--	ECNG180802	Update Spec	08/29/18	Fred	JL
E	--	ECNG191017	Change dimension tolerance	10/25/19	Steven	JL
F	--		Add Protection Cap	09/10/20	Steven	JL

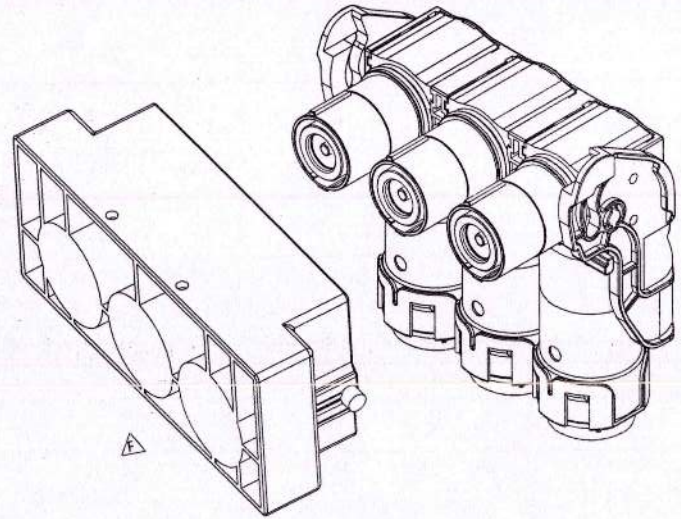

Standard Part List (With HVIL)

Model NO.	overall-diameter nominal (mm)	Dia Primary Insulation (mm)	outside-diameter of terminal (mm): "A"	inside-diameter of terminal (mm): "B"
PL283X-301-35-5	12.7±0.3	△9.7±0.3	△11.8±0.3	△8.8±0.3
PL283Y-301-35-5	12.7±0.3	△9.7±0.3	△11.8±0.3	△8.8±0.3
PL283X-301-50-5	14.9±0.3	△11.5±0.3	△14.5±0.3	△10.3±0.3
PL283Y-301-50-5	14.9±0.3	△11.5±0.3	△14.5±0.3	△10.3±0.3
PL283X-301-70-5	17.0±0.3	△13.7±0.3	△16.5±0.3	△12.5±0.3
PL283Y-301-70-5	17.0±0.3	△13.7±0.3	△16.5±0.3	△12.5±0.3

Standard Part List (Without HVIL)

Model NO.	overall-diameter nominal (mm)	Dia Primary Insulation (mm)	outside-diameter of terminal (mm): "A"	inside-diameter of terminal (mm): "B"
PL283X-300-35-5	12.7±0.3	△9.7±0.3	△11.8±0.3	△8.8±0.3
PL283Y-300-35-5	12.7±0.3	△9.7±0.3	△11.8±0.3	△8.8±0.3
PL283X-300-50-5	14.9±0.3	△11.5±0.3	△14.5±0.3	△10.3±0.3
PL283Y-300-50-5	14.9±0.3	△11.5±0.3	△14.5±0.3	△10.3±0.3
PL283X-300-70-5	17.0±0.3	△13.7±0.3	△16.5±0.3	△12.5±0.3
PL283Y-300-70-5	17.0±0.3	△13.7±0.3	△16.5±0.3	△12.5±0.3

		Amphenol Technical Products International Asia.				
		第三角投影 THIRD ANGLE PROJECTION	页码 SHEET 1 of 1	幅面 SIZE A3	版次 REV. F	比例 SCALE
签名 SIGNATURE		日期 DATE 09/10/20		UNLESS OTHERWISE SPECIFIED		DWG NO: PL283()-300-5
制图 DRAWN Steven		审核 CHECKED [Signature]		1) All dimensions are in metric (mm). 2) Tolerances are as follows: 0 PL DEC ±1.00 1 PL DEC ±0.50 2 PL DEC ±0.20		CUST PART #: N/A
批准 APPROVAL [Signature]				Angles ±1'		CUST REV. -

THIS DRAWING IS SUPPLIED FOR INFORMATION ONLY. DESIGN FEATURES, SPECIFICATIONS AND PERFORMANCE DATA SHOWN HEREON ARE THE PROPERTY OF THE AMPHENOL CORPORATION. NO RIGHTS OF REPRODUCTION ARE IMPLIED. ALL DIMENSIONS ARE SUBJECT TO NORMAL MANUFACTURING VARIATIONS.

Customer Drawing

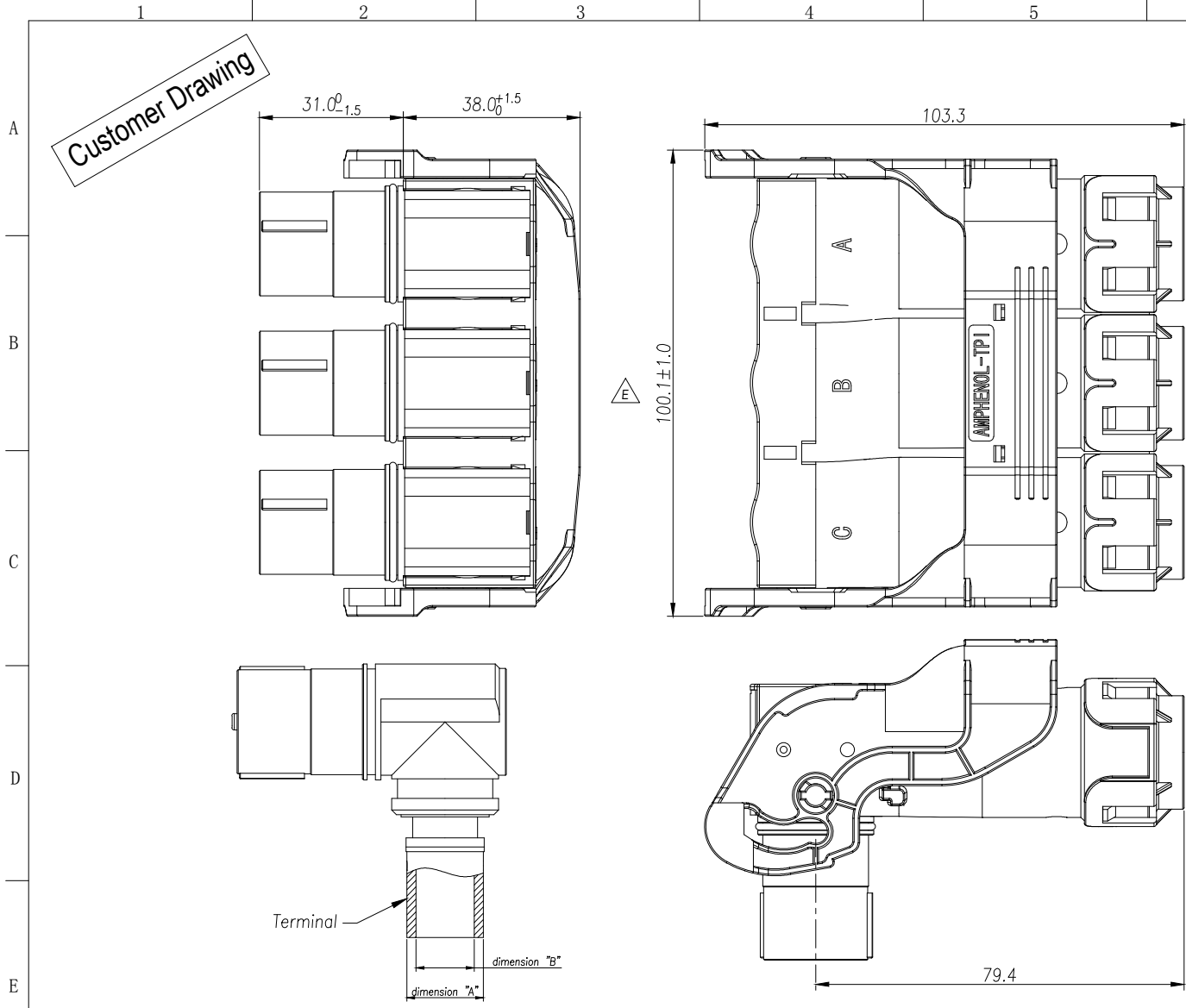

REVISIONS						
REV	ZONE	ECO	DESCRIPTION	DATE	BY	APPR
A	--	--	INITIAL RELEASE	05/06/16	KC	GX
B	--	--	Update cable specifications	12/26/17	Sam	Penny
C	--	ECNG180802	Add Metal Cover And Sealing Ring	08/21/18	Fred	JL
D	--	ECNG180802	Update Spec	08/29/18	Fred	JL
E	--	ECNG191017	Change dimension tolerance	10/25/19	Steven	JL
F	--		Add Protection Cap	09/10/20	Steven	JL

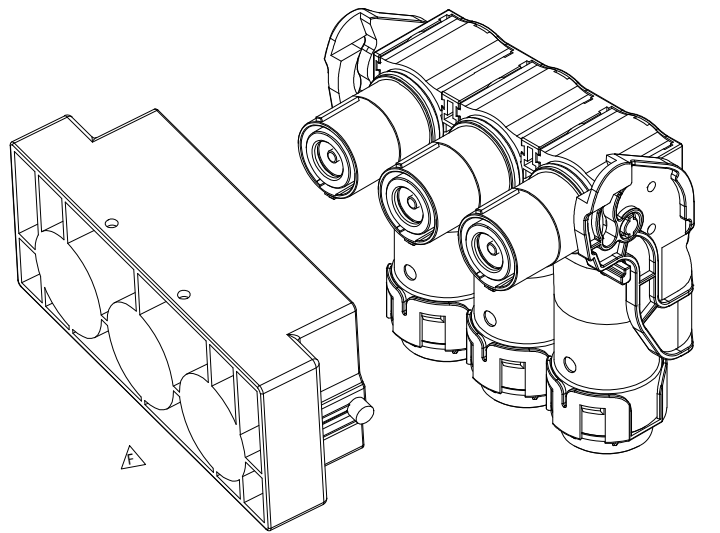

Standard Part List (With HVIL)

Model No.	overall-diameter nominal (mm)	Dia Primary Insulation (mm)	outside-diameter of terminal (mm): "A"	inside-diameter of terminal (mm): "B"
PL283X-301-35-5	12.7±0.3	△9.7±0.3	△11.8±0.3	△8.8±0.3
PL283Y-301-35-5	12.7±0.3	△9.7±0.3	△11.8±0.3	△8.8±0.3
PL283X-301-50-5	14.9±0.3	△11.5±0.3	△14.5±0.3	△10.3±0.3
PL283Y-301-50-5	14.9±0.3	△11.5±0.3	△14.5±0.3	△10.3±0.3
PL283X-301-70-5	17.0±0.3	△13.7±0.3	△16.5±0.3	△12.5±0.3
PL283Y-301-70-5	17.0±0.3	△13.7±0.3	△16.5±0.3	△12.5±0.3

Standard Part List (Without HVIL)

Model No.	overall-diameter nominal (mm)	Dia Primary Insulation (mm)	outside-diameter of terminal (mm): "A"	inside-diameter of terminal (mm): "B"
PL283X-300-35-5	12.7±0.3	△9.7±0.3	△11.8±0.3	△8.8±0.3
PL283Y-300-35-5	12.7±0.3	△9.7±0.3	△11.8±0.3	△8.8±0.3
PL283X-300-50-5	14.9±0.3	△11.5±0.3	△14.5±0.3	△10.3±0.3
PL283Y-300-50-5	14.9±0.3	△11.5±0.3	△14.5±0.3	△10.3±0.3
PL283X-300-70-5	17.0±0.3	△13.7±0.3	△16.5±0.3	△12.5±0.3
PL283Y-300-70-5	17.0±0.3	△13.7±0.3	△16.5±0.3	△12.5±0.3

规格参数 (Spec.):

- 工作温度 Operating temperature: -40° C~+125° C.
- 额定电流 Current rating (Connector Only): 35mm²: 150A; 50mm²: 200A; 70mm²: 250A.
- 额定电压 Operating voltage: 1000 VDC.
- 耐电压 Dielectric withstanding voltage: 5000 VDC.
- 防护等级 Protection class: IP67 & IP2X.
- 电磁屏蔽 Shielding.
- 机械寿命 Mating cycle: 100 Min.
- 带自动二次锁扣 Automatic secondary lock.
- 带高压互锁 Electrical interlock (HVIL).

订购信息 Ordering Information

PL28 3 X - 30 1 - 70 - 5

键位及颜色 Key "X" Key "Y" Key	高压互锁 HVIL 0, 不带互锁 No HVIL 1, 带互锁 With HVIL	线缆大小 Cable Size "70"=70mm ² "50"=50mm ² "35"=35mm ²
---------------------------------	--	---

		Amphenol Technical Products International Asia.				PART NAME: PwrLok 10mm-90 3POS Plug Conn	
		第三角投影 THIRD ANGLE PROJECTION	页面 SHEET	幅面 SIZE	版次 REV.	比例 SCALE	DWG NO: PL283()-300-5
签名 SIGNATURE: Steven 制图 DRAWN: Steven 审核 CHECKED: 批准 APPROVAL:		日期 DATE: 09/10/20		UNLESS OTHERWISE SPECIFIED 1) All dimensions are in metric (mm). 2) Tolerances are as follows: 0 PL DEC ±1.00 1 PL DEC ±0.50 2 PL DEC ±0.20		Angles ±1° CUST REV.: -	