



# MMDT3946

## COMPLEMENTARY NPN/PNP GENERAL PURPOSE SWITCHING TRANSISTOR

<b>VOLTAGE</b>	<b>40 Volt</b>	<b>POWER</b>	<b>225 mWatt</b>
----------------	----------------	--------------	------------------

### FEATURES

- Epitaxial silicon, planar design
- Collector-emitter voltage  $V_{CE} = 40V$
- Collector current  $I_c = 200mA$
- Transition Frequency  $> 300MHz$   $f_T @ I_c=10mA, V_{CE}=20V, f=100MHz$
- Lead free in compliance with EU RoHS 2011/65/EU directive
- Green molding compound as per IEC61249 Std. . (Halogen Free)

### MECHANICAL DATA

- Case: SOT-363, Plastic
- Terminals: Solderable per MIL-STD-750, Method 2026
- Approx. Weight: 0.0002 ounces, 0.006 grams
- Marking: S3A

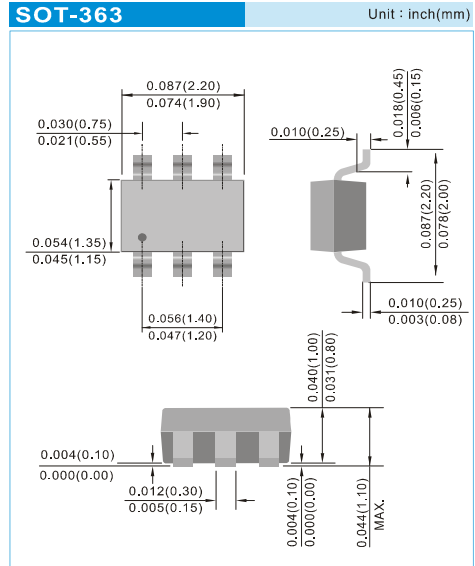
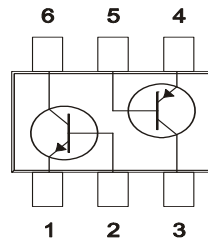

### ABSOLUTE RATINGS

ABSOLUTE RATING		NPN 3904 SECTION	PNP 3906 SECTION	-
PARAMETER	SYMBOL	VALUE	VALUE	UNITS
Collector - Emitter Voltage	$V_{CEO}$	40	-40	V
Collector - Base Voltage	$V_{CBO}$	60	-40	V
Emitter - Base Voltage	$V_{EBO}$	6	-5	V
Collector Current - Continuous	$I_c$	200	-200	mA

### THERMAL CHARACTERISTICS

PARAMETER	SYMBOL	VALUE	UNITS
Max Power Dissipation (Note 1)	$P_{TOT}$	225	mW
Thermal Resistance , Junction to Ambient	$R_{\theta JA}$	625	$^{\circ}C/W$
Junction Temperature	$T_J$	-55 to 150	$^{\circ}C$
Storage Temperature	$T_{STG}$	-55 to 150	$^{\circ}C$

Note 1: Transistor mounted on FR-5 board 1 x 0.75 x 0.062 in.



# MMDT3946

## ELECTRICAL CHARACTERISTICS NPN SECTION

PARAMETER	SYMBOL	TEST CONDITION	MIN.	TYP.	MAX.	UNITS
Collector - Emitter Breakdown Voltage	$V_{(BR)CEO}$	$I_C=1.0mA, I_B=0$	40	-	-	V
Collector - Base Breakdown Voltage	$V_{(BR)CBO}$	$I_C=10\mu A, I_E=0$	60	-	-	V
Emitter - Base Breakdown Voltage	$V_{(BR)EBO}$	$I_E=10\mu A, I_C=0$	6.0	-	-	V
Base Cutoff Current	$I_{BI}$	$V_{CE}=30V, V_{EB}=3.0V$	-	-	50	nA
Collector Cutoff Current	$I_{CEX}$	$V_{CE}=30V, V_{EB}=3.0V$	-	-	50	nA
DC Current Gain (Note 2)	$h_{FE}$	$I_C=0.1mA, V_{CE}=1.0V$ $I_C=1.0mA, V_{CE}=1.0V$ $I_C=10mA, V_{CE}=1.0V$ $I_C=50mA, V_{CE}=1.0V$ $I_C=100mA, V_{CE}=1.0V$	40 70 100 60 30	- - - - -	- - 300 - -	-
Collector - Emitter Saturation Voltage (Note 2)	$V_{CE(SAT)}$	$I_C=10mA, I_B=1.0mA$ $I_C=50mA, I_B=5.0mA$	-	-	0.2 0.3	V
Base - Emitter Saturation Voltage (Note 2)	$V_{BE(SAT)}$	$I_C=10mA, I_B=1.0mA$ $I_C=50mA, I_B=5.0mA$	0.65 -	- -	0.85 0.95	V
Collector - Base Capacitance	$C_{CBO}$	$V_{CB}=5V, I_E=0, f=1MHz$	-	-	4.0	pF
Emitter - Base Capacitance	$C_{EBO}$	$V_{CB}=0.5V, I_C=0, f=1MHz$	-	-	8.0	pF
Delay Time	$t_d$	$V_{CC}=3V, V_{BE}=-0.5V,$ $I_C=10mA, I_B=1.0mA$	-	-	35	ns
Rise Time	$t_r$	$V_{CC}=3V, V_{BE}=-0.5V,$ $I_C=10mA, I_B=1.0mA$	-	-	35	ns
Storage Time	$t_s$	$V_{CC}=3V, I_C=10mA$ $I_{B1}=I_{B2}=1.0mA$	-	-	200	ns
Fall Time	$t_f$	$V_{CC}=3V, I_C=10mA$ $I_{B1}=I_{B2}=1.0mA$	-	-	50	ns

Note 2: Pulse Test: Pulse Width < 300 us, Duty Cycle < 2.0%.

### SWITCHING TIME EQUIVALENT TEST CIRCUITS

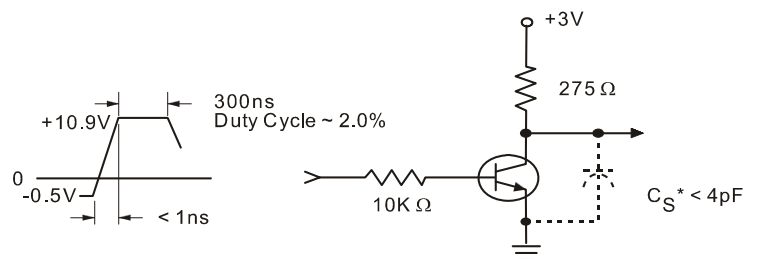

Delay and Rise Time Equivalent Test Circuit

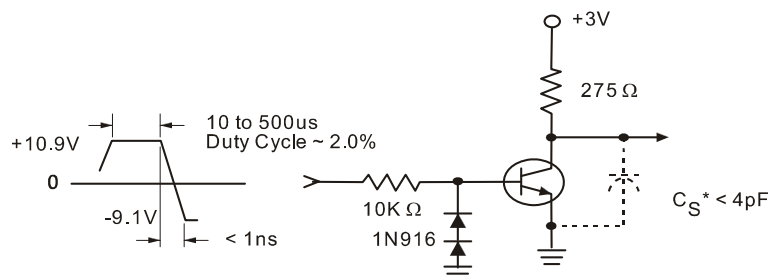

Storage and Fall Time Equivalent Test Circuit



# MMDT3946

## ELECTRICAL CHARACTERISTICS PNP SECTION

PARAMETER	SYMBOL	TEST CONDITION	MIN.	TYP.	MAX.	UNITS
Collector - Emitter Breakdown Voltage	$V_{(BR)CEO}$	$I_C = -1.0\text{mA}, I_B = 0$	-40	-	-	V
Collector - Base Breakdown Voltage	$V_{(BR)CBO}$	$I_C = -10\mu\text{A}, I_E = 0$	-40	-	-	V
Emitter - Base Breakdown Voltage	$V_{(BR)EBO}$	$I_E = -10\mu\text{A}, I_C = 0$	-5.0	-	-	V
Base Cutoff Current	$I_{BI}$	$V_{CE} = -30\text{V}, V_{EB} = -3.0\text{V}$	-	-	-50	nA
Collector Cutoff Current	$I_{CEX}$	$V_{CE} = -30\text{V}, V_{EB} = -3.0\text{V}$	-	-	-50	nA
DC Current Gain (Note 2)	$h_{FE}$	$I_C = -0.1\text{mA}, V_{CE} = -1.0\text{V}$ $I_C = -1.0\text{mA}, V_{CE} = -1.0\text{V}$ $I_C = -10\text{mA}, V_{CE} = -1.0\text{V}$ $I_C = -50\text{mA}, V_{CE} = -1.0\text{V}$ $I_C = -100\text{mA}, V_{CE} = -1.0\text{V}$	60 80 100 60 30	- - - - -	- - 300 - -	-
Collector - Emitter Saturation Voltage (Note 2)	$V_{CE(SAT)}$	$I_C = -10\text{mA}, I_B = -1.0\text{mA}$ $I_C = -50\text{mA}, I_B = -5.0\text{mA}$	-	-	-0.25 -0.4	V
Base - Emitter Saturation Voltage (Note 2)	$V_{BE(SAT)}$	$I_C = -10\text{mA}, I_B = -1.0\text{mA}$ $I_C = -50\text{mA}, I_B = -5.0\text{mA}$	-0.65 -	- -	-0.85 -0.95	V
Collector - Base Capacitance	$C_{CBO}$	$V_{CB} = -5\text{V}, I_E = 0, f = 1\text{MHz}$	-	-	4.0	pF
Emitter - Base Capacitance	$C_{EBO}$	$V_{CB} = -0.5\text{V}, I_C = 0, f = 1\text{MHz}$	-	-	10	pF
Delay Time	$t_d$	$V_{CC} = -3\text{V}, V_{BE} = -0.5\text{V},$ $I_C = -10\text{mA}, I_B = -1.0\text{mA}$	-	-	35	ns
Rise Time	$t_r$	$V_{CC} = -3\text{V}, V_{BE} = -0.5\text{V},$ $I_C = -10\text{mA}, I_B = -1.0\text{mA}$	-	-	35	ns
Storage Time	$t_s$	$V_{CC} = -3\text{V}, I_C = -10\text{mA}$ $I_{B1} = I_{B2} = -1.0\text{mA}$	-	-	225	ns
Fall Time	$t_f$	$V_{CC} = -3\text{V}, I_C = -10\text{mA}$ $I_{B1} = I_{B2} = 1.0\text{mA}$	-	-	75	ns

### SWITCHING TIME EQUIVALENT TEST CIRCUITS

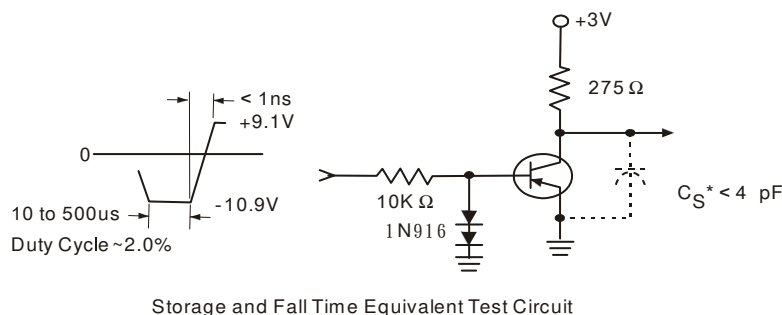
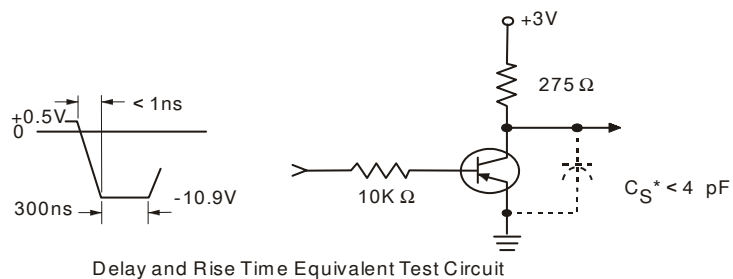



# MMDT3946

## ELECTRICAL CHARACTERISTICS CURVE NPN SECTION

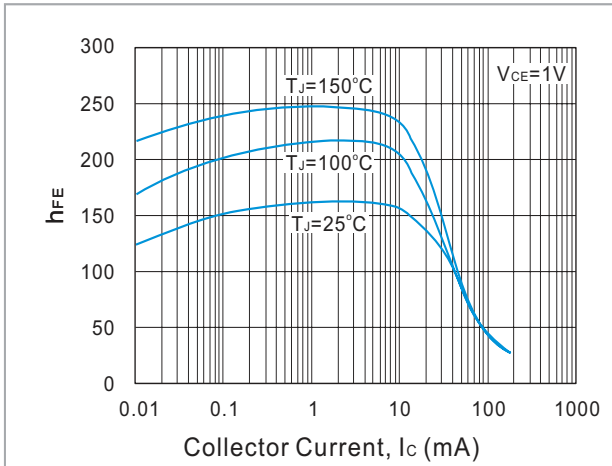

**Fig. 1. Typical  $h_{FE}$  vs. Collector Current**

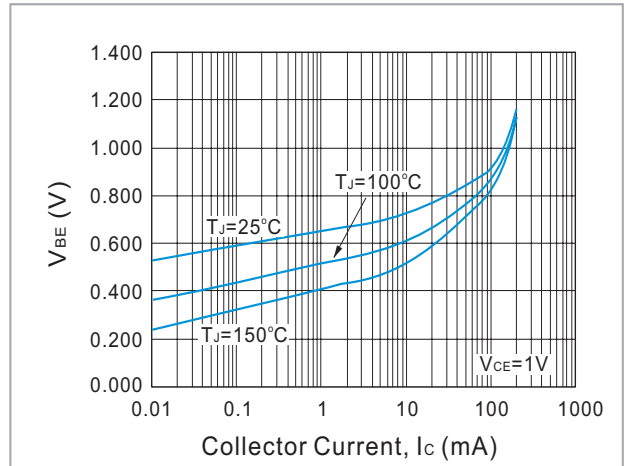

**Fig. 2. Typical  $V_{BE}$  vs. Collector Current**

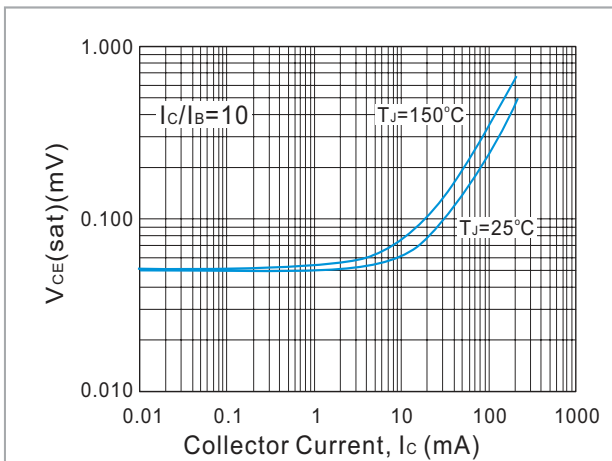

**Fig. 3. Typical  $V_{CE(sat)}$  vs. Collector Current**

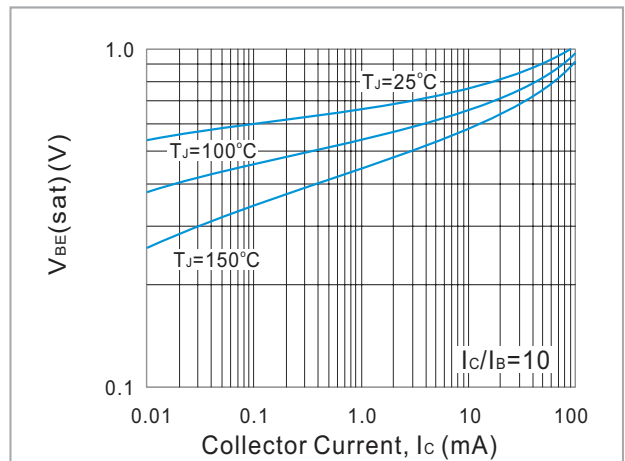

**Fig. 4. Typical  $V_{BE(sat)}$  vs Collector Current**

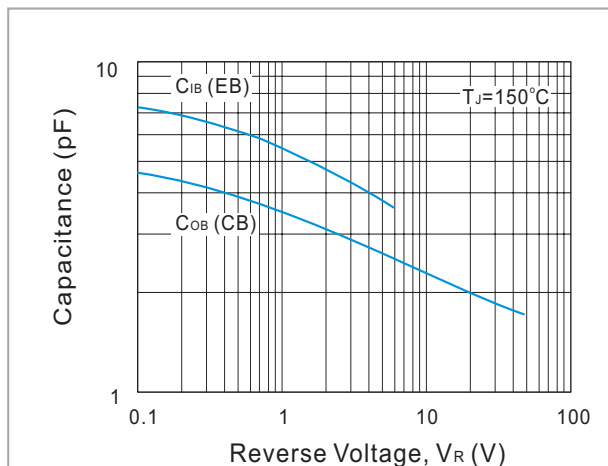
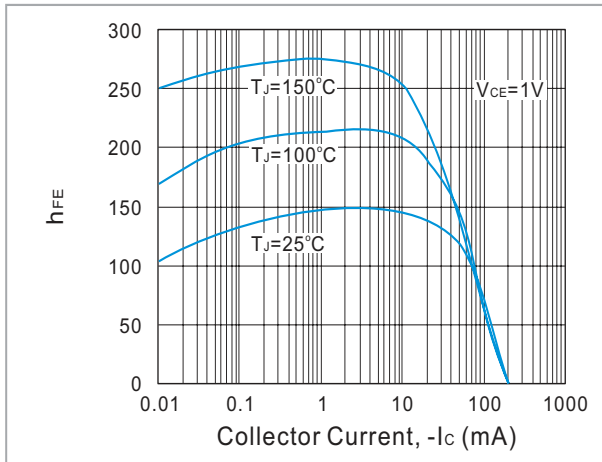

**Fig. 5. Typical Capacitances vs. Reverse Voltage**



# MMDT3946

## ELECTRICAL CHARACTERISTICS CURVE PNP SECTION



**Fig. 1. Typical  $h_{FE}$  vs Collector Current**

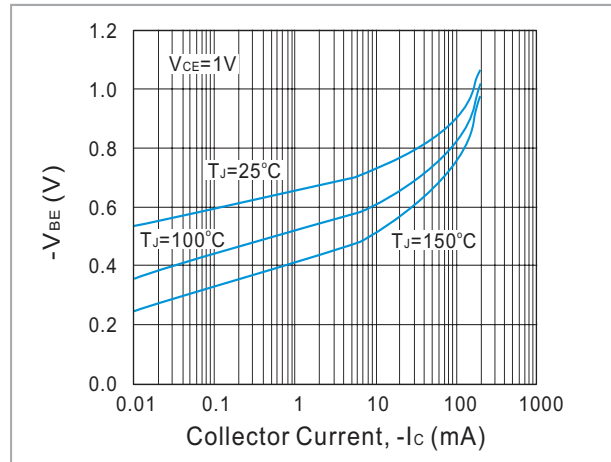

**Fig. 2. Typical  $V_{BE}$  vs Collector Current**

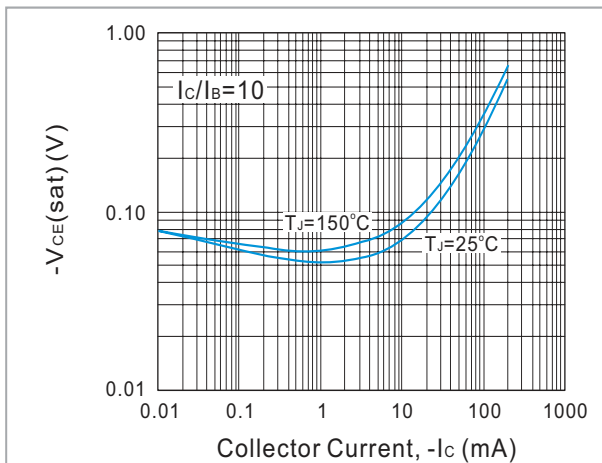

**Fig. 3. Typical  $V_{CE(sat)}$  vs Collector Current**

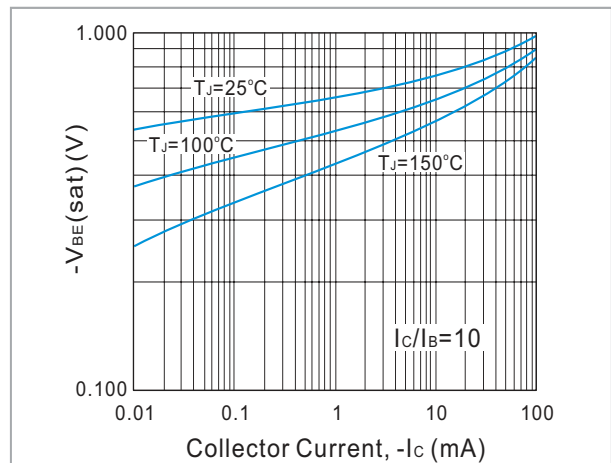

**Fig. 4. Typical  $V_{BE(sat)}$  vs Collector Current**

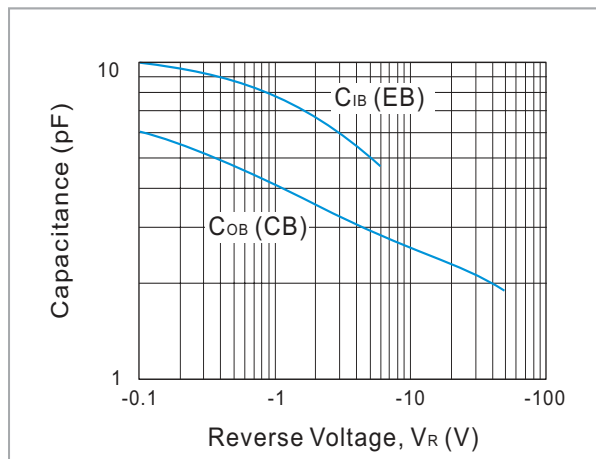

**Fig. 5. Typical Capacitances vs Reverse Voltage**



# MMDT3946

## MOUNTING PAD LAYOUT

**SOT-363**

Unit : inch(mm)

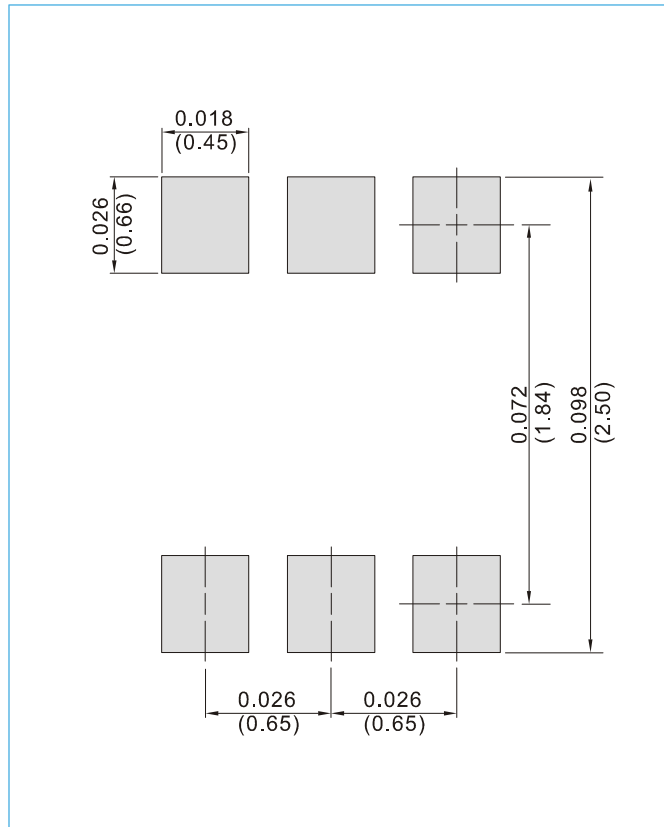

## ORDER INFORMATION

- Packing information
  - T/R - 10K per 13" plastic Reel
  - T/R - 3K per 7" plastic Reel



# MMDT3946

## Part No\_packing code\_Version

MMDT3946\_R1\_00001

MMDT3946\_R2\_00001

For example :

**RB500V-40\_R2\_00001**

Part No.

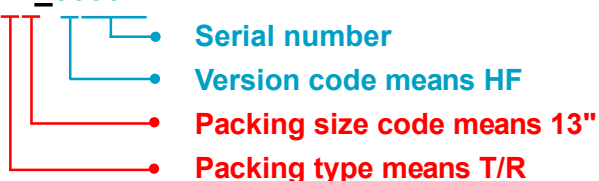

Packing Code <b>XX</b>				Version Code <b>XXXXX</b>		
Packing type	1 <sup>st</sup> Code	Packing size code	2 <sup>nd</sup> Code	HF or RoHS	1 <sup>st</sup> Code	2 <sup>nd</sup> ~5 <sup>th</sup> Code
Tape and Ammunition Box (T/B)	<b>A</b>	N/A	<b>0</b>	HF	<b>0</b>	serial number
Tape and Reel (T/R)	<b>R</b>	7"	<b>1</b>	RoHS	<b>1</b>	serial number
Bulk Packing (B/P)	<b>B</b>	13"	<b>2</b>			
Tube Packing (T/P)	<b>T</b>	26mm	<b>X</b>			
Tape and Reel (Right Oriented) (TRR)	<b>S</b>	52mm	<b>Y</b>			
Tape and Reel (Left Oriented) (TRL)	<b>L</b>	PANASERT T/B CATHODE UP (PBCU)	<b>U</b>			
FORMING	<b>F</b>	PANASERT T/B CATHODE DOWN (PBCD)	<b>D</b>			



## MMDT3946

---

### Disclaimer

- Reproducing and modifying information of the document is prohibited without permission from Panjit International Inc..
- Panjit International Inc. reserves the rights to make changes of the content herein the document anytime without notification. Please refer to our website for the latest document.
- Panjit International Inc. disclaims any and all liability arising out of the application or use of any product including damages incidentally and consequentially occurred.
- Panjit International Inc. does not assume any and all implied warranties, including warranties of fitness for particular purpose, non-infringement and merchantability.
- Applications shown on the herein document are examples of standard use and operation. Customers are responsible in comprehending the suitable use in particular applications. Panjit International Inc. makes no representation or warranty that such applications will be suitable for the specified use without further testing or modification.
- The products shown herein are not designed and authorized for equipments requiring high level of reliability or relating to human life and for any applications concerning life-saving or life-sustaining, such as medical instruments, transportation equipment, aerospace machinery et cetera. Customers using or selling these products for use in such applications do so at their own risk and agree to fully indemnify Panjit International Inc. for any damages resulting from such improper use or sale.
- Since Panjit uses lot number as the tracking base, please provide the lot number for tracking when complaining.