

NOTES: UNLESS OTHERWISE SPECIFIED

1. CONSTRUCTION:
 SLIDE: NICKEL SILVER
 CONTACT BLADE: NICKEL SILVER
 SPRING: STAINLESS STEEL
2. PERFORMANCE:
 MAXIMUM CURRENT: 5 AMPS
 MAXIMUM VOLTAGE: 0 V
 MAXIMUM TEMPERATURE: 500°F (260°C)
3. INSTALLATION TOOL P/N T-20

		REVISIONS		DATE	APPROVED
LTR	DESCRIPTION				

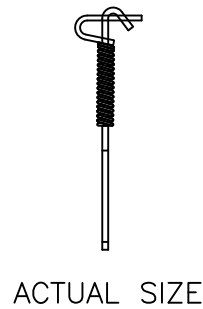
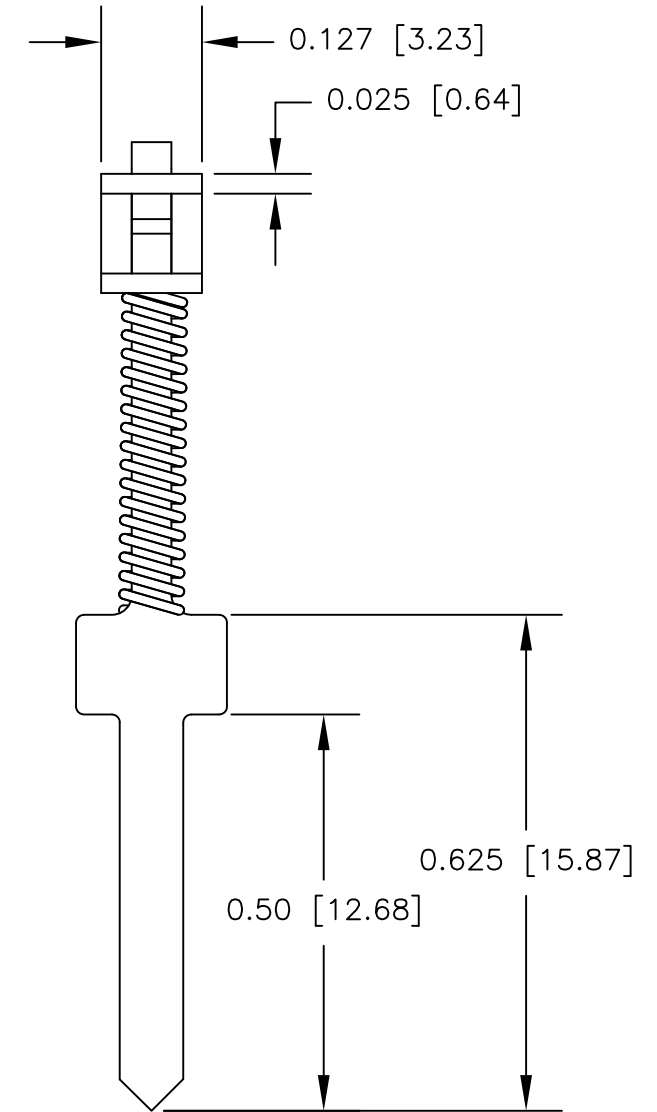
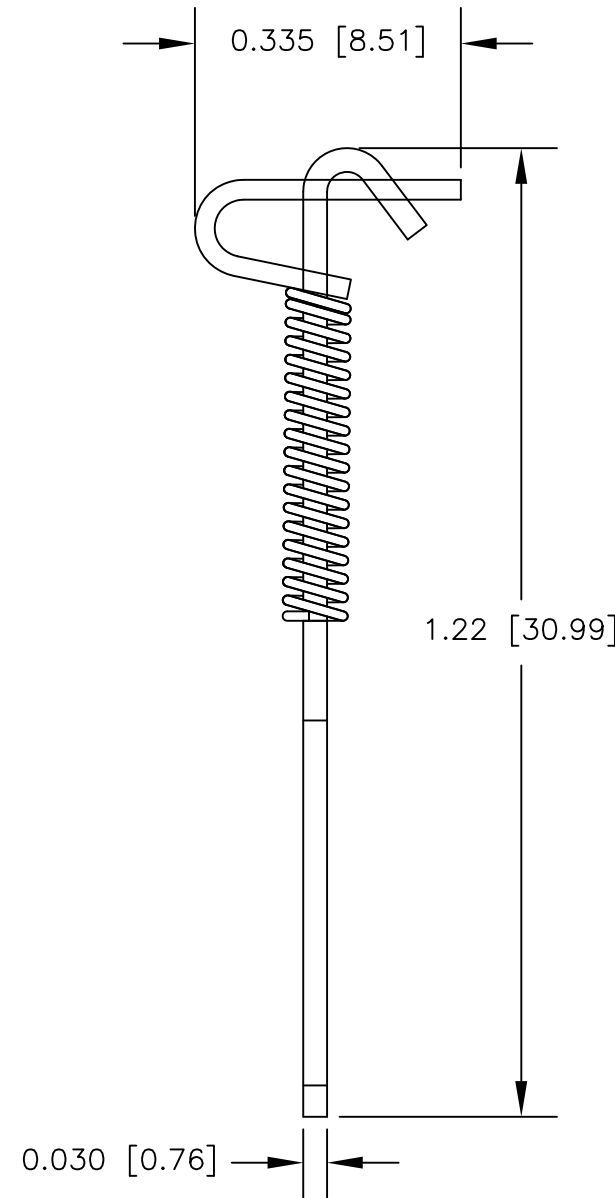
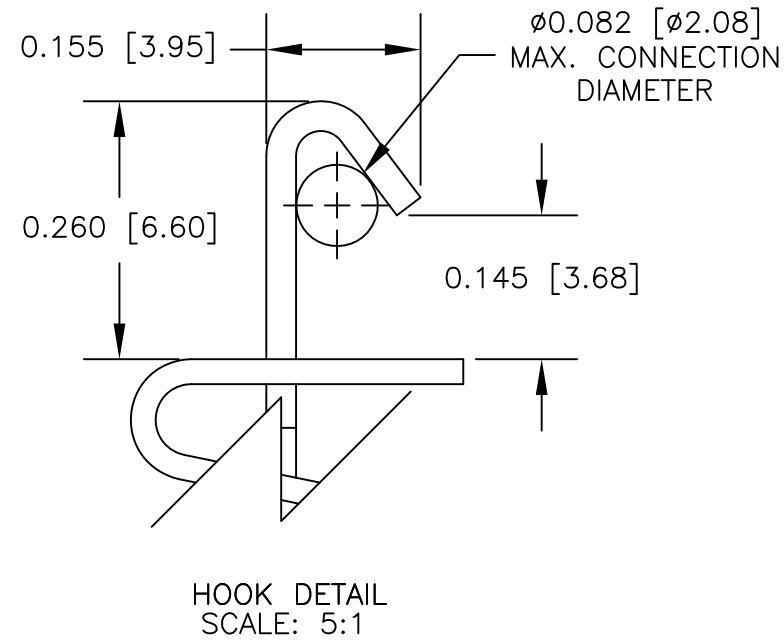

		UNLESS OTHERWISE SPECIFIED DIMENSIONS ARE IN INCHES TOLERANCES ARE: FRACTIONS DECIMALS ANGLES ± .XX ± ± .XXX ±	CONTRACT NO.		E-Z-HOOK DIVISION OF TEKTEST INC. ARCADIA, CA 91006 U.S.A.	
			APPROVALS	DATE		
		MATERIAL SEE NOTE.	DRAWN	S.B.W.	10/04	
			APPROVED BY			
		FINISH SEE NOTE.	DESCRIPTION		ALL METAL TEST CLIP FOR HIGH TEMPERATURE RISE	
NEXT ASSY	USED ON		SIZE	CODE IDENT NO.		DRAWING NO.
APPLICATION		DO NOT SCALE DRAWING	B	08505	84-1	
			SCALE	4:1	SHEET 1 OF 1	