

DATE	REV	ECN	APP'D. BY
3-27-17	A6	10957	TRM
4-20-17	A7	10983	TRM

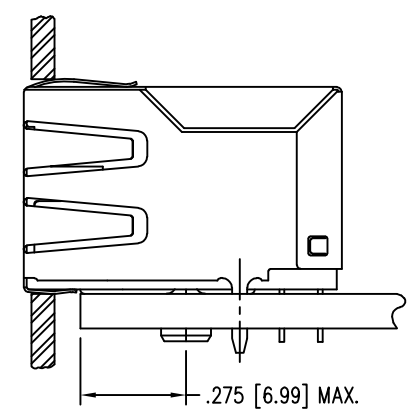
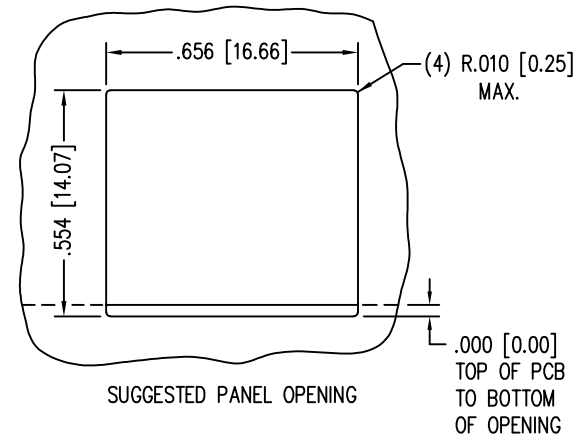
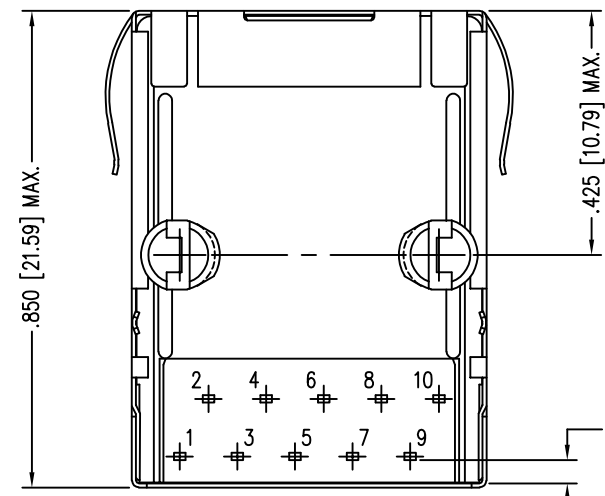
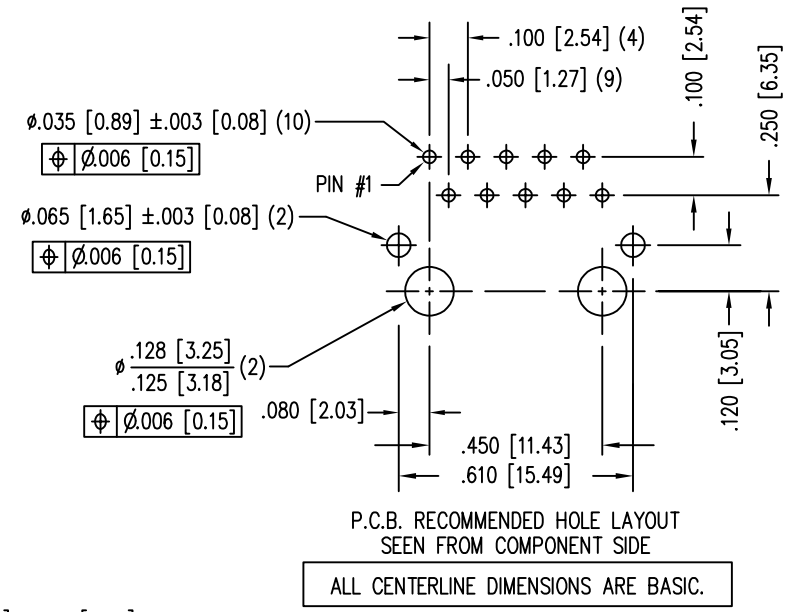
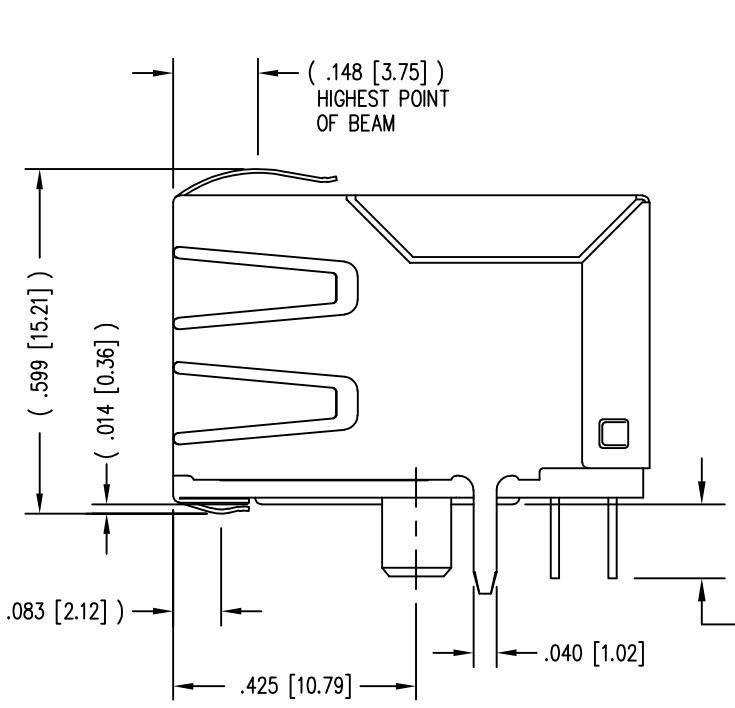
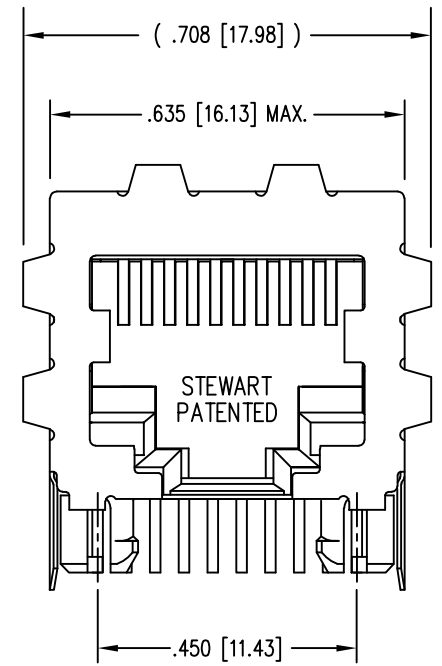

- NOTES:
- CONNECTOR MATERIALS:  
HOUSING: THERMOPLASTIC UL94 V-0  
CONTACTS/SHIELD: COPPER ALLOY  
SHIELD PLATING: NICKEL WITH TIN PLATED SOLDER TAILS.  
CONTACT PLATING: SELECTIVE GOLD IN CONTACT AREA  
SEE CHART FOR PART NUMBER
  - FOR PRODUCT SPECIFICATIONS SEE PRO22-01.
  - DIMENSIONS AND TOLERANCES COMPLY WITH TIA-1096 STANDARD.
  - THE SUGGESTED PANEL OPENING IS INTENDED TO GIVE USER THE ABILITY TO HAVE REASONABLE JACK/PANEL CLEARANCES, YET MAINTAIN GROUNDING CAPABILITY. THESE VARIABLES CAN BE ADJUSTED IN EITHER DIRECTION BUT MAY CARRY SOME CONSEQUENCES IN THE FORM OF LOWER MATING FORCES OR TIGHTER ASSEMBLY TOLERANCES.

30 MICRO-INCHES [0.76um]	SS-641010S-A-PG4-BA
CONTACT PLATING IN MATING AREA	PART NUMBER

B

B

A

A

THIRD ANGLE PROJECTION	 1118 Susquehanna Trail South Glen Rock, PA 17327-9199 (717) 235-7512 <a href="http://www.stewartconnector.com">http://www.stewartconnector.com</a>
DO NOT SCALE DRAWING DRAWING IS SUBJECT TO CHANGE WITHOUT NOTICE	
DIMENSIONS: INCHES [METRIC]	TITLE: TEN CONDUCTOR / TEN POSITION JACK, EMI-RFI ONE PIECE SHIELDED, ESD GROUNDED
UNLESS OTHERWISE SPECIFIED TOLERANCES ARE $\pm .005 [0.13]$ ANGLES ARE $\pm 1^\circ$	DRN BY: KRL DATE: 1/30/06
SHEET NO. 1 OF 1	APP'D BY: JM DATE: 1-31-06
	DWG NO. CT640206 REV. A7

