

## 3-Port HDMI™ Signal Switch with I<sup>2</sup>C Control

### Features

- 3:1 HDMI™ Switch Mux
- Non-Blocking EQ path for ideal EQ control in main Receiver chipset
- -3dB bandwidth up to 5Gbps to support HDMI 1.3a (16-bit color depth per channel)
- HDMI 1.4 data rate ready
- DDC active signal buffer or passive switch selectable
- I<sup>2</sup>C Register control for switch configuration
- Automatic HDCP reset circuitry for quick communication when switching from one port to another
- HPD polarity control and signal trigger through I<sup>2</sup>C register setting
- Connector Plug-in detection and Interrupt Flag setting
- Selectable HPD 5V signal level shifter with open drain output stage or output buffer
- 3.3V power supply and standby power supply
- TMDS output enable control
- Low power consumption to support Energy Star Compliance
- ESD protection on all I/O pins
  - 8kV contact per IEC61000-4-2, level 4
- Packaging (Pb-free & Green available):
  - 80-contact LQFP

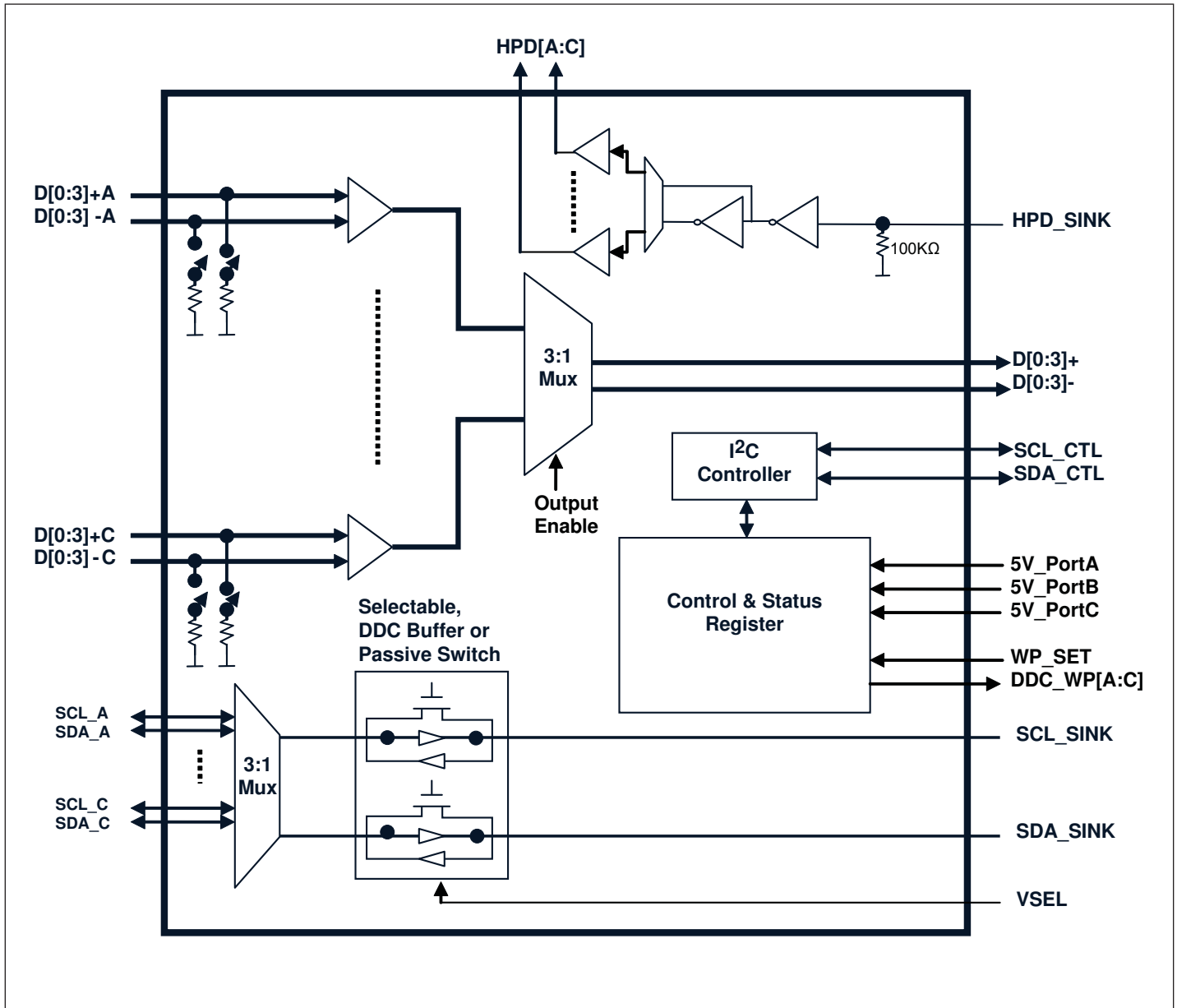
### Description

Pericom Semiconductor's PI3HDMI series of switch circuits are targeted for high-resolution video networks that are based on DVI/HDMI™ standards. The PI3HDMI2310 is a 3-to-1 HDMI Mux/DeMux signal switch. It is designed for low bit-to-bit skew and high channel-to-channel noise isolation. The maximum data rate support is up to 5Gbps which can meet HDMI 1.3a standard and support the resolution requirement of next generation HDTV and PC graphics.

PI3HDMI2310 is designed specifically for ATC-Sink requirements. All switch control settings are through I<sup>2</sup>C bus to provide flexible design and reducing peripheral components. Selectable active signal buffer for DDC bus can optimize the bi-directional data transmission for long trace or cable applications.

All input pins are protected with Pericom's ESD protection circuits supporting ESD damage as high as 8kV contact per IEC61000-4-2 Level 4 specification.

**Block Diagram**





### Pinout Table

Pin Name	I/O Type	Description
V <sub>DD</sub>	I/O	3.3V power supply. When V <sub>DD</sub> is off, the TMDS channels will be powered down.
SV <sub>DD</sub>	I/O	3.3V standby power supply. SV <sub>DD</sub> is for all side band signals, I <sup>2</sup> C register and I <sup>2</sup> C bus.
HPD_SINK	I	Sink side hot plug detector input. High: 5-V power signal asserted from source to sink and EDID is ready. Low: No 5-V power signal asserted from source to sink, or EDID is not ready.
HPD_A	O	Port A HPD output
HPD_B	O	Port B HPD output
HPD_C	O	Port C HPD output
D0+A D0-A D1+A D1-A D2+A D2-A D3+A D3-A	I	Port A TMDS inputs
D0+B D0-B D1+B D1-B D2+B D2-B D3+B D3-B	I	Port B TMDS inputs
D0+C D0-C D1+C D1-C D2+C D2-C D3+C D3-C	I	Port C TMDS inputs

Pin Name	I/O Type	Description
D0+ D0- D1+ D1- D2+ D2- D3+ D3-	O	TMDS outputs
SCL_A	I/O	Port A DDC Clock
SCL_B	I/O	Port B DDC Clock
SCL_C	I/O	Port C DDC Clock
SDA_A	I/O	Port A DDC Data
SDA_B	I/O	Port B DDC Data
SDA_C	I/O	Port C DDC Data
SCL_SINK	I/O	Sink side DDC Clock
SDA_SINK	I/O	Sink side DDC Data
SCL_CTL	I/O	I <sup>2</sup> C Clock
SDA_CTL	I/O	I <sup>2</sup> C Data
WP_SET	I	WP_SET = 0 (Default), Set B1b[1] as INT Flag. WP_SET = 1, DDC_WP[A:C] is programmable by B1b[1].
DDC_WPA, DDC_WPB, DDC_WPC	O	Open drain output. When WP_SET = 1, general purpose logic configured by B1b[1]
$\overline{OE}$	I	Output Enable control. Active low.
A1	I	I <sup>2</sup> C Address 1
A0	I	I <sup>2</sup> C Address 0
5V_PortA, 5V_PortB, 5V_PortC	I	Connector 5V port.
VSEL	I	DDC buffer V <sub>IL</sub> selection. VSEL = 0V, V <sub>IL</sub> = 0.5V VSEL = 0.5 V <sub>DD</sub> , V <sub>IL</sub> =0.45V VSEL = V <sub>DD</sub> , V <sub>IL</sub> =0.6V

### Truth Table

WP_SET	B1_b[1]	DDC_WP[A:C]
1	0	Hi_Z
1	1	0
0	X	Hi_Z

### I<sup>2</sup>C Control Register

	b7	b6	b5	b4	b3	b2	b1	b0
Address Byte	1	0	1	0	1	A1 Hardware Selectable	A0 Hardware Selectable	0/1 *

\* 0:Write; 1:Read

### Data Byte 0: Control Register

Bit	Description	Type	Power Up Condition	Logic Settings
7	HDMI input port selection	W	0	00 = Port A 01 = Port B
6	HDMI input port selection	W	0	10 = Port C 11 = Not Defined
5	HPD Logic Selection	W	1	0 = Inverted 1 = Non Inverted
4	HPD Input Selection	RW	0	0 = HPD_SINK 1 = I <sup>2</sup> C Register Setting B0b[2:0]
3	-	-	-	-
2	HPD Port C Logic Setting	W	0	I. Byte0 b[4] = 1 HPD Port C Register setting II. Byte0 b[4] = 0 Test mode
1	HPD Port B Logic Setting	W	0	I. Byte0 b[4] = 1 HPD Port B Register setting II. Byte0 b[4] = 0 Test mode
0	HPD Port A Logic Setting	W	0	I. Byte0 b[4] = 1 HPD Port A Register setting II. Byte0 b[4] = 0 Test mode

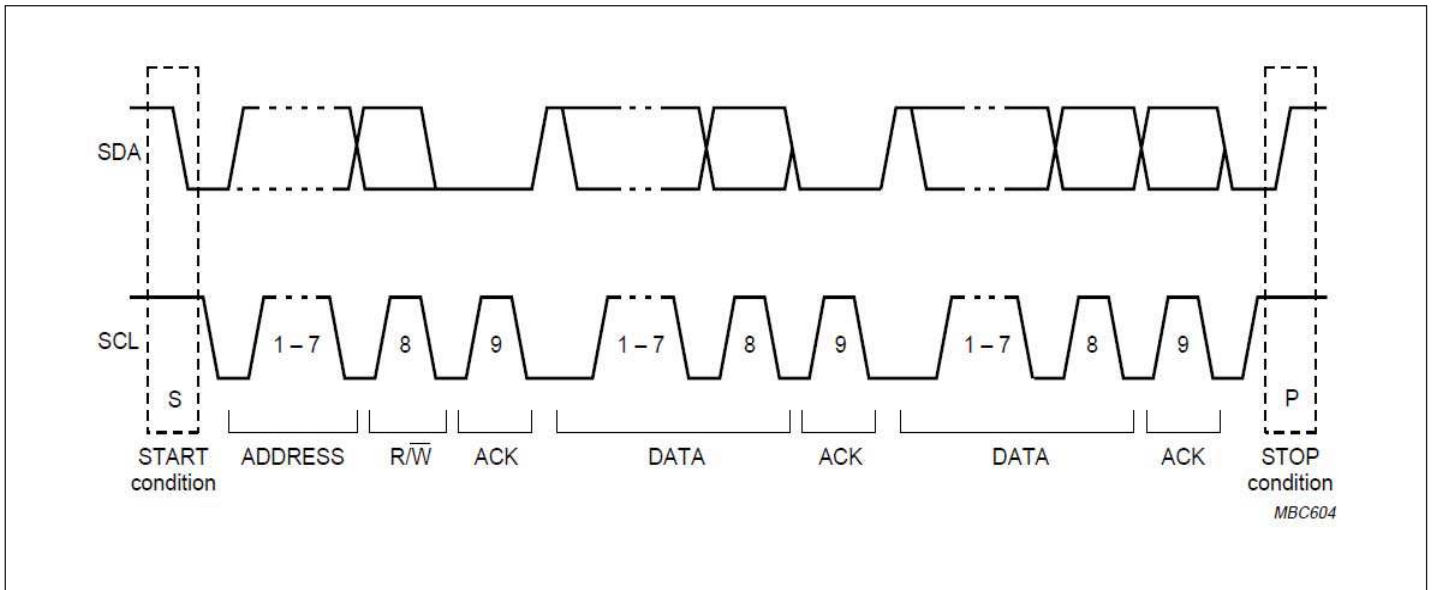
### Data Byte 1: Control Register

Bit	Description	Type	Power Up Condition	Logic Settings
7	HPD Output Stage selection	W	0	0 = Open Drain 1 = Output Buffer
6	Output Enable	W	1	0 = Output Disable (also drives switch into power down mode) 1 = Output Enable
5	-	-	-	-
4	5V_Port C connect	R	0	0 = Disconnected 1 = Connected; Set INT Flag
3	5V_Port B connect	R	0	0 = Disconnected 1 = Connected; Set INT Flag
2	5V_Port A connect	R	0	0 = Disconnected 1 = Connected; Set INT Flag
1	INT Flag	R/W	0	When WP_SET = 0, B1b[1] is configured as INT flag. 0 = INT Flag Clear 1 = INT Flag Set When WP_SET = 1, B1b[1] is configured as DDC_WP input setting.
0	DDC channel selection	W	0	0 = Passive switch 1 = Active switch buffer

\* External hardware control pin WP\_SET will set B1b1 to be INT Flag or DDC\_WP[A:C] input.

**Bus transactions**

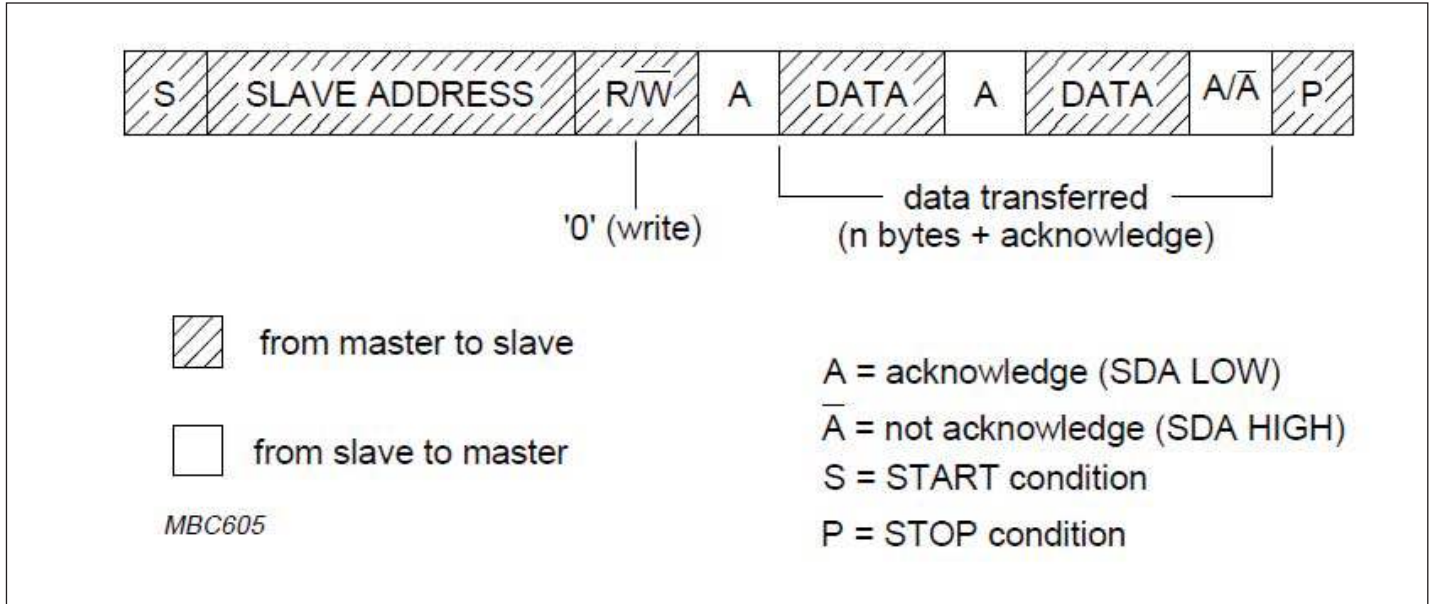
Data transfers follow the format shown in Fig.1. After the START condition (S), a slave address is sent. This address is 7 bits long followed by an eighth bit which is a data direction bit (R/W) - a 'zero' indicates a transmission (WRITE), a 'one' indicates a request for data (READ). A data transfer is always terminated by a STOP condition (P) generated by the master. However, if a master still wishes to communicate on the bus, it can generate a repeated START condition (Sr) and address another slave without first generating a STOP condition. Various combinations of read/write formats are then possible within such a transfer.



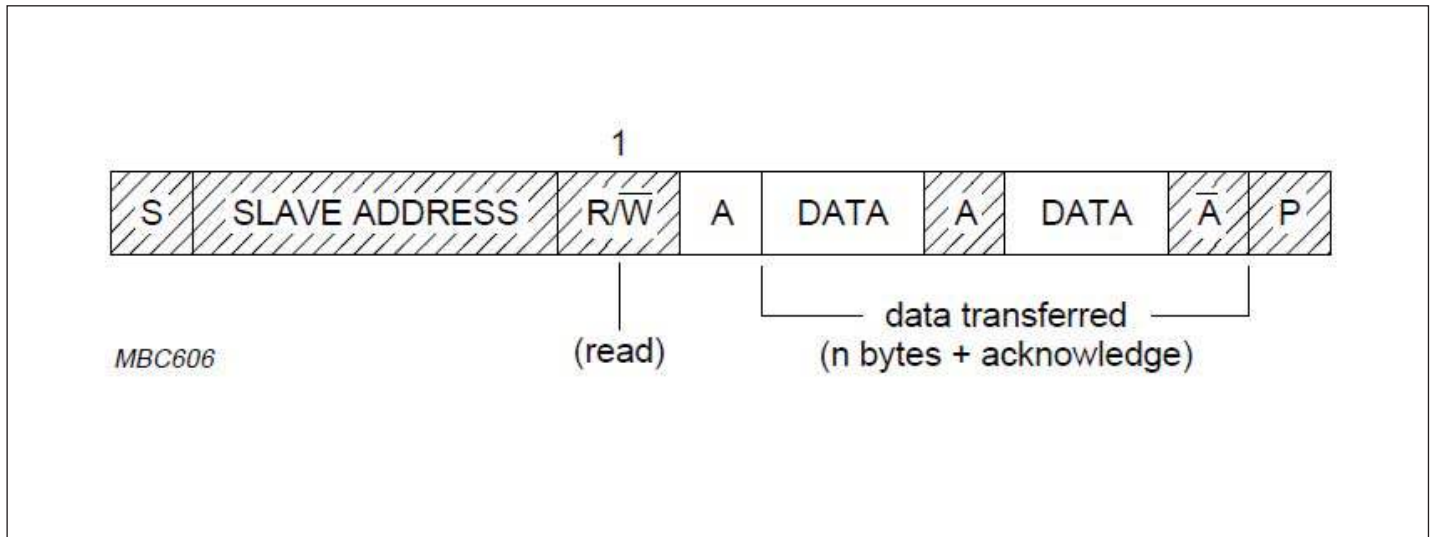
**Figure 1: A Complete Data Transfer**



Data is transmitted to the PI3HDMI2310 registers using the Write mode as shown in Figure 2. Data is read from the PI3HDMI2310 registers using the Read mode as shown in Figure 3.

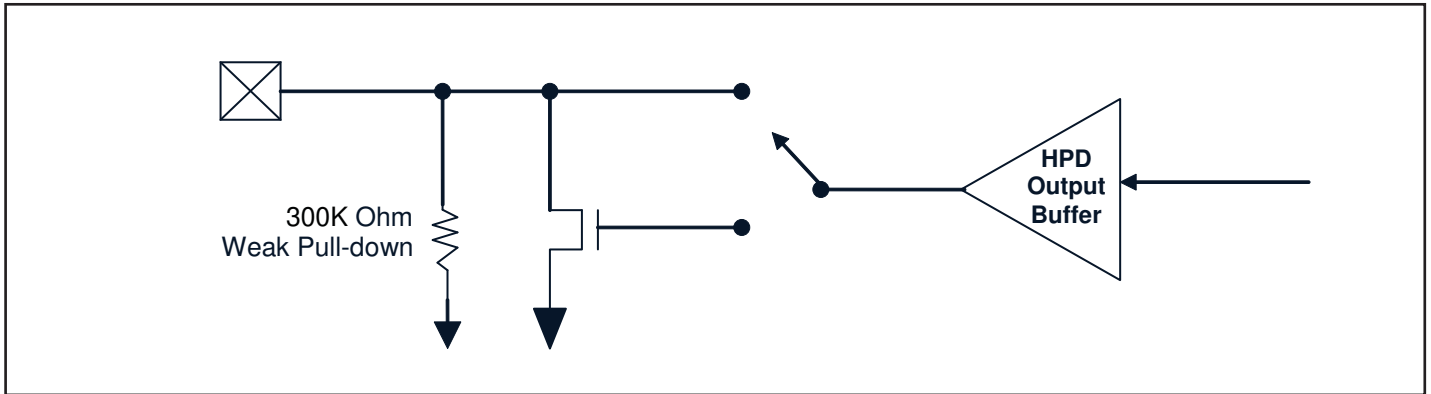


**Figure 2 : Write to Control Register**



**Figure 2 : Read to Control Register**

**HPD Output Buffer**



**Data Channel Pull-down Resistor Control**

Pull-down resistor active conditions:

1. The Data Channel is unselected
2. Output enable control  $\overline{OE}$  is disable ( $\overline{OE}$ =High) or B1b[6]=Low, pull down on all channels
3. No normal operation voltage input (but standby voltage SVDD is still On), pull down on all channels

**Output Enable control**

Output Disable can be asserted through external  $\overline{OE}$  pin or through I<sup>2</sup>C.

$\overline{OE}$	OE_I <sup>2</sup> C B1b[6]	Operation
Low	High	Enable
Low	Low	Disable
High	X	Disable

Default value:  $\overline{OE}$  = Low ; Byte 1 b[6] = High

**Absolute Maximum Ratings** (Over operating free-air temperature range)

Item	Rating
Supply Voltage to Ground Potential	5.5V
All Inputs and Outputs	-0.5V to V <sub>DD</sub> +0.5V
Ambient Operating Temperature	-40 to +85°C
Storage Temperature	-65 to +150°C
Junction Temperature	150°C
Soldering Temperature	260°C

Stress beyond those listed under “Absolute Maximum Ratings” may cause permanent damage to the device.

**Recommended Operation Conditions**

Parameter	Min.	Typ.	Max.	Unit
Ambient Operating Temperature	-40		+85	°C
Power Supply Voltage (measured in respect to GND)	+3.0		+3.6	V

**DC Specifications**

V<sub>DD</sub> = 3.3V ±10%, Ambient Temperature 0 to +70°C

Symbol	Parameter	Conditions	Min	Nom	Max	Units
V <sub>DD</sub>	Operating Voltage		3.0	3.3	3.6	V
I <sub>DD</sub>	Supply Current	Output Enable		5	6	mA
I <sub>DDQ</sub>	Quiescent Supply Current	Output Disable		1.7	2	
V <sub>OH_DDC</sub>	DDC passive switch Output High Voltage	Test condition as I <sub>O</sub> = 0 (open load), V <sub>I</sub> = 5.5V	S <sub>V</sub> DD-1.0			V
V <sub>OL_DDC</sub>	DDC Buffer Output Low Voltage	Source side, I <sub>OL</sub> = 3mA			0.4	
		Sink side, I <sub>OL</sub> = 3mA External pull-up to 3.3V from 1.5kΩ to 4.7kΩ	0.65	0.75	0.95	
V <sub>IH_DDC</sub>	DDC Buffer Input High Voltage	Source side (VSEL = 0)		1.7		
		Sink side (VSEL = 0)		0.5		

Symbol	Parameter	Conditions	Min	Nom	Max	Units
V <sub>IL_DDC</sub>	DDC Buffer Input Low Voltage	Source side			0.8	V
		Sink side (VSEL = 0)	0.45	0.5	0.6	
V <sub>IH_V5_A</sub> , V <sub>IH_V5_B</sub> , V <sub>IH_V5_C</sub>	Input High Voltage of 5V ports		2.4			
V <sub>IL_V5_A</sub> , V <sub>IL_V5_B</sub> , V <sub>IL_V5_C</sub>	Input Low Voltage of 5V ports				0.8	
V <sub>OL_HPD</sub>	Buffer Output Low Voltage	I <sub>OL</sub> = 4 mA			0.4	
	Open Drain Output Low Voltage	I <sub>OL</sub> = 4 mA	0		0.4	
V <sub>OH_HPD</sub>	Buffer Output High Voltage	I <sub>OH</sub> = 3 mA	2.4			
I <sub>OFF (HPD)</sub>	Off Leakage Current	V <sub>DD</sub> = 0V, V <sub>IN</sub> = 3.6V		12	20	μA
		V <sub>DD</sub> = 0V, V <sub>IN</sub> = 5.5V		20	35	
I <sub>OZ_HPD</sub>	Open Drain Output Leakage Current	V <sub>DD</sub> = 3.6V, V <sub>IN</sub> = 3.6V		12	15	
		V <sub>DD</sub> = 3.6V, V <sub>IN</sub> = 5.5V		21	38	
V <sub>OL_DDC_WP</sub>	Open Drain Output Low Voltage	I <sub>OL</sub> = 4 mA			0.4	V
C <sub>IO</sub> <sup>1</sup>	Input/output capacitance (Passive Switch)	V <sub>DD</sub> = 0V or 3.0V, Frequency = 100kHz		6	9	pF

**Note:**

1. Measured at V<sub>bias</sub> = 0V or 5V, V<sub>rms</sub> = 0.2V;

V<sub>bias</sub> = 1.65V, V<sub>rms</sub> = 0.84V;

V<sub>bias</sub> = 2.5V, V<sub>rms</sub> = 1.2V.

### Dynamic Specifications

$V_{DD} = 3.3V \pm 10\%$ ,  $T_A = -40$  to  $+85^\circ C$ ,  $GND = 0V$

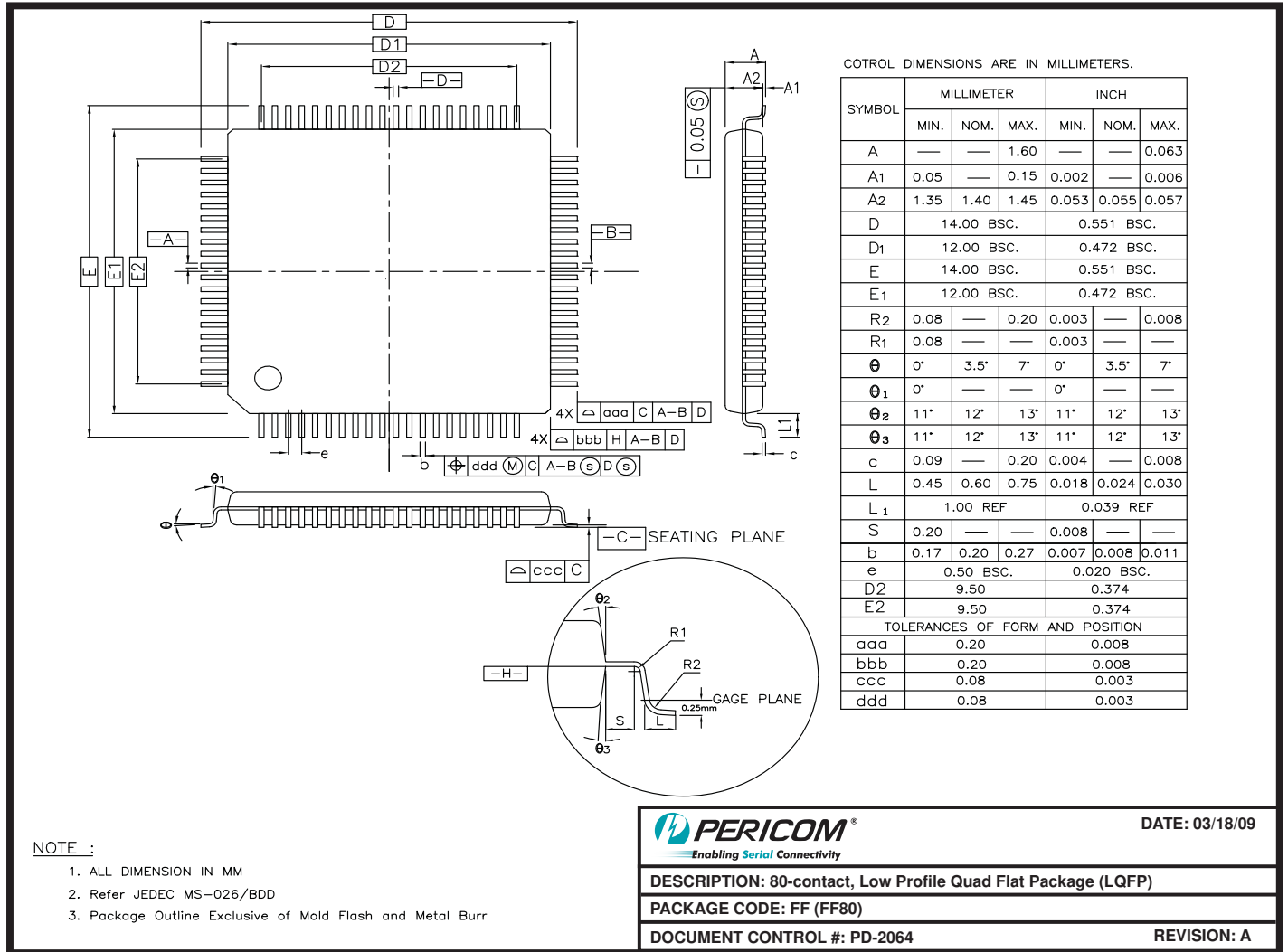
Parameter	Description	Conditions	Min	Typ	Max	Units
X <sub>TALK</sub>	Crosstalk on High-speed Channels	f = 1.13 GHz		-34		dB
		f = 825 MHz		-36		
O <sub>IRR</sub>	OFF Isolation on High-speed Channels	f = 1.13 GHz		-28		dB
		f = 825 MHz		-32		
I <sub>LOSS</sub>	Defferential Insertion Loss on High-speed Channels	DR = 1.65Gbps		-1.5		dB
		DR = 2.0Gbps		-1.73		
		DR = 2.25Gbps		-1.82		
		DR = 3.0Gbps		-1.99		
		DR = 3.4Gbps		-2.08		
BW	-3dB BW for TMDS channels			2.5		GHz

### Capacitance Measurement ( $V_{DD} = 3.3V$ , $T_A = 25^\circ C$ )

Test Condition	Capacitance	Units
SDA_CTL	3.0	pF
SCL_CTL	2.3	
HPD_Sink	1.7	

V<sub>bias</sub>=0.6V

**Packaging Mechanical: 80-Contact LQFP (FF)**



07-0100

For latest package info, please check: <http://www.pericom.com/products/packaging/mechanicals.php>

**Ordering Information**

Ordering Code	Package Code	Package Type
PI3HDMI2310FFE	FF	Pb-free & Green, 80-Contact, LQFP

1. Thermal characteristics can be found on the company web site at [www.pericom.com/packaging/](http://www.pericom.com/packaging/)
2. E = Pb-free and Green
3. Adding an X suffix = Tape/Reel