

# HDMI Switch ICs

**BU16006KV, BU16018KV, BU16024KV, BU16027KV**

No.10063EET01

## ●Description

These devices control are simple. It requires only 3.3V source and a few GPIO controls.

Termination resistors (50Ω) are integrated at all TMDS input port. When channel is not selected, TMDS input termination resistors are turned off and TMDS inputs are high impedance. These devices are also integrated equalizer circuit to adapt long cable and DDC active buffer function to isolate capacitance.

## ●Features

- 1) Supports 2.25 Gbps signaling rate for 480i/p, 720p, and 1080i/p resolution to 12-bit color depth
- 2) Compatible with HDMI 1.3a
- 3) 5V tolerance to all DDC and HPD\_SINK inputs
- 4) Integrated active DDC buffer
- 5) Integrated switchable 50Ω termination resistors
- 6) Integrated equalizer circuit to adapt long cable
- 7) HBM ESD protection exceeds 10kV
- 8) 3.3V fixed supply
- 9) RoHS compatible

## ●Applications

Digital TV, Audio Video Receiver, Digital Projector, DVI or HDMI Switch Box

## ●Line up matrix

Part No.	Power Supply (V)	ESD (KV)	Input and Output	Data rate (Gbps)	Hot Plug Control	Termination Resistor switch Control	Switching Method	DDC Buffer type	Equalizer	High speed mode	Package	RoHS
BU16018KV	3 to 3.6	10	3 input 1 output	2.25	Yes	Sync HPD	GPIO	Active	Fixed	Yes	VQFP80	Yes
BU16027KV	3 to 3.6	10	3 input 1 output	2.25	Yes	Sync S1/S2	GPIO	Active	Fixed	Yes (Always ON)	VQFP64	Yes
BU16006KV	3 to 3.6	10	2 input 1 output	2.25	Yes	Sync HPD	GPIO	Active	Fixed	Yes (Always ON)	VQFP64	Yes
BU16024KV	3 to 3.6	10	1 input 1 output	2.25	Yes	Sync HPD	-	Active	Fixed	Yes	VQFP48C	Yes

## ●Other Line up

HDMI Switch adapted "Repeater" and "Source" Equipment

Part No.	Power Supply (V)	ESD (KV)	Input and Output	Data rate (Gbps)	Hot Plug Control	Termination Resistor switch Control	Switching Method	DDC Buffer type	Equalizer	High speed mode	Package	RoHS
BU16025MUV	3 to 3.6	10	1 input 1 output	2.70	Yes	Sync OE	-	Active	Selectable	Yes	VQFN48AV7070	Yes

● Absolute Maximum Rating

Over operating free-air temperature range (unless otherwise noted)

Item	Limits				Unit
	BU16006KV	BU16018KV	BU16024KV	BU16027KV	
Power supply voltage(Vcc)	-0.3~+4.5	-0.3~+4.5	-0.3~+4.5	-0.3~+4.5	V
DDC, HPD_SINK input voltage	-0.3~+5.6	-0.3~+5.6	-0.3~+5.6	-0.3~+5.6	V
Differential input voltage	+2.5~+4.0	+2.5~+4.0	+2.5~+4.0	+2.5~+4.0	V
Control pin input voltage	-0.3~+4.0	-0.3~+4.0	-0.3~+4.0	-0.3~+4.0	V
Power dissipation	1000(*1)	1200(*2)	950(*3)	1000(*1)	mW
Storage temperature range	-55~+125	-55~+125	-55~+125	-55~+125	°C

(\*1-3) 70mm×70mm×1.6mm glass epoxy board mount. (Reverse Cu occupation rate: 15mm×15mm)

(\*1) When it's used by than Ta=25°C, it's reduced by 10.0mW/°C.

(\*2) When it's used by than Ta=25°C, it's reduced by 12.5mW/°C.

(\*3) When it's used by than Ta=25°C, it's reduced by 9.5mW/°C.

● Recommended Operating Conditions

Symbol	Parameter	Min.	Typ.	Max.	Unit
V <sub>CC</sub>	Supply voltage	3	3.3	3.6	V
T <sub>A</sub>	Free-air temperature	0	-	70	°C
<b>TMDS Differential Pins</b>					
V <sub>IC</sub>	Input common mode voltage, see Figure 2.	V <sub>CC</sub> -0.6	-	V <sub>CC</sub> +0.01	V
V <sub>ID(pp)</sub>	Receiver peak-to-peak differential input voltage, see Figure 2.	150	-	1560	mVp-p
R <sub>VSADJ</sub>	Resistor for TMDS compliant voltage swing range	4.60	4.64	4.68	kΩ
AV <sub>CC</sub>	TMDS Output termination voltage, see Figure 1.	3	3.3	3.6	V
R <sub>T</sub>	Termination resistance, see Figure 1.	45	50	55	Ω
Signaling rate		-	-	2.25	Gbps
<b>Control Pins</b>					
V <sub>IH</sub>	LVTTL High-level input voltage	2	-	V <sub>CC</sub>	V
V <sub>IL</sub>	LVTTL Low-level input voltage	GND	-	0.8	V
<b>HPD_SINK</b>					
V <sub>IH</sub>	High-level input voltage	2.4	-	5.5	V
V <sub>IL</sub>	Low-level input voltage	GND	-	0.8	V
<b>RX (SDA[n],SCL[n])</b>					
V <sub>IH</sub>	High-level input voltage	2.4	-	5.5	V
V <sub>IL</sub>	Low-level input voltage	GND	-	0.8	V
<b>TX (SCL_SINK, SDA_SINK)</b>					
V <sub>IH</sub>	High-level input voltage	1.5	-	5.5	V
V <sub>IL</sub>	Low-level input voltage	GND	-	0.35	V

## ●Electrical Specifications

Over recommended operating conditions (unless otherwise noted)

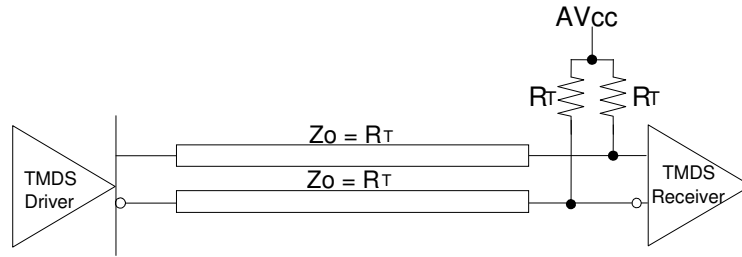
Symbol	Parameter		Test Condition	Limit			Unit
				Min.	Typ. <sup>(1)</sup>	Max.	
I <sub>CC</sub>	Supply current	BU16006KV, BU16018KV BU16027KV	V <sub>ID</sub> = 400mV, R <sub>VSADJ</sub> = 4.64kΩ R <sub>T</sub> = 50Ω, AV <sub>CC</sub> = V <sub>CC</sub> , Am/Bm = 2.25 Gbps HDMI data pattern, A1./B1 = 225 MHz clock See Figure 2	-	120	150	mA
		BU16024KV		-	140	170	mA
P <sub>D</sub>	Power Consumption	BU16006KV, BU16018KV BU16027KV	V <sub>ID</sub> = 400mV, R <sub>VSADJ</sub> = 4.64kΩ R <sub>T</sub> = 50Ω, AV <sub>CC</sub> = V <sub>CC</sub> , Am/Bm = 2.25 Gbps HDMI data pattern, A1./B1 = 225 MHz clock See Figure 2	-	450	600	mW
		BU16024KV		-	480	700	mW
<b>TMDS Differential Pins (A/B;Y/Z)</b>							
V <sub>OH</sub>	Single-ended high-level output voltage	BU16006KV, BU16027KV	AV <sub>CC</sub> = V <sub>CC</sub> , R <sub>T</sub> = 50Ω	AV <sub>CC</sub> - 200	-	AV <sub>CC</sub> - 50	mV
		BU16018KV, BU16024KV	AV <sub>CC</sub> = V <sub>CC</sub> , PRE = V <sub>CC</sub> , R <sub>T</sub> = 50Ω	AV <sub>CC</sub> - 200	-	AV <sub>CC</sub> - 50	mV
		BU16018KV, BU16024KV	AV <sub>CC</sub> = V <sub>CC</sub> , PRE = 0.0V, R <sub>T</sub> = 50Ω	AV <sub>CC</sub> - 10	-	AV <sub>CC</sub> +10	mV
V <sub>OL</sub>	Single-ended low-level output voltage		AV <sub>CC</sub> = V <sub>CC</sub> , R <sub>T</sub> = 50Ω	AV <sub>CC</sub> - 600	-	AV <sub>CC</sub> - 400	mV
V <sub>SWING</sub>	Single-ended low-level swing voltage	BU16006KV, BU16027KV	AV <sub>CC</sub> = V <sub>CC</sub> , R <sub>T</sub> = 50Ω, See Figure 2,	300	-	460	mV
		BU16018KV, BU16024KV	AV <sub>CC</sub> = V <sub>CC</sub> , PRE = V <sub>CC</sub> , R <sub>T</sub> = 50Ω, See Figure 2,	300	-	460	mV
		BU16018KV, BU16024KV	AV <sub>CC</sub> = V <sub>CC</sub> , PRE = 0.0V, R <sub>T</sub> = 50Ω, See Figure 2,	400	-	600	mV
V <sub>od(O)</sub>	Overshoot of output differential voltage		See Figure 2	-	6%	15%	2xV <sub>swing</sub>
V <sub>od(U)</sub>	Undershoot of output differential voltage		See Figure 2	-	12%	25%	2xV <sub>swing</sub>
R <sub>INT</sub>	Input termination resistance		AV <sub>CC</sub> = V <sub>CC</sub> = 3.3V, V <sub>A</sub> = V <sub>B</sub> = V <sub>CC</sub> -400mV, See Figure 2	45	50	55	Ω

Symbol	Parameter	Test Conditions	Limits			Unit		
			Min.	Typ. <sup>(1)</sup>	Max.			
<b>DDC Input and output</b>								
<b>Tx</b>								
I <sub>IKT1</sub>	Input leak current	V <sub>I</sub> =5.5V	-10	-	10	μA		
I <sub>IKT2</sub>	Input leak current	V <sub>I</sub> =V <sub>CC</sub>	-10	-	10	μA		
I <sub>OHT</sub>	High-level output current	V <sub>O</sub> =3.6V	-10	-	10	μA		
I <sub>ILT</sub>	Low-level input current	V <sub>I</sub> =GND	-10	-	10	μA		
V <sub>OLT</sub>	Low-level output voltage	BU16006KV BU16018KV BU16027KV	RL=4.7kΩ	0.43	0.5	0.57	V	
		BU16024KV	RL=4.7kΩ	SELREF = NC	0.43	-	0.57	V
				SELREF = GND	0.58	-	0.72	
				SELREF = V <sub>CC</sub>	0.73	-	0.87	
V <sub>OLT-V<sub>IL</sub></sub>	Low-level input voltage below output low-level voltage	BU16006KV BU16018KV BU16027KV	RL=4.7kΩ	20	100	190	mV	
		BU16024KV	RL=4.7kΩ	SELREF = NC	-	100	-	mV
				SELREF = GND	-	250	-	
				SELREF = V <sub>CC</sub>	-	400	-	
<b>Rx</b>								
I <sub>IKR1</sub>	Input leak current	V <sub>I</sub> =5.5V	-10	-	10	μA		
I <sub>IKR2</sub>	Input leak current	V <sub>I</sub> =V <sub>CC</sub>	-10	-	10	μA		
I <sub>OHR</sub>	High-level output current	V <sub>O</sub> =3.6V	-10	-	10	μA		
I <sub>ILR</sub>	Low-level input current	V <sub>I</sub> =GND	-10	-	10	μA		
V <sub>OLR</sub>	Low-level output voltage	I <sub>out</sub> = 4mA	-	-	0.2	V		
<b>HPD 1, HPD 2, HPD 3</b>								
V <sub>OH(TTL)</sub>	High level output voltage	I <sub>OH</sub> = -8mA	2.4	-	V <sub>CC</sub>	V		
V <sub>OL(TTL)</sub>	Low level output voltage	I <sub>OL</sub> = 8mA	0	-	0.4	V		
<b>CONTROL PINS</b>								
I <sub>IH</sub>	High level input current	V <sub>IH</sub> = V <sub>CC</sub>	-10	-	10	μA		
I <sub>IL</sub>	Low level input current	V <sub>IL</sub> = GND	-10	-	10	μA		
<b>CONTROL PINS (I<sup>2</sup>CEN, SELREF,)</b>								
I <sub>IH</sub>	High level input current	V <sub>IH</sub> = V <sub>CC</sub>	-45	-	45	μA		
I <sub>IL</sub>	Low level input current	V <sub>IL</sub> = GND	-45	-	45	μA		
<b>HPD_SINK</b>								
I <sub>IH</sub>	High level input current	V <sub>IH</sub> = 5.5V	10	50	100	μA		
		V <sub>IH</sub> = V <sub>CC</sub>	5	30	80	μA		
I <sub>IL</sub>	Low -level input current	V <sub>IL</sub> = GND	-10	-	10	μA		

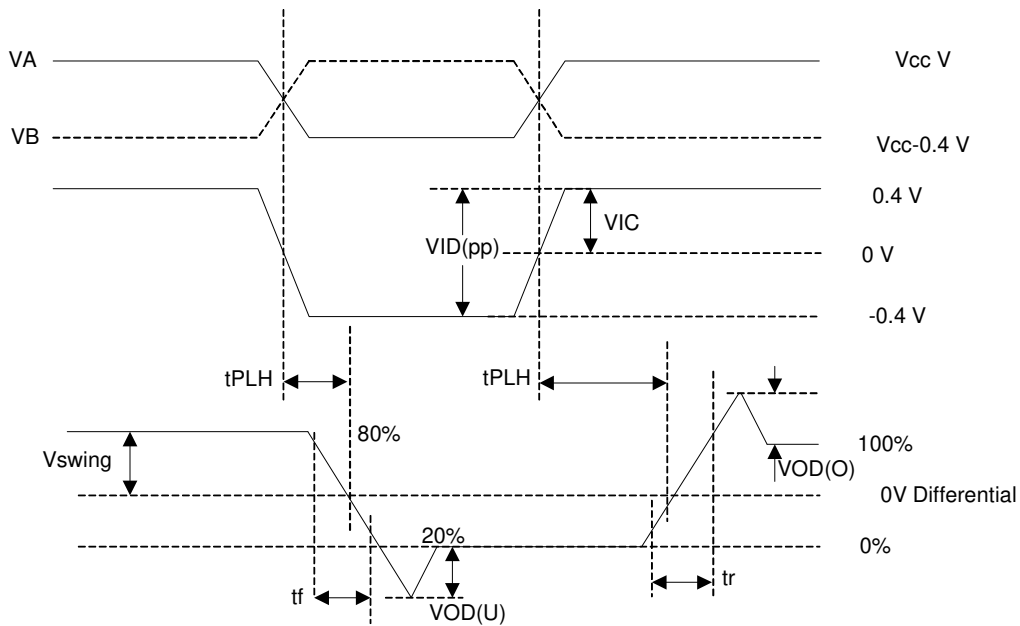
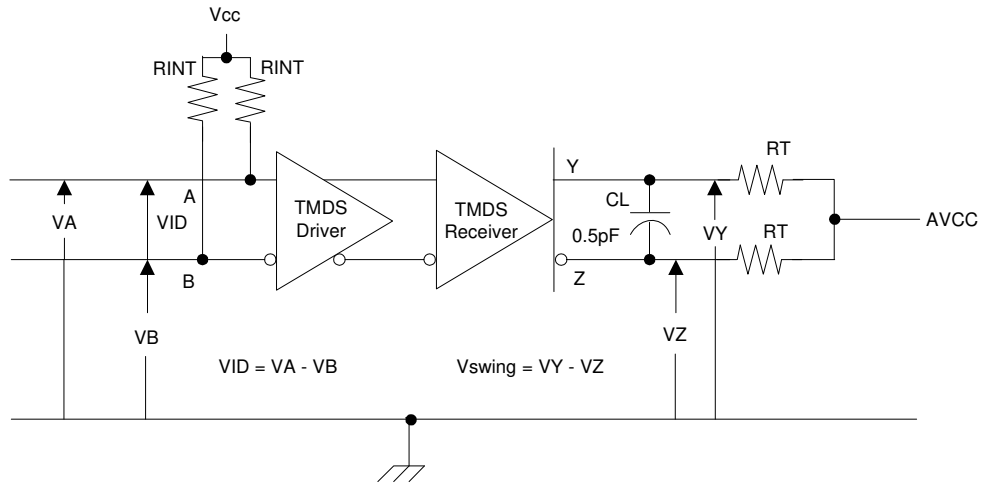
Symbol	Parameter	Test Condition	Limits			Unit
			Min.	Typ. <sup>(1)</sup>	Max.	
TMDS Differential Pins (Y/Z)						
t <sub>PLH</sub>	Propagation delay time low to high level output	BU16006KV, BU16018KV, BU16027KV	-	480	-	ps
		BU16024KV	-	320	-	
t <sub>PHL</sub>	Propagation delay time low to high level output	BU16006KV, BU16018KV, BU16027KV	-	500	-	ps
		BU16024KV	-	335	-	
t <sub>r</sub>	Differential output signal rise time (20%-80%)	BU16006KV, BU16027KV, BU16018KV	-	160	-	ps
		BU16024KV	-	120	-	
t <sub>f</sub>	Differential output signal fall time (20%-80%)	BU16006KV, BU16018KV, BU16027KV	-	160	-	ps
		BU16024KV	-	120	-	
t <sub>sk(p)</sub>	Pulse skew ( t <sub>PHL</sub> - t <sub>PLH</sub>  )	BU16006KV, BU16018KV, BU16027KV	-	20	-	ps
		BU16024KV	-	15	-	
t <sub>sk(D)</sub>	Intra-pair differential skew, see Figure 3.	BU16006KV, BU16018KV, BU16027KV	-	35	-	ps
		BU16024KV	-	25	-	
DDC I/O Pins (SCL, SCL_SINK, SDA, SDA_SINK) See Figure 4						
t <sub>pdLHTR(DDC)</sub>	Propagation delay time, low to high level output Tx to Rx	R <sub>L</sub> = 4.7kΩ, C <sub>L</sub> = 100pF, see Figure 5	-	650	-	ns
t <sub>pdHLTR(DDC)</sub>	Propagation delay time, high to low level output Tx to Rx		-	200	-	ns
t <sub>pdLHRT(DDC)</sub>	Propagation delay time, low to high level output Rx to Tx	R <sub>L</sub> = 1.67kΩ, C <sub>L</sub> = 400pF, see Figure 5	-	500	-	ns
t <sub>pdHLRT(DDC)</sub>	Propagation delay time, high to low level output Rx to Tx		-	350	-	ns
t <sub>r TX(DDC)</sub>	Tx output Rise time	R <sub>L</sub> = 4.7kΩ, C <sub>L</sub> = 100pF, see Figure 5	-	800	-	ns
t <sub>f TX(DDC)</sub>	Tx output Fall time		-	150	-	ns
t <sub>r RX(DDC)</sub>	Rx output Rise time	R <sub>L</sub> = 1.67kΩ, C <sub>L</sub> = 400pF	-	950	-	ns
t <sub>f RX(DDC)</sub>	Rx output Fall time		-	50	-	ns
t <sub>sx</sub>	Select to switch output	see Figure 4	-	8	-	ns
t <sub>dis</sub>	Disable time	see Figure 4	-	5	-	ns
t <sub>en</sub>	Enable time	see Figure 4	-	7	-	ns
t <sub>sx(DDC)</sub>	Switch time from SCLn to SCL_SINK	C <sub>L</sub> =10pF	-	800	-	ns
C <sub>IO</sub>	Input/output capacitance	V <sub>I</sub> =0V	-	15	-	pF
Hot Plug Detect Pins						
t <sub>pdLH(HPD)</sub>	Propagation delay time, low to high level output from HPD_SINK to HPDn(n=1,2,3)	C <sub>L</sub> =10pF	-	5	-	ns
t <sub>pdHL(HPD)</sub>	Propagation delay time, high to low level output from HPD_SINK to HPDn(n=1,2,3)	C <sub>L</sub> =10pF	-	5	-	ns
t <sub>sx(HPD)</sub>	Switch time from port select to the latest valid status of HPD	C <sub>L</sub> =10pF	-	8	-	ns

Note: (1). All typical values are at 25°C and with a 3.3V supply.

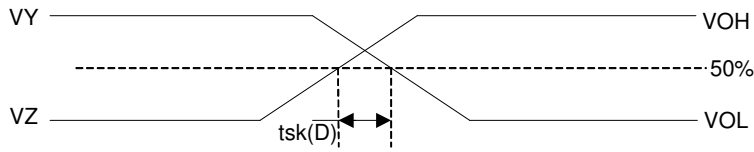
● Measurement Symbol And Circuit



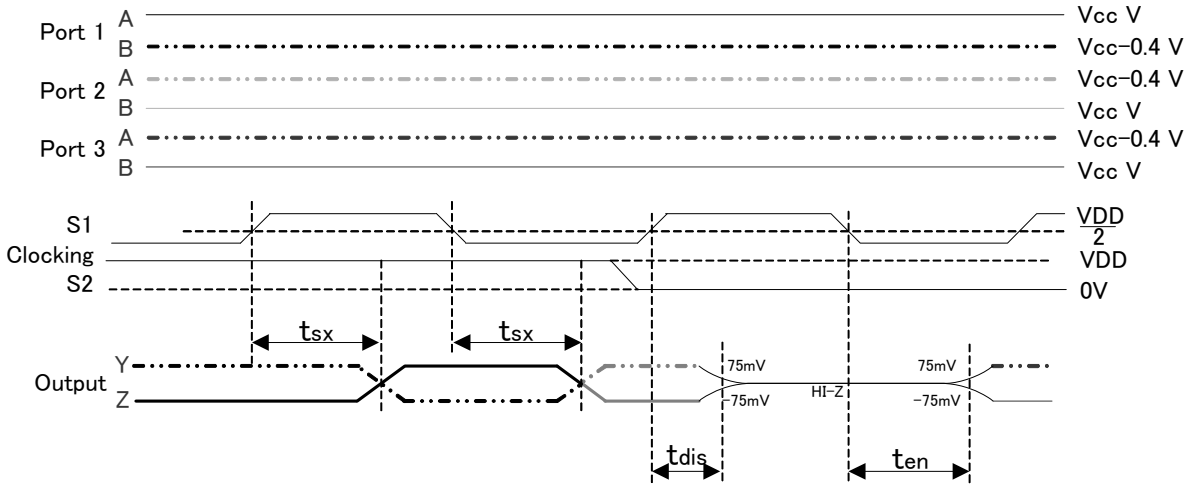
**Figure 1 TMS Output Driver**



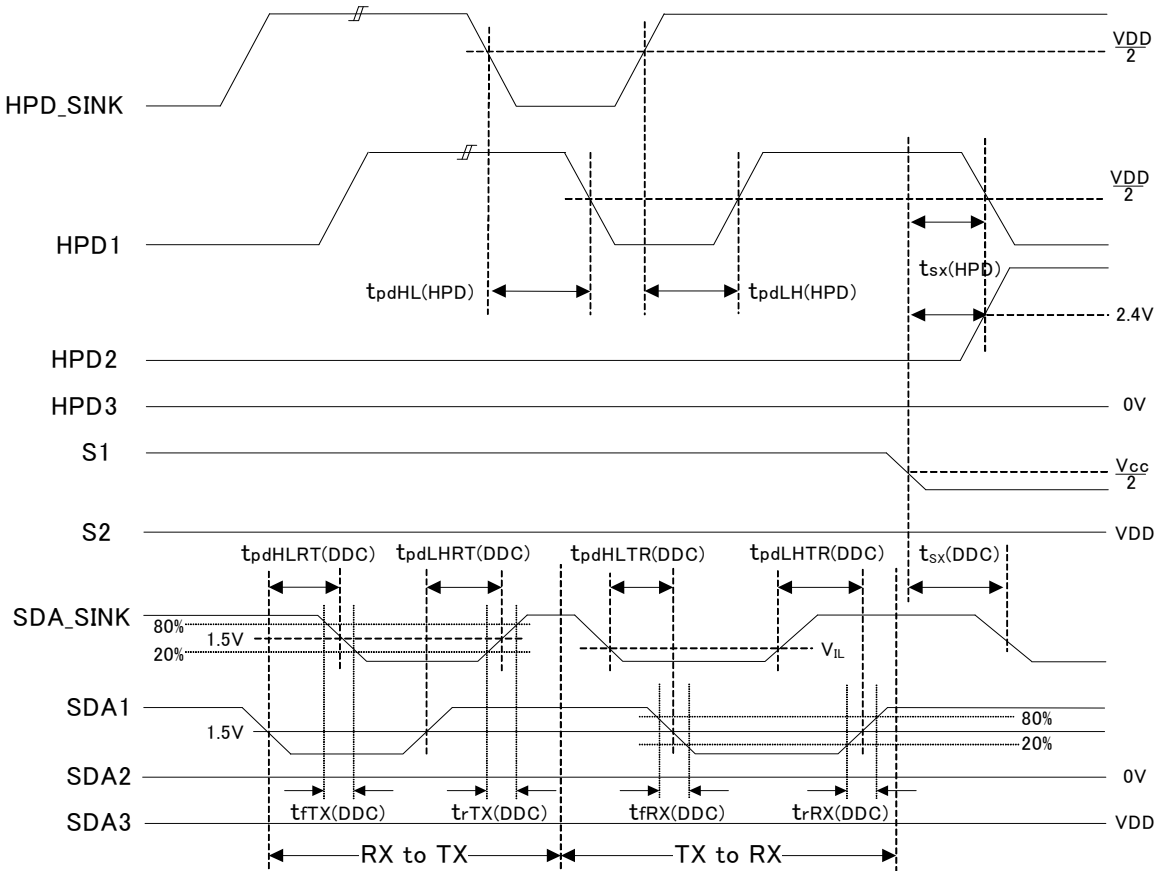
**Figure 2 Test Circuit and Definitions**



**Figure 3 Definition of Intra-Pair Differential Skew**

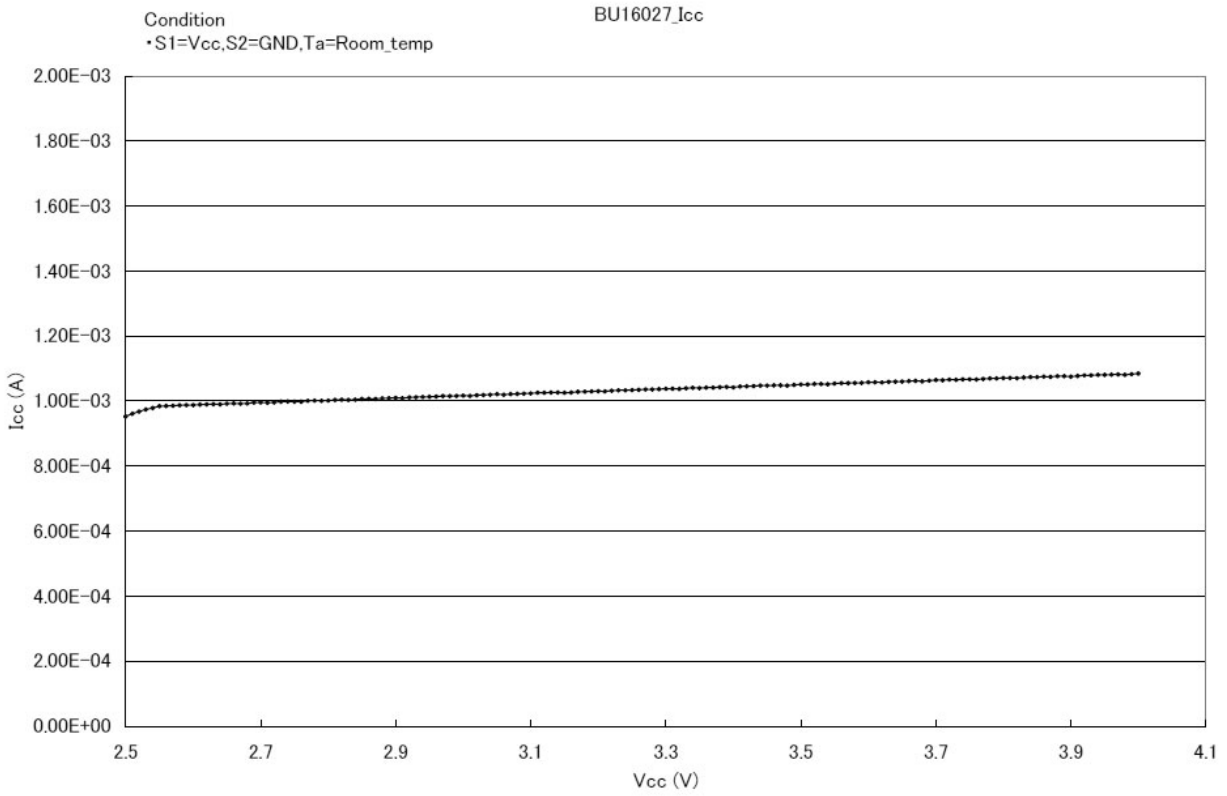


**Figure 4 TMDs Outputs Control Timing Definitions**



**Figure 5 DDC and HPD Timing Definitions**

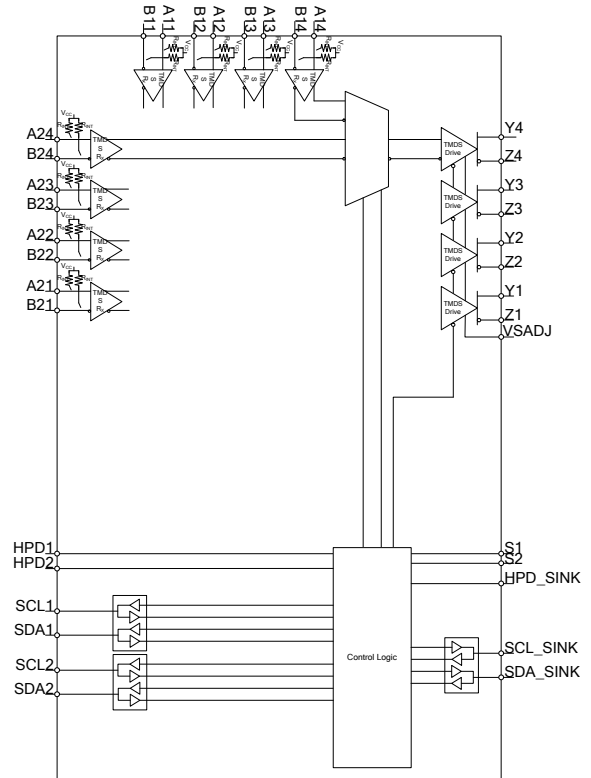
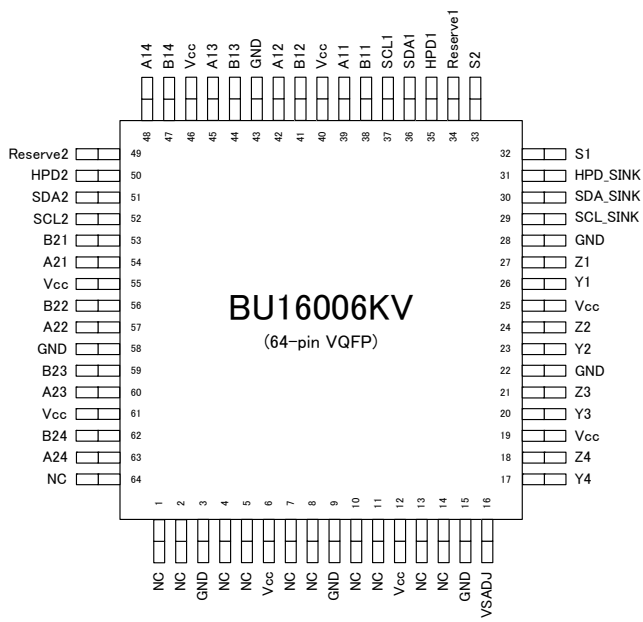
●Reference Data of BU16027KV/BU16006KV



**Figure 6 Supply voltage(Vcc) vs. Supply current(Icc) of BU16006KV/BU16027KV [S1=H,S2=L]**



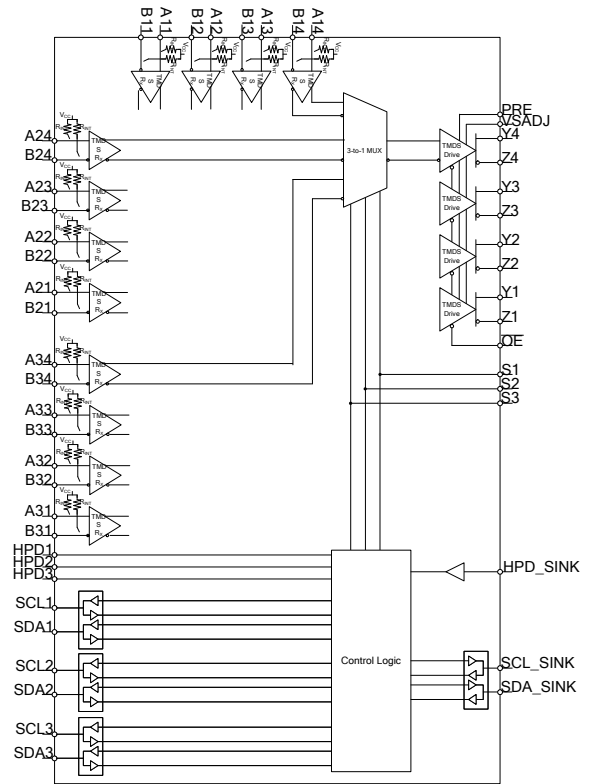
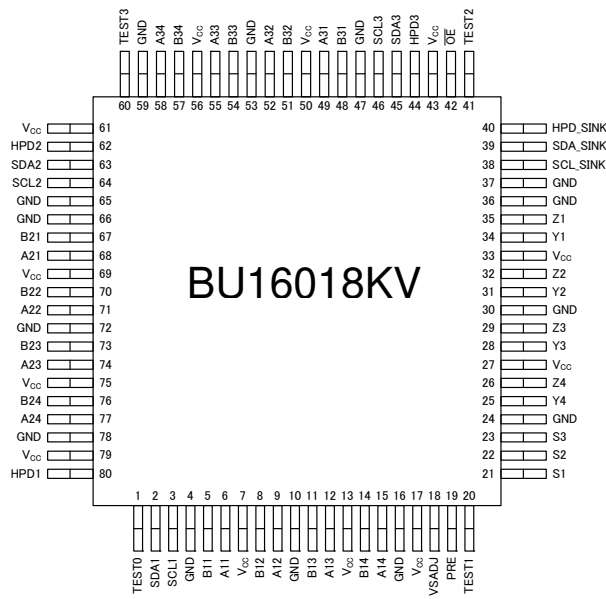
● Pin Assignment and Block Diagram of BU16006KV



● Pin Explanation List

Terminal		I/O	Description
Name	No.		
A11, A12, A13, A14	39, 42, 45, 48	I	Source port 1 TMDS positive inputs
A21, A22, A23, A24	54, 57, 60, 63	I	Source port 2 TMDS positive inputs
B11, B12, B13, B14	38, 41, 44, 47	I	Source port 1 TMDS negative inputs
B21, B22, B23, B24	53, 56, 59, 62	I	Source port 2 TMDS negative inputs
GND	3, 9, 15, 22, 28, 43, 58	-	Ground
HPD1	35	O	Source port 1 hot plug detector output
HPD2	50	O	Source port 2 hot plug detector output
HPD_SINK	31	I	Sink port hot plug detector input
Reserve1	34	I/O	Set to HIGH/LOW/OPEN
Reserve2	49	I/O	Non Connect Pin
SCL1	37	I/O	Source port 1 DDC I <sup>2</sup> C clock line
SCL2	52	I/O	Source port 2 DDC I <sup>2</sup> C clock line
SCL_SINK	29	I/O	Sink port DDC I <sup>2</sup> C clock line
SDA1	36	I/O	Source port 1 DDC I <sup>2</sup> C data line
SDA2	51	I/O	Source port 2 DDC I <sup>2</sup> C data line
SDA_SINK	30	I/O	Sink port DDC I <sup>2</sup> C data line
S1, S2	32, 33	I	Source selector
Vcc	6, 12, 19, 25, 40, 46, 55, 61	-	Power supply
VSADJ	16	I	TMDS compliant voltage swing control (4.64kΩ to GND)
Y1, Y2, Y3, Y4	26, 23, 20, 17	O	TMDS positive outputs
Z1, Z2, Z3, Z4	27, 24, 21, 18	O	TMDS negative outputs

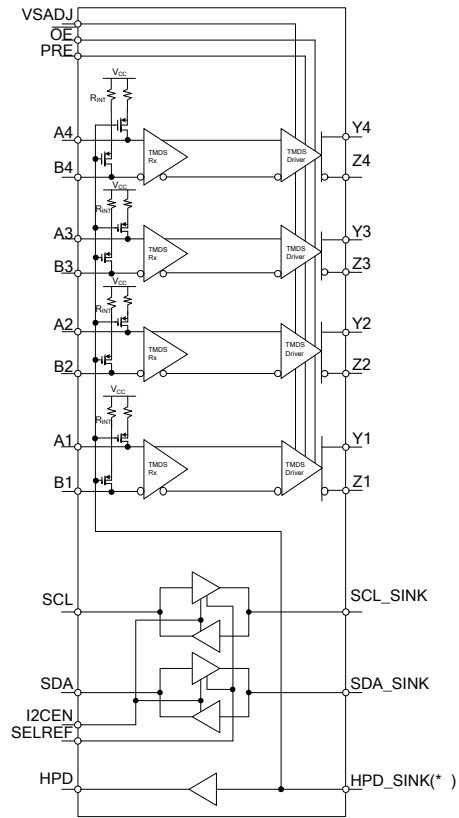
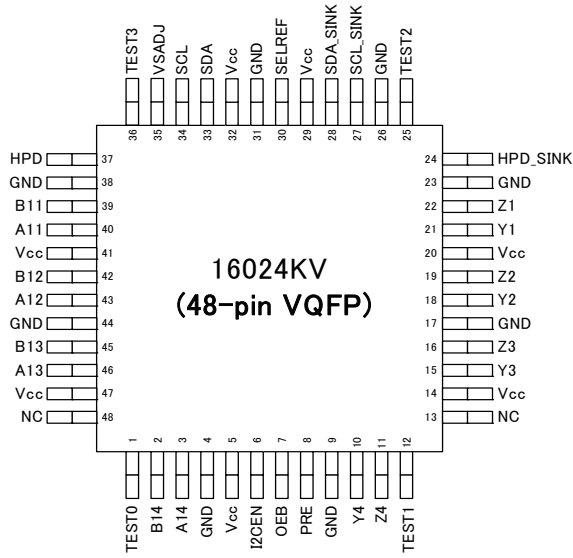
● Pin Assignment and Block Diagram of BU16018KV



● Pin Explanation List

Terminal		I/O	Description
Name	No.		
A11, A12, A13, A14	6, 9, 12, 15	I	Port 1 TMDs positive inputs
A21, A22, A23, A24	68, 71, 74, 77	I	Port 2 TMDs positive inputs
A31, A32, A33, A34	49, 52, 55, 58	I	Port 3 TMDs positive inputs
B11, B12, B13, B14	5, 8, 11, 14	I	Port 1 TMDs negative inputs
B21, B22, B23, B24	67, 70, 73, 76	I	Port 2 TMDs negative inputs
B31, B32, B33, B34	48, 51, 54, 57	I	Port 3 TMDs negative inputs
GND	4, 10, 16, 24, 30, 36, 37, 47, 53, 59, 65, 66, 72, 78	-	Ground
HPD1	80	O	Port 1 hot plug detector output
HPD2	62	O	Port 2 hot plug detector output
HPD3	44	O	Port 3 hot plug detector output
HPD_SINK	40	I	Sink side hot plug detector input
TEST0,1,2,3	1, 20, 41, 60		Open or GND connect (recommnd)
OE	42	I	Output enable, active low
PRE	19	I	TMDs high speed mode SW High : ON, Low : OFF (above 165MHz recommend to High)
SCL1	3	I/O	Source port 1 DDC I <sup>2</sup> C clock line
SCL2	64	I/O	Source port 2 DDC I <sup>2</sup> C clock line
SCL3	46	I/O	Source port 3 DDC I <sup>2</sup> C clock line
SCL_SINK	38	I/O	Sink port DDC I <sup>2</sup> C clock line
SDA1	2	I/O	Source port 1 DDC I <sup>2</sup> C data line
SDA2	63	I/O	Source port 2 DDC I <sup>2</sup> C data line
SDA3	45	I/O	Source port 3 DDC I <sup>2</sup> C data line
SDA_SINK	39	I/O	Sink port DDC I <sup>2</sup> C data line
S1, S2, S3	21, 22, 23	I	Source selector input
Vcc	7, 13, 17, 27, 33, 43, 50, 56, 61, 69, 75, 79	-	Power supply
VSADJ	18	I	TMDs voltage swing control. Connect to GND 4.64KΩ
Y1, Y2, Y3, Y4	34, 31, 28, 25	O	TMDs positive outputs
Z1, Z2, Z3, Z4	35, 32, 29, 26	O	TMDs negative outputs

● Pin Assignment and Block Diagram of BU16024KV

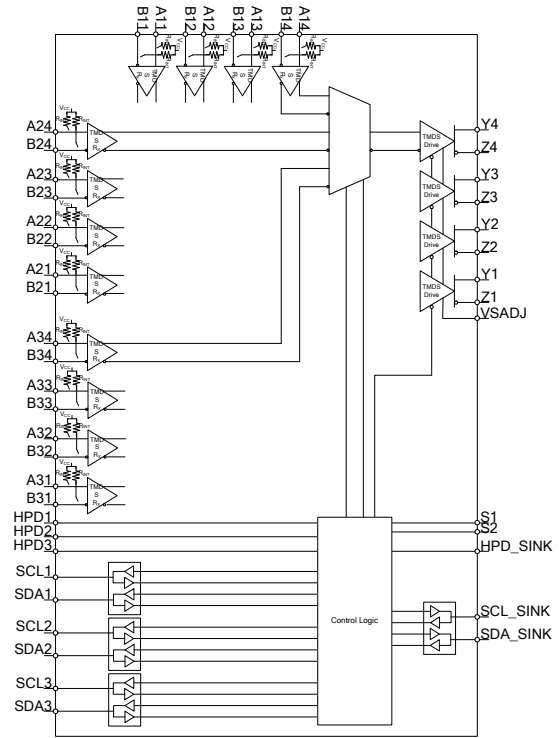
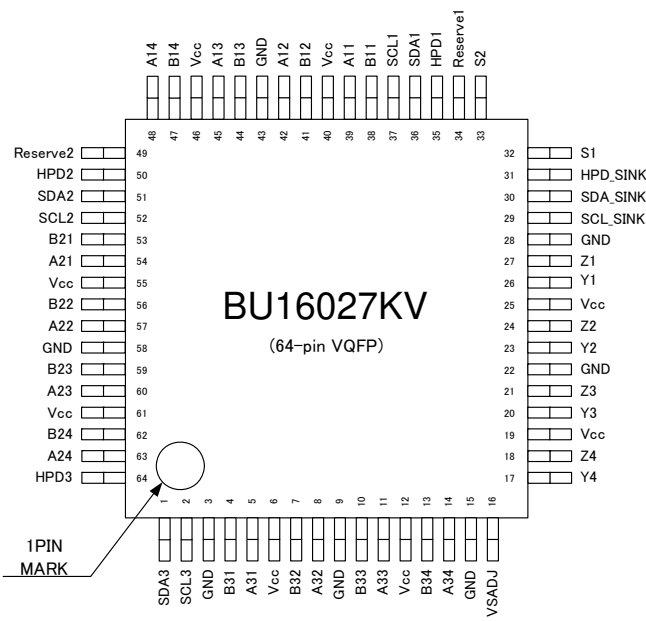


(\*) when HPD\_SINK = "L". Termination resistor is turned off.

● Pin Explanation List

Terminal		I/O	Description
Name	No.		
B1, B2, B3, B4	39, 42, 45, 2	I	TMDS Negative inputs
A1, A2, A3, A4	40, 43, 46, 3	I	TMDS Positive inputs
Z1, Z2, Z3, Z4	22, 19, 16, 11	O	TMDS Negative outputs
Y1, Y2, Y3, Y4	21, 18, 15, 10	O	TMDS Positive outputs
HPD	37	O	Source side hot plug detector output
HPD_SINK	24	I	Sink side hot plug detector input
SCL	34	I/O	Source port DDC I <sup>2</sup> C clock line
SDA	33	I/O	Source port DDC I <sup>2</sup> C data line
SCL_SINK	27	I/O	Sink port DDC I <sup>2</sup> C clock line
SDA_SINK	28	I/O	Sink port DDC I <sup>2</sup> C data line
VSADJ	35	I	TMDS voltage swing control(4.64kΩ to GND)
I <sup>2</sup> CEN	6	I	I <sup>2</sup> C Repeater enable Low : High-Z High : Active
SELREF	30	I	SCL_SINK/SDA_SINK Output voltage select
TEST0, 1, 2, 3	1, 12, 25, 36	I	Open or GND connect (recommend)
N.C	13, 48		Open or GND connect (recommend)
OEB	7	I	TMDS Output enable Low : Active High : High-Z
PRE	8	I	TMDS high speed mode SW High : ON, Low : OFF (above 165MHz recommend to High)
V <sub>CC</sub>	5, 14, 20, 29, 32, 41, 47	-	Power supply
GND	4, 9, 17, 23, 26, 31, 38, 44	-	Ground

● Pin Assignment and Block Diagram of BU16027KV



● Pin Explanation List

Terminal		I/O	Description
Name	No.		
A11, A12, A13, A14	39, 42, 45, 48	I	Source port 1 TMDs positive inputs
A21, A22, A23, A24	54, 57, 60, 63	I	Source port 2 TMDs positive inputs
A31, A32, A33, A34	5, 8, 11, 14	I	Source port 3 TMDs positive inputs
B11, B12, B13, B14	38, 41, 44, 47	I	Source port 1 TMDs negative inputs
B21, B22, B23, B24	53, 56, 59, 62	I	Source port 2 TMDs negative inputs
B31, B32, B33, B34	4, 7, 10, 13	I	Source port 3 TMDs negative inputs
GND	3, 9, 15, 22, 28, 43, 58	-	Ground
HPD1	35	O	Source port 1 hot plug detector output (status pin)
HPD2	50	O	Source port 2 hot plug detector output (status pin)
HPD3	64	O	Source port 3 hot plug detector output (status pin)
HPD_SINK	31	I	Sink port hot plug detector input (status pin)
Reserve1	34	I/O	In High, Low, and Open, any setting is OK.
Reserve2	49	I/O	Non Connect Pin
SCL1	37	I/O	Source port 1 DDC I <sup>2</sup> C clock line
SCL2	52	I/O	Source port 2 DDC I <sup>2</sup> C clock line
SCL3	2	I/O	Source port 3 DDC I <sup>2</sup> C clock line
SCL_SINK	29	I/O	Sink port DDC I <sup>2</sup> C clock line
SDA1	36	I/O	Source port 1 DDC I <sup>2</sup> C data line
SDA2	51	I/O	Source port 2 DDC I <sup>2</sup> C data line
SDA3	1	I/O	Source port 3 DDC I <sup>2</sup> C data line
SDA_SINK	30	I/O	Sink port DDC I <sup>2</sup> C data line
S1, S2	32, 33	I	Source selector
Vcc	6, 12, 19, 25, 40, 46, 55, 61	-	Power supply
VSADJ	16	I	TMDs voltage swing control (via 4.64kΩ to GND)
Y1, Y2, Y3, Y4	26, 23, 20, 17	O	Sink port TMDs positive outputs
Z1, Z2, Z3, Z4	27, 24, 21, 18	O	Sink port TMDs negative outputs

●Source Selection Lookup Table of BU16006KV

Control Pins			I/O Selected	Output Status			
HPD_SINK	S1	S2	Y/Z	SCL_SINK SDA_SINK	HPD1	HPD2	HPD3
H	H	H	A1/B1 Termination resistors of A2/B2 and A3/B3 are disconnected	SCL1 SDA1	H	L	L
H	L	H	A2/B2 Termination resistors of A1/B1 and A3/B3 are disconnected	SCL2 SDA2	L	H	L
H	L	L	Disallowed (indeterminate) State All termination resistors are disconnected	None (Z)	L	L	H
H	H	L	None (Z) All termination resistors are disconnected		H	H	H
L	H	H	Disallowed (indeterminate) State All termination resistors are disconnected	SCL1 SDA1	L	L	L
L	L	H	Disallowed (indeterminate) State All termination resistors are disconnected	SCL2 SDA2	L	L	L
L	L	L	Disallowed (indeterminate)State All termination resistors are disconnected	None (Z)	L	L	L
L	H	L	None (Z) All termination resistors are disconnected		L	L	L

●Source Selection Lookup Table of BU16027KV

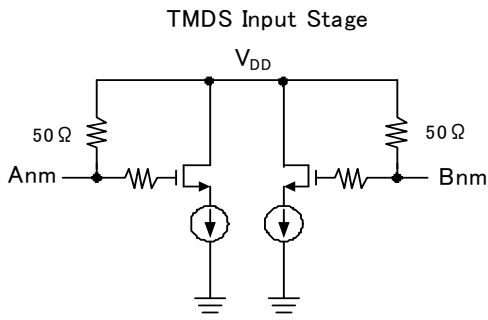
Control Pins			I/O Selected	Output Status			
HPD_SINK	S1	S2	Y/Z	SCL_SINK SDA_SINK	HPD1	HPD2	HPD3
H/L	H	H	A1/B1 Termination resistors of A2/B2 and A3/B3 are disconnected	SCL1 SDA1	HPD_SINK	L	L
H/L	L	H	A2/B2 Termination resistors of A1/B1 and A3/B3 are disconnected	SCL2 SDA2	L	HPD_SINK	L
H/L	L	L	A3/B3 Termination resistors A1/B1 and A2/B2 are disconnected	SCL3 SDA3	L	L	HPD_SINK
H/L	H	L	None (Z) All terminations are disconnected	None (Z)	HPD_SINK	HPD_SINK	HPD_SINK

●Source Selection Lookup Table of BU16018KV

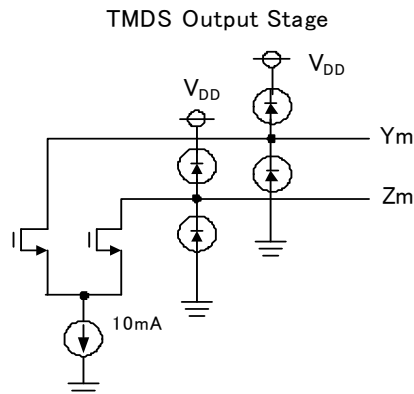
Control Pins				I/O Selected	Output Status			
HPD_SINK	S1	S2	S3	Y/Z	SCL_SINK/SDA_SINK	HPD1	HPD2	HPD3
H	H	X	X	A1/B1 Termination resistors of A2/B2 and A3/B3 are disconnected	SCL1 SDA1	H	L	L
H	L	H	X	A2/B2 Termination resistors of A1/B1 and A3/B3 are disconnected	SCL2 SDA2	L	H	L
H	L	L	H	A3/B3 Termination resistors of A1/B1 and A2/B2 are disconnected	SCL3 SDA3	L	L	H
H	L	L	L	None (Z) All terminations are disconnected	None (Z)	H	H	H
L	H	X	X	Disallowed (indeterminate)State All terminations are disconnected	SCL1 SDA1	L	L	L
L	L	H	X	Disallowed (indeterminate)State All terminations are disconnected	SCL2 SDA2	L	L	L
L	L	L	H	Disallowed (indeterminate)State All terminations are disconnected	SCL3 SDA3	L	L	L
L	L	L	L	None (Z) All terminations are disconnected	None (Z)	L	L	L

H: Logic high; L: Logic low; X: Don't care; Z: High impedance

●Equivalent Input And Output Schematic Diagrams

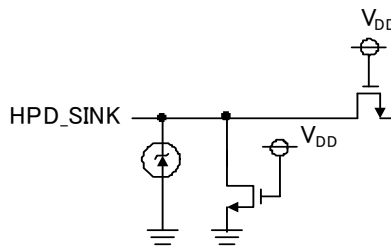
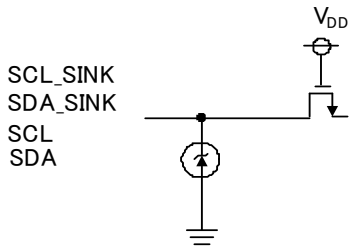
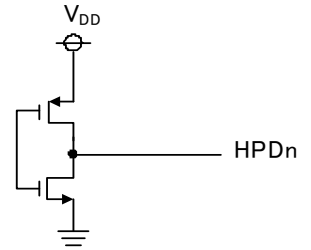


R-Side I<sup>2</sup>C Input/Output Stage



T-Side I<sup>2</sup>C Input/Output Stage

HPD Output Stage

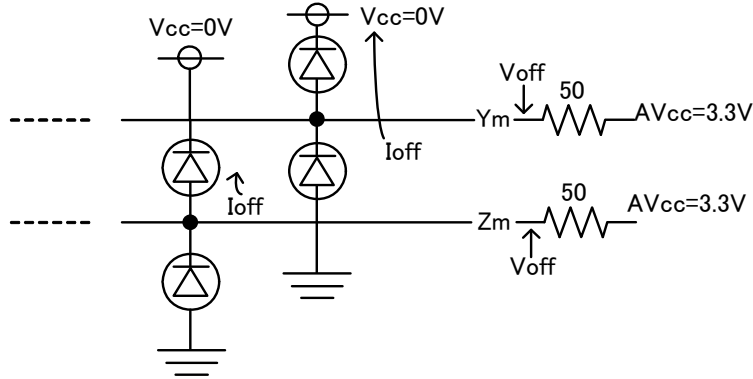


※n=1,2,3 m=1,2,3,4

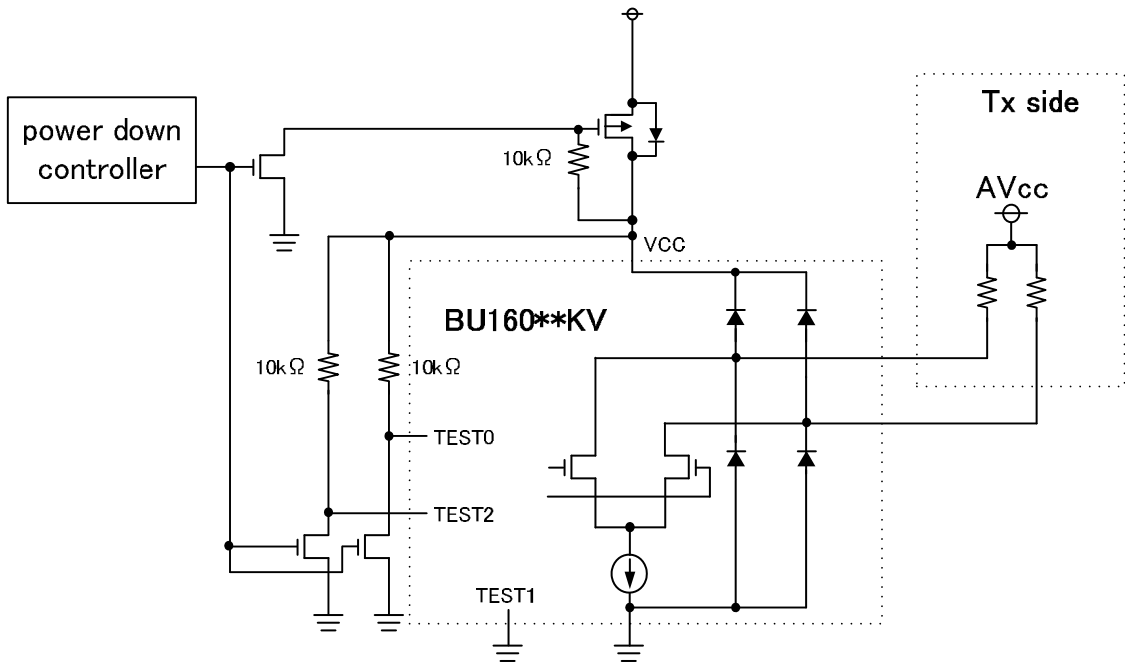
●Note for use

1). Attention on use as “repeater” or “source” equipment.

Y and Z terminals are connected to Vcc through ESD diode as Figure 7. When  $V_{cc} + 0.4 < AV_{cc}$ , leak current flows from AVcc to Vcc. For this current, BU16006KV/BU16027KV can't pass the compliance test as “Repeater” and “Source” equipment (Test ID 7-3 VOFF). BU16018KV/BU16024KV is able to pass the compliance test using external element like Figure 8



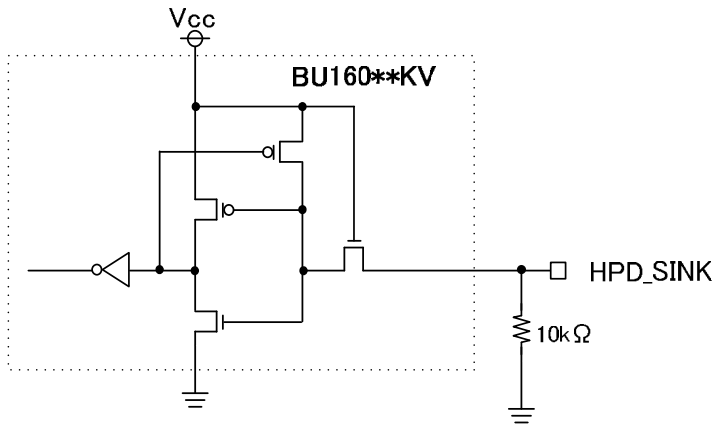
**Figure 7 TMDs Equivalent output schematic**



**Figure 8 Leak current control in BU16018KV and BU16024KV**

2). HPD\_SINK Pull down resistance.

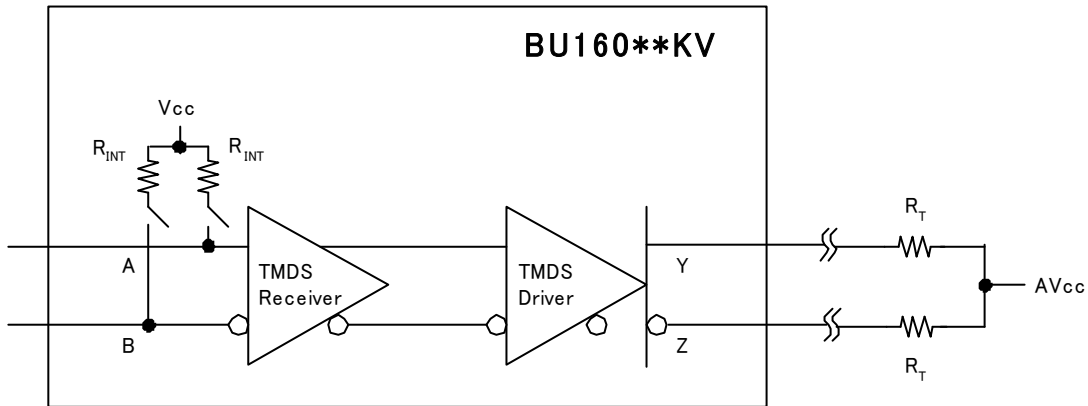
HPD\_SINK have a 5V tolerant structure shown in Figure 9. It needs some drive current to pull down HPD\_SINK "H" to "L". So to pull down HPD\_SINK, please use 10kΩ (or under 10kΩ) resistor.



**Figure 9 HPD\_SINK I/O schematic**

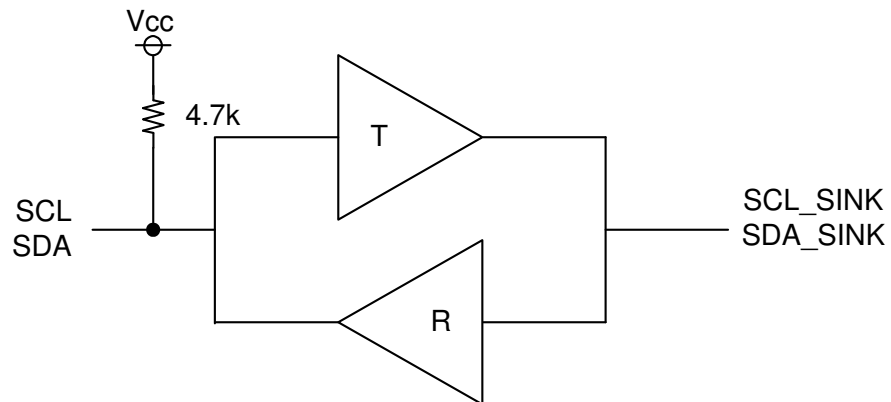
3). About don't use terminal.

3-1. Unused TMDS input channel recommend open.



**Figure 10 TMDS Input Recommendation**

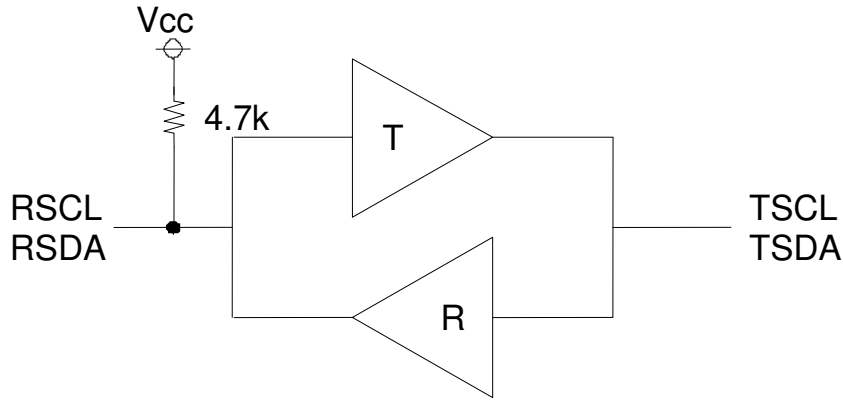
3-2. Unused DDC Buffers of R side recommend to pull up to Vcc.



**Figure 11 Unused DDC Buffers of R side**

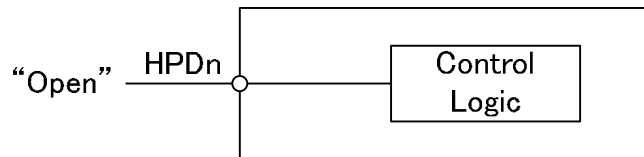


3-3. Unused DDC Buffers of R side recommend pull up to Vcc.



**Figure 12 Unused DDC of T side**

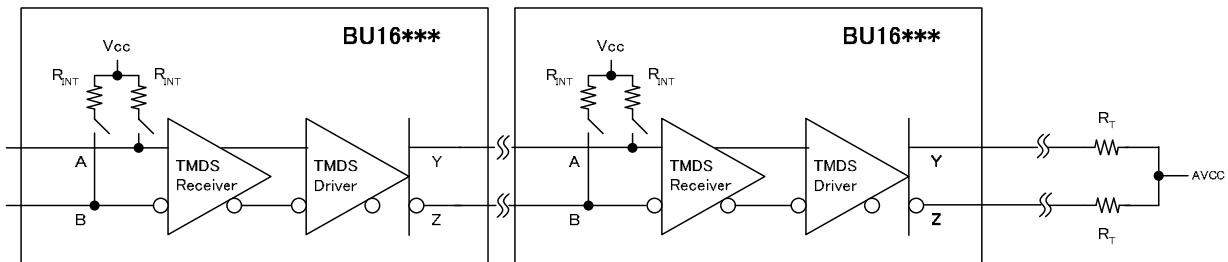
3-4. Unused HPDn recommend open.



**Figure 13 Open unused HPDn**

4). About serial connection notice.

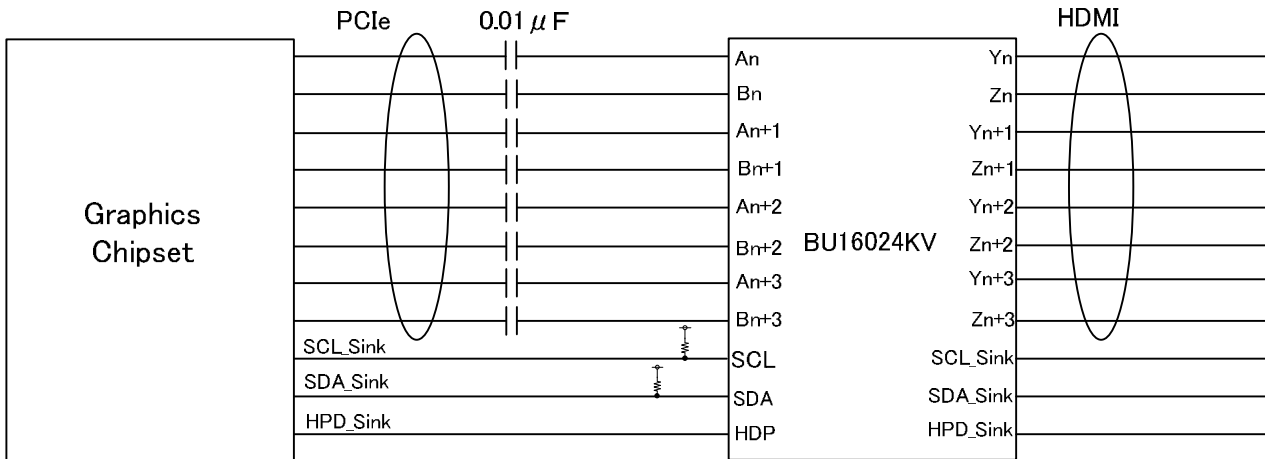
When BU160xxKV output connect to other HDMI sw input like following application the specification of Jitter tolerance is downed. Especially when system needs 1080p (12bit) data rate and cable or PCB trace lengths between BU160xxKV input and output is small, Deteriorations of Jitter tolerance is outstanding. This problem also depends on receiver IC characteristic. When system is required 1080p (12bit), Rohm doesn't recommend serial connect application.



**Figure 14 serial connection notice**

5). AC Coupling notice

BU160xxKV can also communicate using AC coupling capacitor with TMDS line. But even connecting AC coupling capacitor, AC current may flow if input common mode voltage between two devices is different. For this current, the lower common mode voltage devices like PCIe or DP may be damaged by AC current.

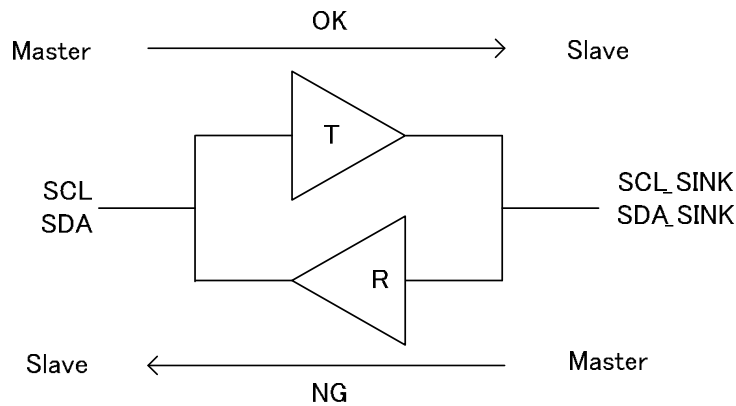


**Figure 15 AC Coupling connection notice**

6). TMDS output offset voltage notice.

Offset voltage may appear to TMDS output when there is no signal to TMDS input differential line. OE should set to “H” to avoid it.

7). Limitation of Master and slave direction as shown Figure 16.



**Figure 16 Limitation of Master and slave direction**

●Ordering part number

B	U
---	---

1	6	0	0	6
---	---	---	---	---

K	V
---	---

-	E	2
---	---	---

Part No.

Part No.

16006  
16018  
16024  
16027

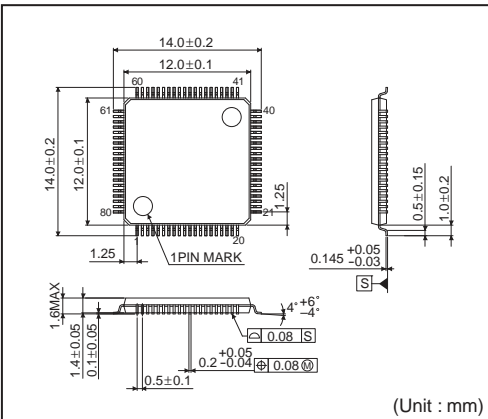
Package

KV: VQFP80  
(BU16018),  
VQFP64  
(BU16027 /  
BU16006),  
VQFP48C  
(BU16024)

Packaging and forming specification

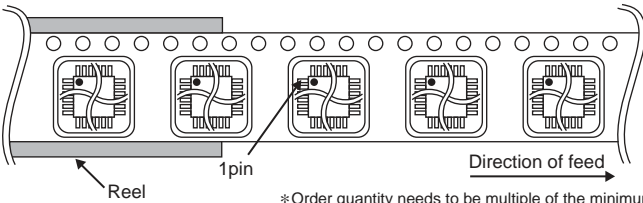
E2: Embossed tape and reel

VQFP80

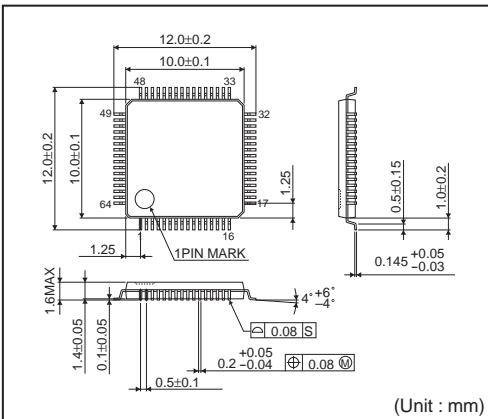


<Tape and Reel information>

Tape	Embossed carrier tape (with dry pack)
Quantity	1000pcs
Direction of feed	E2 ( The direction is the 1pin of product is at the upper left when you hold reel on the left hand and you pull out the tape on the right hand )

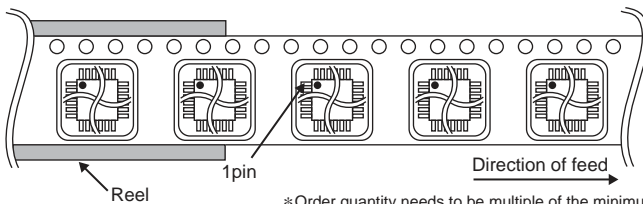


VQFP64

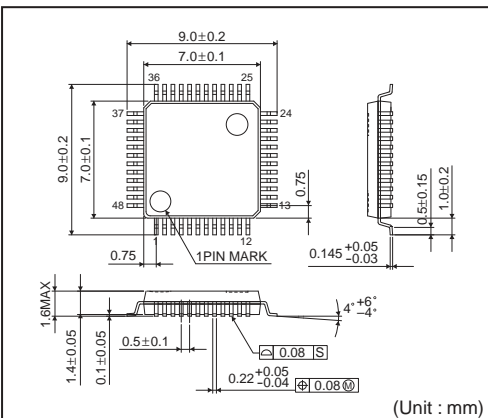


<Tape and Reel information>

Tape	Embossed carrier tape (with dry pack)
Quantity	1000pcs
Direction of feed	E2 ( The direction is the 1pin of product is at the upper left when you hold reel on the left hand and you pull out the tape on the right hand )

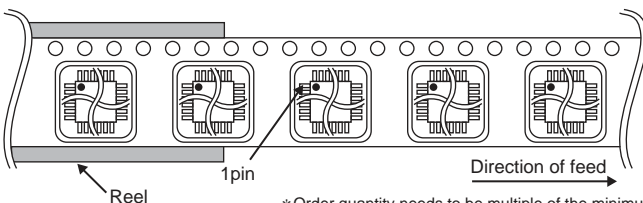


VQFP48C



<Tape and Reel information>

Tape	Embossed carrier tape
Quantity	1500pcs
Direction of feed	E2 ( The direction is the 1pin of product is at the upper left when you hold reel on the left hand and you pull out the tape on the right hand )



## Notes

No copying or reproduction of this document, in part or in whole, is permitted without the consent of ROHM Co.,Ltd.

The content specified herein is subject to change for improvement without notice.

The content specified herein is for the purpose of introducing ROHM's products (hereinafter "Products"). If you wish to use any such Product, please be sure to refer to the specifications, which can be obtained from ROHM upon request.

Examples of application circuits, circuit constants and any other information contained herein illustrate the standard usage and operations of the Products. The peripheral conditions must be taken into account when designing circuits for mass production.

Great care was taken in ensuring the accuracy of the information specified in this document. However, should you incur any damage arising from any inaccuracy or misprint of such information, ROHM shall bear no responsibility for such damage.

The technical information specified herein is intended only to show the typical functions of and examples of application circuits for the Products. ROHM does not grant you, explicitly or implicitly, any license to use or exercise intellectual property or other rights held by ROHM and other parties. ROHM shall bear no responsibility whatsoever for any dispute arising from the use of such technical information.

The Products specified in this document are intended to be used with general-use electronic equipment or devices (such as audio visual equipment, office-automation equipment, communication devices, electronic appliances and amusement devices).

The Products specified in this document are not designed to be radiation tolerant.

While ROHM always makes efforts to enhance the quality and reliability of its Products, a Product may fail or malfunction for a variety of reasons.

Please be sure to implement in your equipment using the Products safety measures to guard against the possibility of physical injury, fire or any other damage caused in the event of the failure of any Product, such as derating, redundancy, fire control and fail-safe designs. ROHM shall bear no responsibility whatsoever for your use of any Product outside of the prescribed scope or not in accordance with the instruction manual.

The Products are not designed or manufactured to be used with any equipment, device or system which requires an extremely high level of reliability the failure or malfunction of which may result in a direct threat to human life or create a risk of human injury (such as a medical instrument, transportation equipment, aerospace machinery, nuclear-reactor controller, fuel-controller or other safety device). ROHM shall bear no responsibility in any way for use of any of the Products for the above special purposes. If a Product is intended to be used for any such special purpose, please contact a ROHM sales representative before purchasing.

If you intend to export or ship overseas any Product or technology specified herein that may be controlled under the Foreign Exchange and the Foreign Trade Law, you will be required to obtain a license or permit under the Law.



Thank you for your accessing to ROHM product informations.  
More detail product informations and catalogs are available, please contact us.

## ROHM Customer Support System

<http://www.rohm.com/contact/>